



**Asia-Pacific
Economic Cooperation**

Overview of the 2017 ESCI Best Practices Awards Program

Singapore, 24 April 2017

APEC Energy Working Group

April 2017

APEC Project: EWG 04 2016S

Produced by
ESCI Management Team
d32375@tier.org.tw

For
Asia-Pacific Economic Cooperation Secretariat
35 Heng Mui Keng Terrace
Singapore 119616
Tel: (65)68919 600
Fax: (65) 68919 690
Email: info@apec.org
Website: www.apec.org

©2017 APEC Secretariat

APEC# 217-RE-04.2

Table of Contents

Executive Summary

Session I: Overview of the 2017 ESCI Best Practices Awards Program

Overview of the 2017 ESCI Best Practices Awards Program

Speaker: Mr Alon Abramson, Project Manager, Penn Institute for Urban Research

Session II: Knowledge Sharing

Smart Transport

- *Gold- “Smart Park ICT Re-engineering Initiative” by Chinese Taipei Speaker: Dr Jason Yi-Bing Lin, Vice Chancellor, University System of Taiwan*

Smart Buildings

- *Gold- “Smart City Shioashiya “Solar-Shima”” by Japan Speaker: Ms Sumiyo Muraoka, Leader, Property Development Business, PanaHome Corporation*
- *Silver- “Energy Conservation Virtue at Huachiew Chalermprakiet University” by Thailand Speaker: Dr Prachak Poomvises, President, Huachiew Chalermprakiet University*

Smart Grids

- *Silver- “Penghu Dongjiyu Microgrid Small Power Supply System” by Chinese Taipei Speaker: Mr Chun-Der Chang, Chung-Hsin Electric & Machinery Mfg. Corporation, Special Assistant*

Smart Jobs and Consumers

- *Gold- “BCA-MOE Back to School Programme” by Singapore Speaker: Mr Sian Ching Ng, Executive Manager, Building and Construction Authority of Singapore*
- *Silver- “Applied Leadership Program for Renewable Energies and Energy Efficiency in Mexico” by Mexico Speaker: Mr Francisco Acuna, Chief Executive Officer, InTrust Global Investments*

Low Carbon Model Towns

- *Gold- “Solar Powered City - Tainan Reaches for the Sun” by Chinese Taipei Speaker: Tainan City Government*

Executive Summary

Launched in 2010 by U.S. President Obama and Japan's former Prime Minister Kan, the Energy Smart Communities Initiative (ESCI) has contributed greatly to the advancement of green growth, sustainable development, long-term job creation and APEC's goal of energy intensity reduction of at least 45 percent by 2035 with 2005 as the reference. As the information hub of ESCI network, the Knowledge Sharing Platform (KSP) has helped disseminate and share best practices of ESCI's areas of focus in a systematic manner.

As a way to encourage best practices, facilitate knowledge-sharing and give public recognition to individual accomplishment in the energy smart related cases within APEC region, ESCI hosts an ESCI Best Practice Award Programs. The first awards occurred in 2013, and the second awards occurred in 2015. In 2017, 7 out of 10 winning teams from 6 economies (including Mexico, Republic of Korea, Singapore, Thailand, Chinese Taipei, and the United States) attended to the 3rd award ceremony and shared their valuable experiences with all energy experts in the region.

Session I

Overview of the 2017 ESCI Best Practices Awards Program

Alon Abramson

5019 Hazel Ave. Phila., PA 19143 M: 267-324-9948 E: alon.abramson@gmail.com

Work Experience

University of Pennsylvania Institute for Urban Research

Project Manager for Energy Initiatives Nov. 2011 – Present

Responsible for all elements of two grant-funded projects: maintaining project schedules and budgets, producing deliverables, progress reporting internally and externally, and preparing proposals for continuing funding. Specific project highlights:

Asia Pacific Economic Cooperation Energy Smart Communities Initiative

- Developed a demo website for the ESCI Knowledge Sharing Platform. Then, managed the production of a professionally-built site based upon the demo. Continue to curate the website for content submitted by users and by internal staff. Website contains over three-hundred best practice cases and over one hundred publications.
- Traveled to six international workshops to promote the project and provide updates to APEC Energy Working Group members.
- Produced two best practices reports – Energy Smart Community Development Policy and Smart Transportation. Presented the former at a conference to a group of APEC planners and policy makers in Taipei, Chinese Taipei in May 2014.

Consortium for Building Energy Innovation (previously known as the Energy Efficient Buildings Hub and the Greater Philadelphia Innovation Cluster)

- Created a web portal for communicating research findings, called the [Research Digest](#). Managed the web development from inception to launch. Website attracted nearly 4,000 visitors per month.
- Produced content for more than fifty research summaries by conducting interviews with researchers, performing literature reviews, and managing a team of three graduate students to write copy.
- Directed the production of five infographics, twelve videos, and two long-format reports to complement the website copy.
- Worked with over a dozen partner organizations, notably in partnership with PJM Interconnection on an electricity public awareness campaign and Science Festival exhibit.

- Maintained funding through three budget periods, despite federal budget cuts to the organization.

Golder Associates, Inc., Conshohocken, PA

Engineering Associate June 2008 - March 2010

Was responsible for a range of projects, including engineering design of mechanical systems, compliance oversight of a power plant construction, environmental property assessments, and on-site environmental sampling.

F. X. Browne, Inc., Lansdale, PA

Staff Engineer July 2006 - September 2007

Worked on civil engineering site designs for commercial buildings and wastewater treatment systems.

Education

Lehigh University Lehigh University

MS Environmental Engineering, May 2006

BS Civil Engineering, May 2005

Other Competencies

Certifications: LEED Green Associate, Green Roofing Professional, Passive House Institute Certified Consultant

Software: ArcGIS, Adobe Design Suite, Microsoft Office Suite. Self-taught in a host of software such as building energy benchmarking tools and many web-based applications, such as LucidPress. Adept at rapidly learning new software and web tools.

Social Media: Wordpress CMS, Mail Chimp, Hoot Suite, and all popular social media platforms.

Publications and Websites

Abramson, A. and Brown, D.G. 2007. "[Influence of solution ionic strength on the collision efficiency distribution and predicted transport distance of a *Sphingomonas* sp. flowing through porous media.](#)", Water Research, 41(19)

Brown, D.G. and Abramson, A. 2006. "[Collision efficiency distribution of a bacterial suspension flowing through porous media and implications for field-scale transport.](#)", Water Research, 40(8)

Abramson, A. 2013. "[Boundless Energy: Equipped with its own grid, the Navy Yard has a unique energy plan.](#)" Grid Magazine.

Consortium for Building Energy Innovation [Web Platform](#).

APEC Energy Smart Communities Initiative [Knowledge Sharing Platform](#).

Volunteer Activities

West Philly Runners, Philadelphia, PA

Group Founder November 2010 – Present

When I moved to West Philadelphia, I discovered a place that encouraged community collaboration and interaction. It felt like a small town more than a city. This was the inspiration for starting the West Philly Runners. The group is founded on the principle that we can strengthen our community by running through it together.

Open Streets PHL, Philadelphia, PA

Co-Chair, October 2015 - Present

I co-chair Open Streets PHL, a non-profit whose primary objective is to provide free and fun recreation to all members of the community by temporarily closing select streets to vehicle traffic while opening them up to endless possibilities of people-powered movement. Our group advocates and advises the City of Philadelphia on best practices for producing and promoting open streets events. In our first year, we were able to successfully petition the city to host its first ever open streets event.

Reference details available upon request.



Knowledge
Sharing
Platform



Overview of the 2017 ESCI Best Practices Awards Program

April 24, 2017
Singapore, EWG53

Dr Eugenie Birch, Co-Director, Penn IUR
Alon Abramson, Project Manager, Penn
IUR



Knowledge
Sharing
Platform

Origin and Purpose of ESCI-KSP

Energy Smart Communities Initiative – Knowledge Sharing Platform (ESCI-KSP)

- Background
 - Concept approved EWG-41, Vancouver (Spring, 2011)
 - Financial support from Chinese Taipei (late summer, 2011)
 - Executed by Taiwan Institute for Economic Research and Penn Institute for Urban Research (Fall and Winter, 2011-2012)
 - Launched EWG 43, Kuala Lumpur (Winter, 2012)
- Purposes
 - Help APEC economies meet energy intensity reduction goals of 45% by 2030 from 2005 levels through exchange of **best practices, research and development of new products, demonstration projects and metrics**
 - Foster the growth of **communities of practice**: networks of individuals with common interests and goals
 - **Provide information to the public** about smart transport, buildings, grids, jobs, and low carbon model towns



Low Carbon Model Towns



Smart Transport



ST-1



ST-2



ST-3



ST-4



Smart Buildings



SB-1



SB-2



SB-3



SB-4



Smart Grids



SG-1



SG-2



Smart Jobs



SJ-1



SJ-2



SJ-3



Industry



I-1



I-2



I-3

2013 EWG46
1st Awards Ceremony

- Cases that have adopted single or multiple policies/technologies are eligible (individual and integrated level)
- Gold, Silver, and Bronze Awards in each level

2015 EWG50
2nd Awards Ceremony

- Based on the ESCI pillar to re-categorize to five pillars (Smart Transport, Smart Buildings, Smart Grids, Smart Jobs and Consumers, Low Carbon Model Towns)
- Gold and Silver Awards in each pillar

2017 EWG53
3rd Awards Ceremony

- Expand the jury members from seven to ten
- Judging considered the cases' articulation and compatibility with their strategies, measures, and outcomes.

Strategy (30%)

Innovativeness (10%)

Inspiration (10%)

Cleanness (10%)

Measure (40%)

Practicability(10%)

Replicability(10%)

Cost-effectiveness (10%)

Consistency(10%)

Performance (30%)

Completeness (10%)

Verifiability (10%)

Impact (10%)

APEC member	Jury	Background
The United States	Dr Eugenie L. Birch (Chair)	FAICP, RTPI (hon), is Lawrence C. Nussdorf Professor of Urban Research, Chair, Graduate Group of City and Regional Planning, University of Pennsylvania School of Design, co-director, Penn Institute for Urban Research (Penn IUR)
Australia	Mr Andrew Scally	Assistant Manager, Strategic Policy and International Section, Gas, Governance and International Branch Energy Division, Department of the Environment and Energy
Hong Kong, China	Prof. Derek S.W. OR	Director, Smart Materials & Systems Laboratory; Electrical Protection & High Voltage Coordination Laboratory, The Hong Kong Polytechnic University
Japan	Mr Shinji ISHII	Director, Natural Resources and Energy Research, Agency for Natural Resources and Energy(ANRE), Ministry of Economy, Trade and Industry(METI)
Korea	Mr Hwang Inchul	Director, International Cooperation Team, Global Strategy Division, Korea Energy Agency
Singapore	Mr Toh Eng Shyan	Director, Green Mark Department (Existing Buildings), Environmental Sustainability Group, Building and Construction Authority (BCA)
Chinese Taipei	Mr Yang Feng-Shou	Director, Research Division V, Taiwan Institute of Economic Research
Thailand	Mr Somkiat Sutiratana	Advisor, New Energy Development, ENSOL Company Limited
APERC	Mr OJIMI Takato	President, The Asia Pacific Energy Research Centre (APERC)
APSEC	Ms Zhu Li	President, APEC Sustainable Energy Center (APSEC)

Pillar	Case	Rank	APEC member
Smart Transport	Smart Park ICT Re-engineering Initiative	GOLD	Chinese Taipei
Smart Transport	California Electromobility Roadmaps	SILVER	The
Smart Buildings	Smart City Shioashiya "Solar-Shima"	GOLD	Japan
Smart Buildings	Energy Conservation Virtue at Huachiew Chalermprakiet University	SILVER	Thailand
Smart Grids	Entergy New Orleans "SmartView" AMI Pilot	GOLD	The United States
Smart Grids	Penghu Dongjiyu Microgrid Small Power Supply System	SILVER	Chinese Taipei
Smart Jobs & Consumers	BCA Back to School Programme: Getting student alumni to be involved in greening of schools	GOLD	Singapore
Smart Jobs & Consumers	Applied Leadership Program for Renewable Energies and Energy Efficiency in Mexico	SILVER	Mexico
Low Carbon Model Towns	Solar Powered City - Tainan Reaches for the Sun	GOLD	Chinese Taipei
Low Carbon Model Towns	Songdo, Korea	SILVER	Republic of Korea

Smart Transport- Gold

Smart Park ICT Re-engineering Initiative

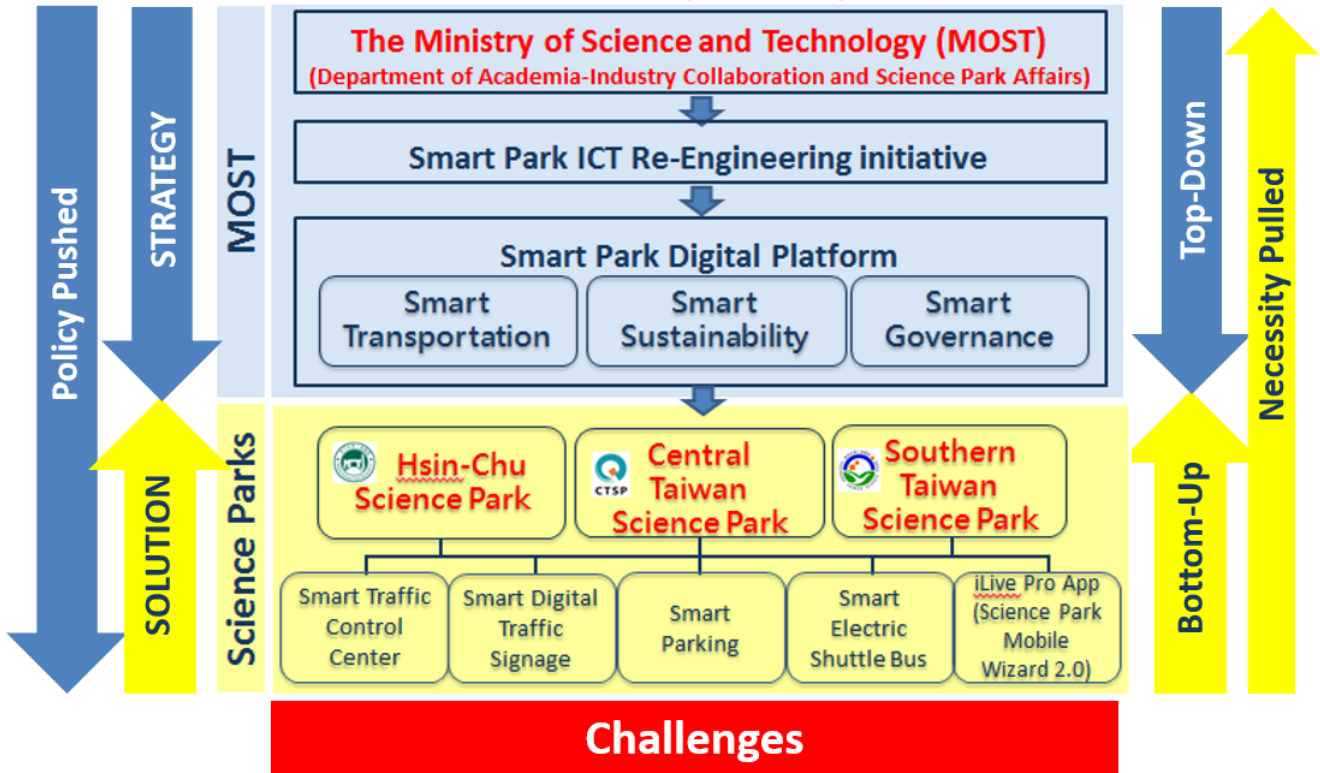

Smart Transport - Silver

California Electromobility Roadmaps

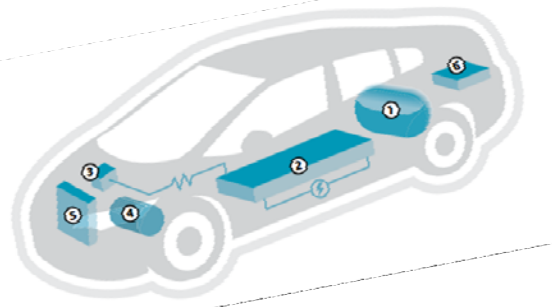

Smart Buildings- Gold

Smart City Shioashiya "Solar-Shima"

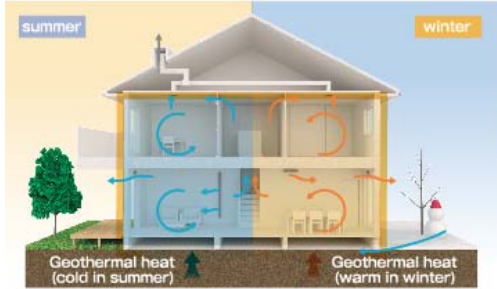

Smart Buildings-Silver

Energy Conservation Virtue at Huachiew Chalermprakiet University

HCU Energy & Environment Map

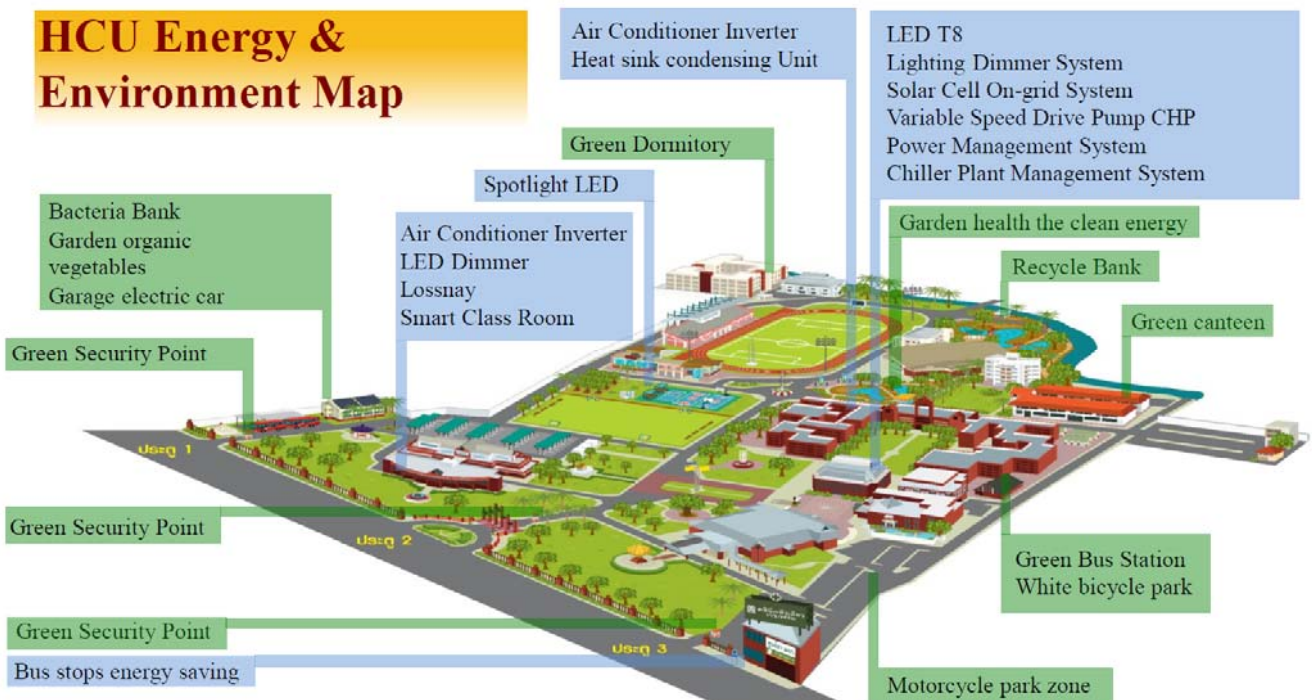

Smart Grids-Gold

Entergy New Orleans "SmartView" AMI Pilot

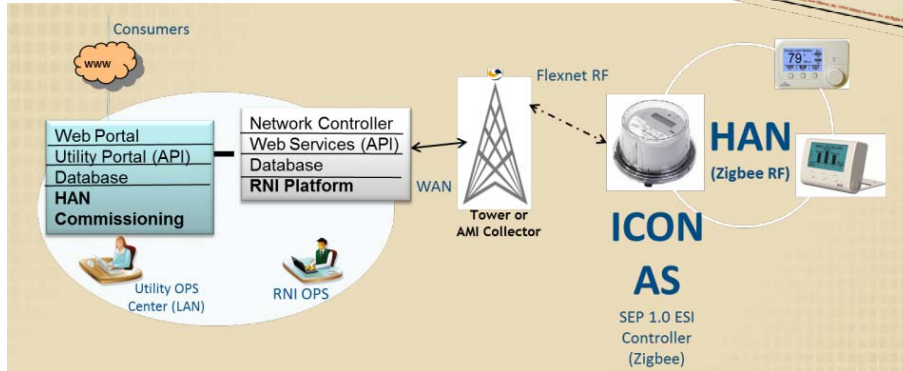

Smart Grids-Silver

Penghu Dongjiyu Microgrid Small Power Supply System

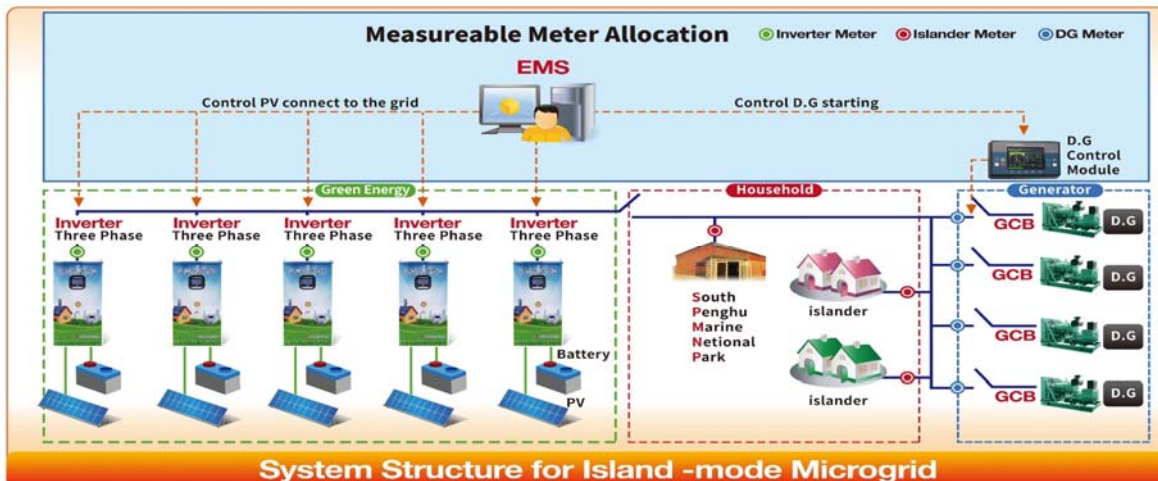

Smart Jobs and Consumers-Gold

Back to School Programme: Getting student alumni to be involved in greening of schools



1. Convince School

2. Gap Analysis



3. Recommendation



4. Implementation



5. Assessment

Smart Jobs and Consumers-Silver

Applied Leadership Program for Renewable Energies and Energy Efficiency in Mexico



Low Carbon Model Towns-Gold

Solar Powered City - Tainan Reaches for the Sun



Low Carbon Model Towns-Silver

Songdo, Korea



Thank You

Dr Eugenie Birch

Principal Investigator, Co-Director, Penn Institute for Urban Research

elbirch@upenn.edu

Amy Montgomery

Managing Director, Penn IUR

amyimo@upenn.edu

Alon Abramson

Project Manager, Penn IUR

alonabra@upenn.edu

<http://www.esci-ksp.org>

Session II

Knowledge Sharing

Smart Transport

Smart Park ICT Re-engineering Initiative

(Gold)

Dr Jason Yi-Bing Lin



Present

- Vice Chancellor, University System of Taiwan
- Chair Professor, [CSIE, NCTU](#)

Education

- B.S. in Electrical Engineering, National Cheng-Kung University, Chinese Taipei. June 1983.
- Ph.D. in Computer Science University of Washington, Seattle, WA. August 1990.
Thesis title: Understanding the Limits of Optimistic and Conservative Parallel Simulation (Thesis Advisor: Edward D. Lazowska).

Experience

- 2016.11- present: Vice Chancellor, University System of Taiwan
- 2014.03-2016.05: Deputy Minister, MOST
- 2014.01-2014.03: Deputy Minister, NSC
- 2011-2013: Senior Vice President, NCTU
- 2010-present: lifetime Chair Professor, NCTU
- 2007-2011: Dean, College of Computer Science, National Chiao Tung University (NCTU)
- 2004-2007: Dean (VP), Office of Research and Development, NCTU
- 2004-2010: Chair Professor, NCTU
- 2003-present: Adjunct Chair Professor, Providence University
- 2000-present: Adjunct Research Fellow, Academia Sinica.
- 1997-1999: Chairman, Department of Computer Science and Information Engineering (CSIE), NCTU
- 1995-present: Professor, CSIE, NCTU
- 1996: Deputy Director, Microelectronics and Information Systems Research Center, NCTU

- 1990-1995: Research Scientist, Bell Communications Research (Telcordia)

Awards

- Medal of K.T. Lee, Chinese Management Association , 2015
- Merit NSC Research Fellow Award, 2011
- National Chair Award, Ministry of Education, 2011
- TWAS Prize in Engineering Sciences, 2011
- IEEE Vehicular Technology Society "Top Associate Editor", 2011
- IEEE Region 10 Academia-Industry Partnership Award (for all the countries of Asia Pacific), 2010
- IBM Faculty Award, 2010
- IBM Shared University Research Award, 2009
- The 2008 Award for Outstanding contributions in Science and Technology, Executive Yuen.
- CT Ho Honored Award, 2007
- HP Technology for Teaching Higher Education Grant Award, 2007
- YZ Hsu Technology Cathedra Award, 2007 .
- ISI Highly Cited Scholar (top 1% in Computer Science; Author Publication Number: A0096-206-L; see <http://hcr3.isiknowledge.com>).
- Academic Publication Award of The Sun Yat-Sen Cultural Foundation, 2006.
- Academic Award of the Ministry of Education, 2006.
- Best Impact Award, IEEE Taipei Section, 2006 .
- Quanta's Outstanding Invention Award, 2005.
- W.Y. Pan Distinguished Research Award, 2005.
- Teco Award, 2005.
- Honory Medal of Information, IICM, 2005.
- Sitronix Endowed Chair Professorship, 2005-present.
- NSC Distinguished Researcher, 2005.
- K.T. Lee Breakthrough Award, IICM, 2004.

- Fellow, American Association for the Advancement of Science (AAAS), 2004.
Citation: Honored for distinguished contributions to the design and modeling of mobile telecommunications networks and for leadership in personal communications services education.
- Recognition of Excellence, Ministry of Economic Affairs. 2004. Citation: In recognition of his significant achievement in setting directions for the wireless communication industry of Chinese Taipei.
- Fellow, IET (IEE), 2004.
- Fellow, IEEE, 2003 through the IEEE Communications Society. Citation: For contributions to the design and modeling of mobile telecommunications networks and leadership in personal communications services education.
- Fellow, ACM, 2003. Citation: For contributions to mobile networks.
- Distinguished Research Award, National Science Council, 1997-1999, 1999-2001, 2002-2004.
- Distinguished Teaching Award, NCTU, 2002.
- Patent Usage Award, ITRI/CCL, 2001.
- Outstanding Youth Electrical Engineering Award, CIEE, 1998.

Smart Park ICT Re-engineering Initiative

Chinese Taipei

Managing Organization: The Ministry of Science and Technology (Department of Academia-Industry Collaboration and Science Park Affairs)



Overview

Since the inception of Chinese Taipei's first science park in 1980, the three major science parks located in Hsin-Chu, Taichung, and Tainan have attracted more than 800 businesses with a total of 270,000 employees. Science parks are by nature miniatures of a city, thus experience similar problems such as traffic congestion and insufficient parking spaces.

Under the jurisdiction of Ministry of Science and Technology, the three science parks are undergoing digital transformation. “**Smart Park ICT Re-engineering Initiative**” is implemented to drive changes and momentum.

Problems and Challenges

The Silicon Valley in Chinese Taipei, Hsin-Chu Science Park was originally planned with the capacity of 26,000 employees. Decades later, over 150,000 were employed with multiple growths. The other two parks experienced the same

employment growth. As a result, traffic problem is shared by all parks. There is a large intake of workers during peak hours as most people choose private vehicles to commute. It is a typical sight to see hordes of motorcycles swarm over the roads and automobiles lining up bumper-to-bumper. Traffic congestion and the deterioration of air quality have posed a severe threat to science park commuters and compromising the quality of life. An alternative solution is in great need to solve the nightmare.

Smart transportation is the answer!

Figure 1: Employment Growth of the Science Parks

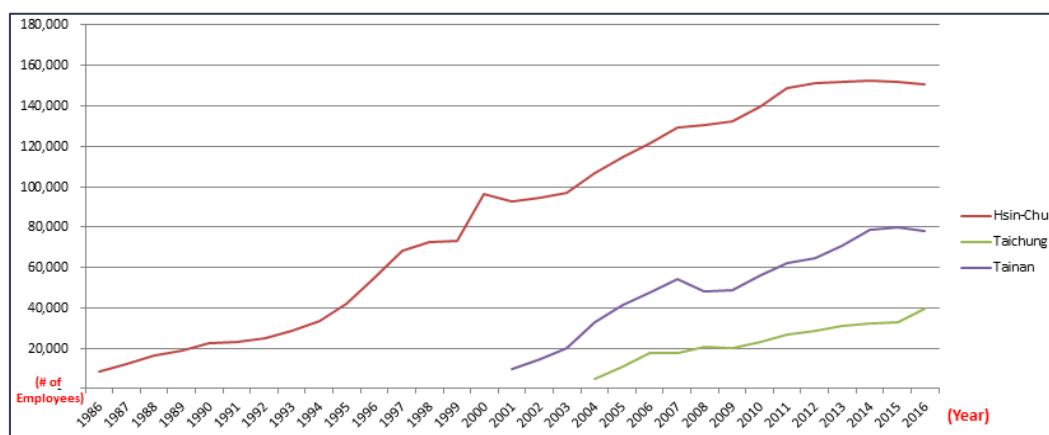

Solutions

■ Ministry of Science and Technology's Strategic Approaches

Aiming to renovate the ICT infrastructure and promote overall synergy of the three science parks, the following approaches were planned.

1. Launch the “Smart Park ICT Re-engineering Initiative” to transform the three parks into intelligent communities.

The Ministry of Science and Technology has launched the “Smart Park ICT Re-engineering Initiative” to transform the three science parks into digital eco-communities of innovation and sustainability. Powered by cutting-edge ICT technologies, the framework includes a “Smart Park Digital Platform” which governs and administrates a variety of data-driven smart traffic and environment solutions.

Figure 2: Framework of “Smart Park ICT Re-engineering Initiative”

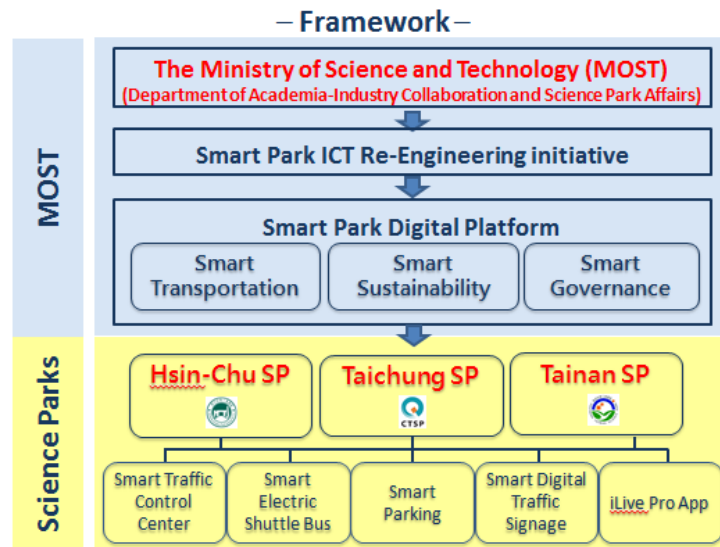

2. Implement “Smart Park Digital Platform” to collect big data and provide value-added insights.

“Smart Park Digital Platform” is a three-fold initiative with main focus on smart transportation, sustainability and governance. The sensor networks collect, store, retrieve and analyze data collected from two major sources: traffic and the environment. The platform adopts a dashboard design to visualize the data in an intuitive way. It also connects with government systems to maximize synergy.

It is the intention to open the collected data to echo government’s “data-driven, public-private collaboration, and people-oriented” policy. With the release of open data and the use of the parks themselves as experimental fields, it will encourage autonomous development of innovative APIs and benefit park residents’ welfare and well-being.

■ **The Science Parks’ Solution Implementations**

Under the governance and administration of the “Smart Park Digital Platform”, the three science parks carried out the following solutions to reach maximum energy efficiency while solving transportation pain points.

1. Smart Traffic Control Center

The operation process of the smart traffic control center includes data collection (through e-Tags and CCTVs), traffic management, traffic signal control, and traffic report. It provides dynamic traffic management and integrates with related systems, e.g. traffic signal system, travelers' information system, parking system, public transportation system, security system, etc. to enhance both traffic efficiency and safety. It is equipped with Active Traffic Management System (ATMS) to increase peak capacity and smooth traffic flows. CCTV is used for surveillance in areas that need monitoring. Under the management of the traffic control center, the driving time in the park can be reduced from 30 minutes to 20 minutes during peak hours, measurably improve traffic quality, reduce pollution, and increase efficiency.

2. Smart Electric Shuttle Bus

Electric vehicles are suitable choice for traffic congested areas with short driving distance, such as science parks. They are zero emission and highly efficient transit tools. Smart electric shuttle buses are used in the parks to partially substitute traditional fuel powered vehicles and encourage the use of public transportation. It provides intelligent transit services, reduces carbon emissions and fuel consumptions. The service routes connect the adjacent areas, train stations, High Speed Rail stops, and transferring bus stations.

The evolutionary smart device in the vehicles allows itself to communicate with other vehicles and infrastructures. The passengers can enjoy free Wi-Fi service and check dynamic bus schedule and arrival time via cell phone App and the LCD screen display at the bus stations.

In addition, the user-oriented DRTS (Demand Responsive Transit Service) is provided to reserve bus services during off-peak hours when the passenger

demand is low. It offers flexible routing, fills the services gap and reduces operating cost. It also encourages the use of public transportation services and reduces the traffic flow in the park areas.

The expected results in the application of EVs in each park are as follows.

Table 1: CO₂ reduction and fuel consumption saved per year in each park

Science Park	Hsin-Chu SP	Taichung SP	Tainan SP	Average
CO ₂ Reduction Per Year	45,605 Kg/Bus	8,938 Kg/Bus	21,645 Kg/Bus	25,396 Kg/Bus
Fuel Consumption Saved Per Year	17,491 Liters/Bus	6,500 Liters/Bus	8,300 Liters/Bus	10,764 Liters/Bus

3. Smart Parking

It is common to see long queues in front of a parking lot, drivers circling around looking for vacancies, or finding where they park their vehicles. Smart parking solution provides vehicle fast pass, available parking space signage, ticketless/cashless payment, security system, inquiry check, etc. Through the use of ticketless/cashless payment and car plate recognition systems, the entrance time into a parking lot is shortened to 3~5 seconds per car. The average time for a driver to locate a vacant parking space is limited to less than 3 minutes, resulting in a much favorable user satisfaction and site management.

Figure 3: Smart signage system displays occupancy and allows drivers to look for available parking spaces.



Take Hisn-Chu science park for example, it is expected to accommodate 434,000 vehicles and save a total of 21,662 hours every year with the deployment of smart parking solution. It will maximize parking space usage, provide hassle-free user experience, and reduce staffing requirement. It saves time and money. It also reduces fuel consumption and carbon emissions.

4. Smart Digital Traffic Signage

The traffic flow in science parks are subject to car accidents, road constructions, traffic controls, weather and the like. Smart Traffic Signage will be installed in science parks and the connecting areas to provide information and give instructions to road users. The content of the digital signage system includes warning, priority, information, direction, notice, etc. The system synchronizes with Taiwan National Freeway Bureau's dynamic traffic database every three minutes to report on traffic flow, thus assists route planning and avoids traffic congestion.

5. Launch "iLive Pro: Science Park Action Wizard" App to facilitate trip plans.

Cell phones are powerful and functional instruments once equipped with mobile apps. "iLive Pro: Science Park Action Wizard" is an integrated mobile App conceptualizes location-based services to provide park visitors with useful information like route schedules, maps, and best route navigation from user's current location to destination. The user interface is easy and infographic. It is a useful and efficient tool for traffic planners.

Figure 4: “iLive Pro: Science Park Action Wizard” App



Results and Potential Impacts

Traffic infrastructure is crucial to the economic vitality of a economy. Smart transportation with emphasis on people-orientation and sustainability not only promotes government's management efficiency but also ensures a safer and eco-friendly environment.

With the strategies and efforts, the following results and potential impacts are desired and achieved.

1. The scheme promotes overall synergy and performance of the three science parks in attaining an eco-friendly community and creates a LOHAS living environment. The success of the initiative can be learned and copied by other communities as well. The social and economic benefits are beyond their own immediate values and will encourage the welfare of the society.
2. The Smart Park Digital Platform orchestrates different solutions to enhance park management and efficiency. The resourceful database, once made public, can be a precious treasure and powerful engine to drive further value-added applications.
3. The comprehensive solutions provide value added functionality for both management and public users.

- The deployment of smart electric vehicles not only reduces the use of private vehicles but also helps to save energy and ensure traffic performance. The three parks are expected to significantly reduce 960,000 kg CO2 emissions and save 119,100 liters of fuel consumption every year. The use of EVs also encourages the development and prosperity of the manufacturing industry.
- The ticketless/cashless payment system of the smart parking solution reduces vehicle occupancy time and reduce overstay. It increases payment efficiency, allows maximum capacity from space available, improves site managements, adds to hassle-free customer satisfaction, and most importantly, ensures a sustaining environment.
- The dynamic, real-time digital signage solution promises a smoother traffic, better road management, and seamless traffic coordination with adjacent areas.

Under the strategic guidance of Ministry of Science and Technology, Hsin-Chu, Taichung, and Tainan Science Parks in Chinese Taipei are riding the tide of smart transportation to reach sustainability. The three parks have taken proactive steps to advocate practice of “Energy Smart Communities” which hopefully will drive Chinese Taipei in achieving the holistic innovation of sustainable energy.

-See more at:

<http://esci-ksp.org/project/smart-park-ict-re-engineering-initiative/>

Smart Park ICT Re-engineering Initiative



Organization:

Ministry of Science and Technology

科技廳
Ministry of Science and Technology



Hsinchu Science Park



Central Taiwan Science Park (Taichung)



Southern Taiwan Science Park (Tainan)

Challenges

With more than **270,000 employees** and the use of **private vehicles** over public transportation, deterioration of traffic poses great challenges to the 3 science parks in Chinese Taipei.



Traffic
Jam



Air
Pollution



CO2
Emission

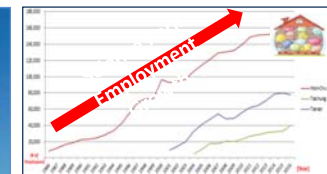

Traffic
Demand

Hierarchy of Synergies

“Smart Park ICT Re-engineering Initiative” is under Chinese Taipei’s “Asia Silicon Valley Development Plan”.



3

Initiative Framework

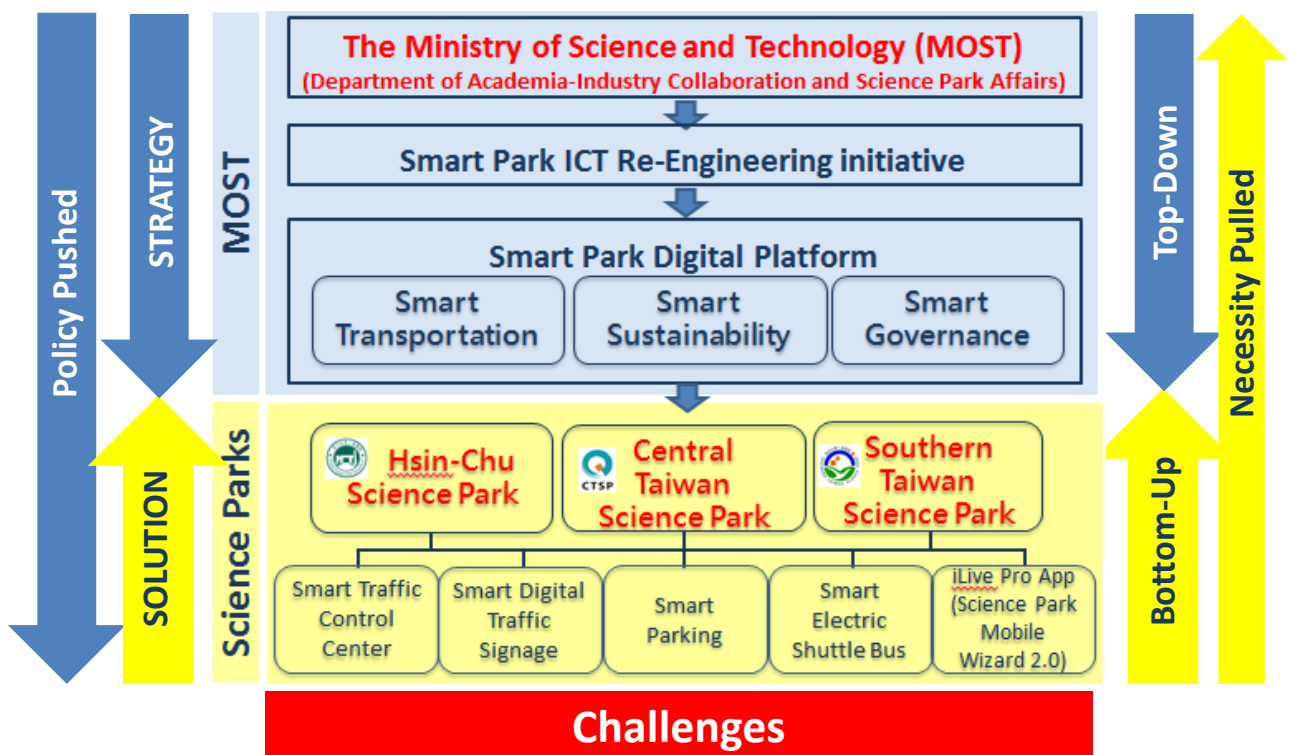

4

Smart Park Digital Platform

To enhance management and efficiency

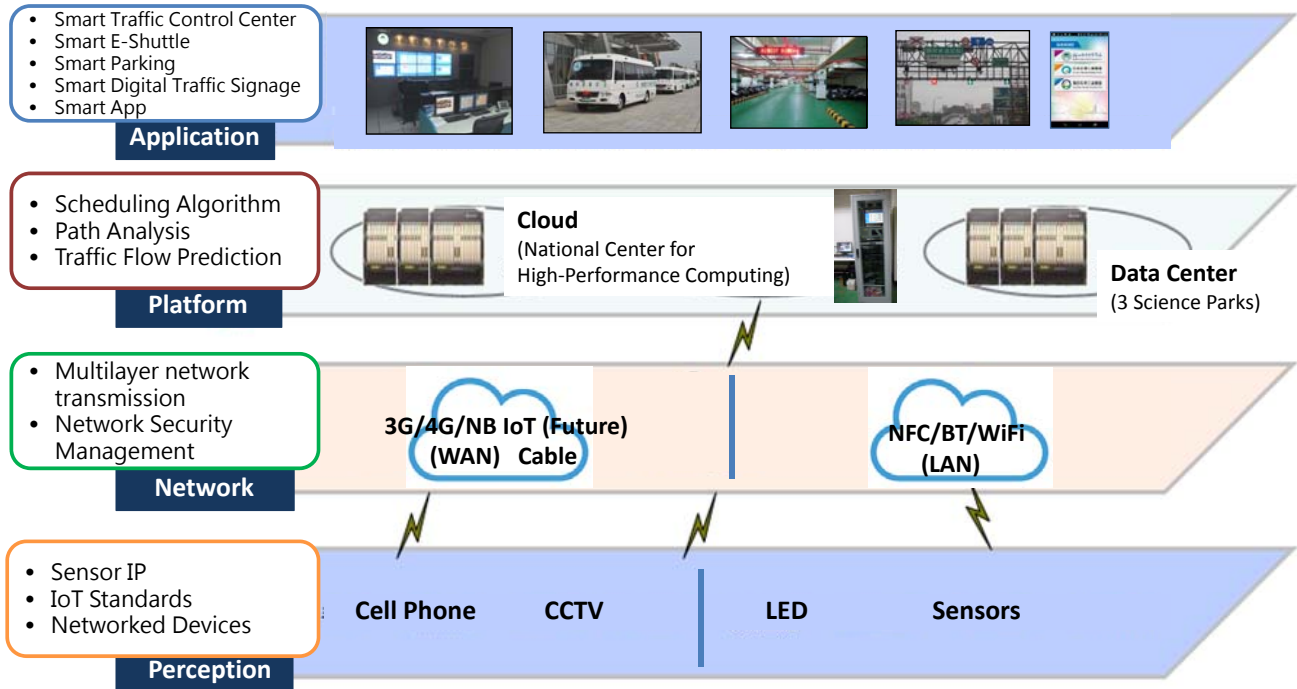

5

Smart Transportation Solutions

The Core Values of Smart Transportation

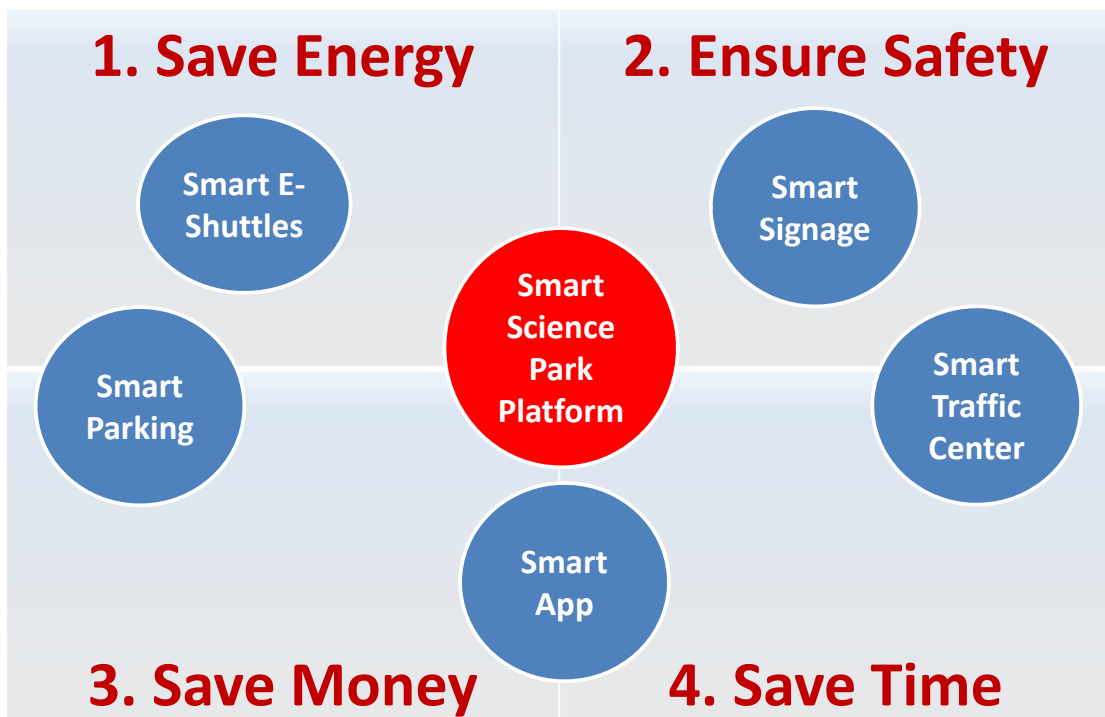

6

Solution 1: Smart Traffic Control Center

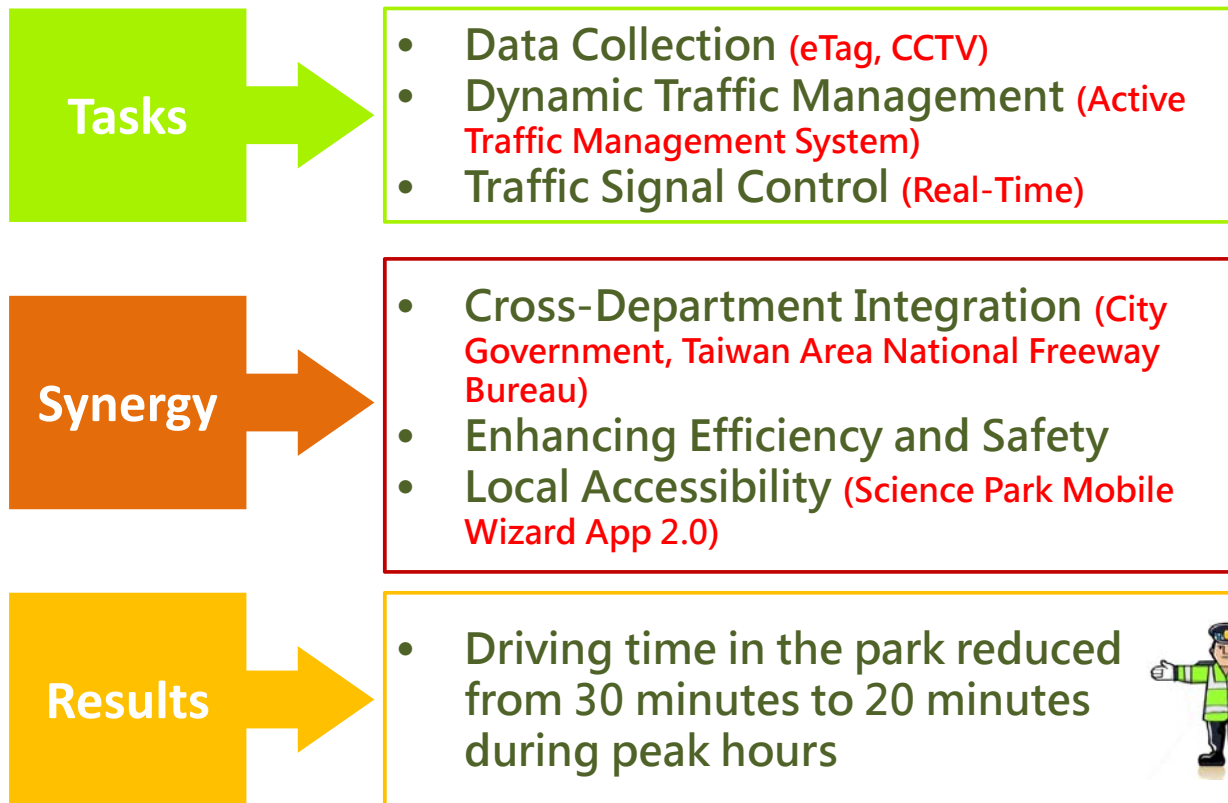

Solution 2: Smart E Shuttle

Benefits of Smart E shuttle:

- Environmental Protection
- Sustainable Resources
- Energy Optimization
- Free WiFi Access



Science Park	Hsin-Chu Science Park	Central Taiwan Science Park	Southern Taiwan Science Park	Average
CO2 Reduction Per Year	45,605 Kg	8,938 Kg	21,645 Kg	25,396 Kg
Fuel Consumption Saved Per Year	17,491 Liters	6,500 Liters	8,300 Liters	10,764 Liters

Solution 3: Smart Parking

- The time for entering the parking lot is **3~5 seconds** per car.
- The average time for a driver to locate a vacant parking space is **3 minutes**.



Vehicle Fast Pass



Parking Space Signage



Ticketless/Cashless Payment



Security System



Parking Control

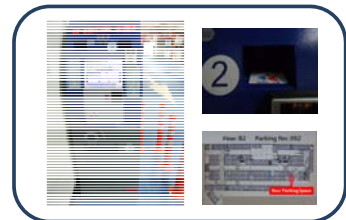

Inquiry Check

Solution 4: Smart Signage

Contents

Warning, priority, information, directions, notice, etc.



Synergy

Synchronizing with Taiwan National Freeway Bureau's dynamic traffic database **every 3 minutes**

Effects

- Traffic Route Engineering
- Route Planning Assistance
- Traffic Congestion Avoidance

Solution 5: Smart App



11

Potential Impacts



- The initiative promotes overall synergy and performance of the science parks and orchestrates various solutions to enhance the efficiency of science park management.
- Quantifiable results:
 - A total of **960,000** kg CO2 emissions reduced and **119,100** liters of fuel consumption saved.
 - A total of **21,662** hours of traveling time saved every year.
 - A **5%** reduction of travel time with the growing traffic demand (increase of cars every year).
 - The entering time to the parking lot is **3~5** seconds per car., and the average time to locate a vacant parking space is **3** minutes.

12

Conclusions



- Under the guidance of Ministry of Science and Technology (**MOST**), “**Smart Park ICT Re-engineering Initiative**” is launched to transform Hsin-Chu, Central Taiwan (Taichung), and Southern Taiwan (Tainan) Science Parks into **smart and sustainable parks**.
- The initiative will ensure science parks’ sustainable development and ultimate advocate as “**the best Energy Smart Communities**”.

13

Thank you!



Smart Buildings

**Smart City Shioashiya
“Solar-Shima”**

(Gold)

Ms Sumiyo Muraoka

Leader for Property Development Business Department

PanaHome Corporation



She has been in the project member of PanaHome Smart City Shioashiya in 2012.

The project members have designed the business concept of PanaHome Smart City Shioashiya.

She and her team have developed the scheme of the town management for the residents.

As the planner, she is in charge of developing new town project.

Smart City Shioashiya “Solar-Shima”

Japan

Managing Organization: Property Development Business Division, PanaHome Corporation

Building Type: Commercial (single-tenant)



Tucked away in a corner of Ashiya city in Japan’s Hyogo prefecture, Shioashiya is a town designed and developed by PanaHome, a subsidiary housing company of Japanese electronics giant Panasonic.

Shioashiya, which houses 400 detached houses as well as an 83-unit condominium complex, is PanaHome’s first attempt to develop a smart city as an independent project. But this has not stopped it from setting the ambitious aim of wanting to be a net zero energy city.

Launched in 2012, Shioashiya spans about 120,000 square metres, and is designed to accommodate 9,000 people; every house and community facility, as well as the overall town layout, has been designed to reduce energy use and maximize opportunities to use renewable power.

Each house in Shioashiya is fitted with rooftop solar panels, energy storage batteries, and a home energy management system which uses renewable energy when possible, and enables excess energy to be shared with neighboring homes. It also turns off household appliances when they are not in use.

The architecture of the detached houses is also geared towards energy reduction. An insulation technology known as Puretech and an Eco-Navi ventilation system keep the house warm during the summer and cool during the winter, with minimum energy required to do so. PanaHome has also made the condominium complex in Shioashiya net zero-energy through the use of a rooftop solar power system, and fuel cell units installed in each apartment. A fuel cell is a power generator which produces electricity from a chemical reaction between hydrogen and oxygen and it is widely hailed as a cleaner form of energy generation than conventional fossil fuel sources. Thanks to its innovative energy generation infrastructure, the condominium complex generates about 199 megawatt hours of energy per year. This exceeds the entire estate's energy consumption and the power that is sold back to the grid generates some US\$11,700 of annual income for the management association, says PanaHome.

Beyond its residences, the town's community centre, known as the Solar-Shima Terrace, is also fitted out with a solar system and storage batteries, and the town's layout itself also helps minimize energy use. This is because it uses an architectural technique known as passive design to make the most of ambient wind, sunlight, and wind — which is abundant, as Shioashiya is located between a sea and mountains — to cool, ventilate, and illuminate buildings in the town.

'PanaHome solutions such as zero-energy houses, smart home energy management systems and new energy have the potential to help Japan achieve its energy and emissions reductions targets, while offering residents a sustainable, vibrant and holistic community to live in,' says Kazuhiko Tanaka, managing director of PanaHome Asia Pacific.

'The technologies showcased in Shioashiya are ideal for scaling up across Japan, and for other Asian countries which are pursuing greater energy efficiency in their cities and buildings,' Tanaka adds. (Source: Eco-business)

More information on the project can also be found through Panasonic or PanaHome(Japanese notation)

Strategy

Innovativeness

1) What is the origin of this innovative technology/concept?

Smart City Shioashiya is carrying out two endeavors that have never been done before in Japan.

1. Aim at net zero energy*1 in the whole town comprising detached houses (about 400 households) and condominiums (83 units), for the first time in Japan.*2
2. Mount fuel batteries in all condominiums for the first time in Japan,*3 to enhance energy efficiency.

To realize net zero energy in the whole town, all detached houses are equipped with the Panasonic's "Energy Creation-storage Linked System for Home" as smart houses. This system is able to suppress peak power as well as secure power in the event of power failure. Meanwhile, all condominiums are also equipped with a fuel battery in each unit. Their roofs are installed with 56 kW solar power to generate power and also indoor 15 kWh large-capacity storage batteries to store these energy. Those generation systems create electric energy equivalent to the total amount of power consumed by the condominiums.

The economic benefits to residents is a feature. Annual lighting and heating*4 costs of the houses can be decreased to about 70,000 yen, while for condominiums to about 60,000 yen less than for general condominiums using electricity and gas. Excess power from generated solar power is sold, providing an annual income of about 1,330,000 yen, which is used as income by the condominium management association.

**1: Energy used and created are offset, and become basically zero.*

**2: As of August 2013. Mass detached housing estate exceeding 400 households comprising detached houses and condominiums. (PanaHome survey)*

**3: As of August 2013. In condominiums exceeding 80 households (PanaHome survey)*

**4: Heating means boiling hot water*

2) Is the policy design innovative which can encourage financial support and public-private partnership?

The building of an eco-friendly smart city on reclaimed land in Shioashiya, based on an agreement with Hyogo Prefecture, enhances the appeal of the town itself and will contribute to increased population (Planned population: about 500 households, 1500 persons)

Inspiration

1) Can this idea inspire later/subsequent cases?

In Japan, this idea is already expanding. By 2018, PanaHome aims to make 80% of its newly built houses in ZEH (net zero energy houses),*5 building smart cities in Kusatsu (Shiga Prefecture) and Fujisawa (Kanagawa Prefecture) as well as government-managed ZEH smart houses, and proposing these as standard specifications for detached houses. PanaHome is also building smart condominiums in Tokyo, Osaka, Nara, and other locations, equipped with advanced energy facilities such as solar power generation, storage batteries, and fuel batteries.

**5: Houses in which energy used and created are offset and basically zero.*

2) What domains have been enlightened by this policy?

Enlightened are domains building independent towns that locally generate and use energy, and domains building CCP*6 towns, which can sustain life even during

disasters, provided that the increased number of smart cities can cut peak power usage by leveling the regional power supply and demand and combining solar power generation with storage batteries.

In addition, by conveying the significance and merits of smart cities to residents and gaining their understanding, it can help foster their energy-saving awareness.

*6: Community Continuity Plan

Clearness

1) Are there any open and transparent channels of public communication?

Smart City Shioashiya is introduced on PanaHome's website. As for smart condominiums, residents are presently disclosing their household power measurement data to the Japanese government for five years from 2013 to obtain subsidies from the Japanese government and Ministry of the Environment.

2) Are there any differences between this policy and other similar policies?

Led by residents, the whole town comprising smart houses and smart condominiums for 400 households is working on enhancing energy efficiency.

In the wake of the Great East Japan Earthquake (March 2011), town management considers safety and peace of mind by incorporating disaster prevention measures in the town planning concept.

Measure

Practicability

1) Has any effective measures for moving ahead been made?

The Japan policies of the Japanese government promote ZEH in the household sector, which comprises about 30% of the total power consumption in the economy. Owners of detached houses and condominiums proposed by PanaHome in accordance

with these Japan policies are eligible for various grants for energy saving equipment such as home energy management systems (HEMS) and solar power generation. In addition to reduced initial costs, the use of energy saving equipment can also reduce operating costs such as lighting and heating expenses, providing not only economic merits but also helping to spread smart houses and smart condominiums.

Since the town of Shioashiya is on the coast, smart condominiums are designated as evacuation areas in the event of disasters such as tsunami. Such aspects not only provide residents with peace of mind but also help promote the project.

2) Are there any numerical goals for reference?

The goal for the whole town is to create 28,700 GJ/year of energy to realize being a net zero energy town (ZET). For each smart house to become ZEH, the goal is to create 56 GJ/year of energy on average.

Replicability

1) Can the ideals, methods or techniques be applied internationally?

This depends on the living standards, energy business, and laws and regulations of the respective countries, but the techniques are applicable. Currently, we are proposing some of our concepts such as town management for use overseas.

2) Are there any specific SOPs or responsible organizations?

Remote control of HEMS-related equipment conforms to protocols of the international standard ECHONET Lite.

PanaHome's unique efforts include establishing town building guidelines and standard specifications for homes and buildings.

Cost-effectiveness

1) Will it be cost-effective to implement?

According to PanaHome's unique lighting and heating expenses environment simulation results, the electricity costs of smart houses can be reduced to about 70,000 yen.*7

By using various subsidies, home facility prices can also be reduced.

By installing solar power generation systems in the community center for residents within the smart city, power for two days can be provided in the event of power failures during disasters.

*7: Calculated based on electricity charges as of 2013 (PanaHome survey)

2) Is there any measurable reduction of emissions or energy use?

Calculation data has been obtained from the simulation of the lighting and heating costs environment developed by PanaHome for use in explaining the system to customers.

Smart condominiums residents are currently submitting measured electricity data to the government as a condition for receiving subsidies from 2013 to 2017. PanaHome, however, does not have this information.

Consistency

1) Are adopted measures consistent with energy policies and strategies?

As the housing company of the Panasonic Group, PanaHome has been carrying out its mission to enrich people's lives by providing homes based on the visions of Panasonic group founder Konosuke Matsushita, which we have inherited for more than 50 years. One such vision is the concept of environmental friendliness. The pursuit of energy efficiency is an important element of this. For this reason, we strive to make each house a smart house and when these houses are grouped together, as a smart city. Our goal is to make such towns net zero energy towns (ZET).

2) Are there any long-term measures or implementing organizations for this project?

Leading the development of Smart City Shioashiya, PanaHome is responsible for town development, as well as the design, construction, and sale of homes. It will also be involved in after-services for homes over the long term.

In establishing town communities, residents set up a corporate “residents management association” and carry out activities to enhance the town’s asset values using their community center, a common asset, as a base. PanaHome-related companies support such activities.

Performance:

Completeness

1) Is the achievement scale measurable?

The lighting and heating costs of each home are calculated from a lighting and heating cost environment simulation to adjust parameters to target values and manage their progress.

2) Will it make considerable success in project goals?

For smart houses, being based on ZEH, it should be possible to basically realize ZEH for each individual home. As of 2016, about 25% of the entire plan (about 110 homes) had been completed. PanaHome will continue sales in the future.

The smart apartments have been completed and PanaHome has sold all 83 units.

Verifiability

1) Are there any data presented to support the project?

For smart houses, the calculation results of lighting and heating cost environment simulation can be provided.

2) Are there any supportive measurements or references for the provided data?

■ The calculation results of lighting and heating cost environment simulation - a smart house of Smart City Shioashiya

floor space m ²	solar power generation system		Panasonic Energy Creation-storage Linked System for Home	consumption				solar power		Achievement rate of ZEH	The annual lighting and heating expenditure of a house			
	total	direction		power		gas		PV			spending		income	balance of payments
				kWh	GJ	kWh	GJ	kWh	GJ	%	power	gas	power sale revenue	
123	4.76kW	south	○	5,584	54.5	0	0.0	5,744	56.0	103%	76,936yen	0yen	153,938yen	77,002yen

- * In the case of standard model plans, calculated by all electric.
- * For lighting and heating costs, the unit price at the start of the development project (as of 2013) is shown.
- * For the simulation, PanaHome's calculation program is used.

Impacts

1) Will it make a significant change in the field of energy efficiency and energy savings?

By promoting smart cities, we aim to balance energy efficiency and savings by cutting peak usage of regional power supply and demand, and maximize self-use of regional energy from solar power generation. In the future, we will aim for horizontal expansion of highly universal micro grid systems on a scale of 100 units, and carry out discussions with specialist organizations and others linked to the development.

2) Will it impact multiple operational areas or just one specific area?

Once the micro grid system, currently in the review stage, enters the execution stage, we will also take into account the feasibility of exporting it to regions with weak utility grids inside and outside the economy.

-See more at:

<http://esci-ksp.org/project/shioashiya-japan/>

PanaHome Smart City Shioashiya

Introduction of Project

PanaHome Corporation

Introduction of PanaHome

PanaHome is a housing company of the Panasonic Group.

Ability to make proposals for living
PanaHome



Technical skills
Panasonic

- Quality/ Performance of house
- After-sales support system

- Energy technologies
- Energy saving equipment

Provide houses with high added values generated by the multiplier effect

Efforts for Smart City

We solve social problems and regional issues and create a new life style and values through town development.

Environment
preservation

Energy
saving

Disaster/crime
prevention

Communication
among multiple
generations

**Provide a foundation of
safe and secure living**



Smart City Shioashiya <Background of Project>



Hyogo
Pref.

Japan

Public-Private
partnership

Natural
environment

Living
environment

**The largest smart city project in western Japan utilizing
a wonderful natural environment and advantage of scale**

Smart City Shioashiya <Town Concept>

Development area: 122,940 m²
Planned households: Approx. 500
Planned population: Approx. 1,500



SMART ENERGY

Smart House

=

Energy technologies

+

Basic building performance

Smart House <Employment of Energy Technologies>

A solar cell system and a storage battery are combined to use power without waste.



▶ Solar power generation + Storage battery

Power generation efficiency of the highest level in the world.



▶ Smart HEMS

Visualization of energies and control of equipment such as air conditioners.



▶ Eco item

Commitment to energy saving and comfort.



LED lighting
Outlet for EV charger



Smart House <Basic Building Performance >

▶ Seismic structure

PanaHome's unique seismic structure that withstands a big earthquake and repeated earthquakes.



Seismic performance

▶ Keeping beautiful appearance

External tile wall with self-cleaning effect realized by photocatalytic technology. Economical with reduced maintenance cost.

Energy saving
Economy



(1) Stain-resistant

(2) Photocatalysis makes dirt less adhesive

(3) Rain washes away dirt

(4) Ventilate

Comfort
Energy saving
Economy

▶ Comfortable indoor air environment

High insulation performance and a ventilation system that utilizes terrestrial heat reduce the heat loss to realize a comfortable indoor environment with advanced energy saving.

(3) Supplies clean air from under the floor to each room

(1) Supplies outside air from under the floor

(2) Purifies air with sedimentation

Annual Balance of Standard Model Plan of Smart House (Estimate)

(Total floor area 123.05 m²)

	Smart House (All-electric type)	General house
Smart specification	<ul style="list-style-type: none"> •Solar cell 4.76 kW •Storage battery 5.60 kWh •HEMS 	—
Power consumption	5,584 kWh · 54.5 GJ	6,245 kWh · 61.0 GJ
PV power generation	5,744 kWh · 56.0 GJ	0 kWh · 0.0 GJ



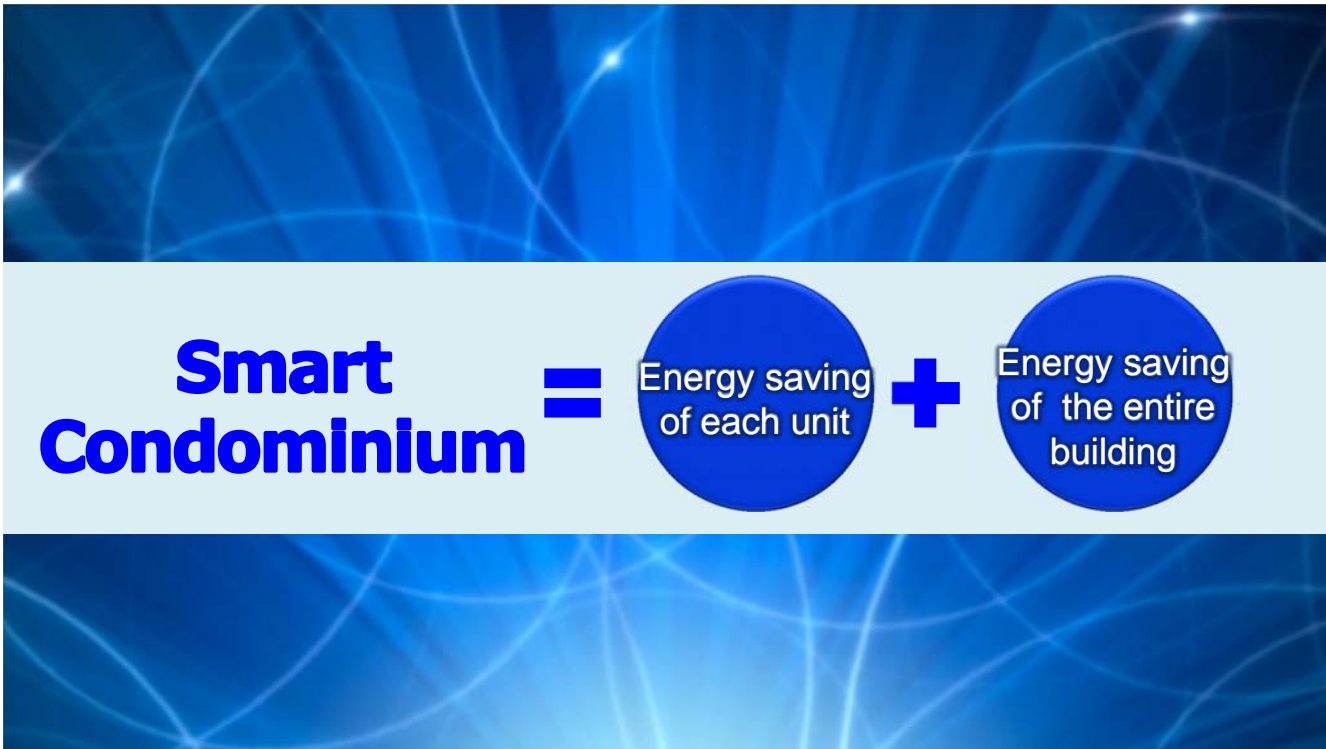

Smart Condominium Overview

Power generation (Approx. 11 kW) → Power storage → Power generation (Approx. 45 kW) → Power selling

**Total of units 83 (sold out)
Five stories above ground,
three buildings**

Smart Condominium Overview

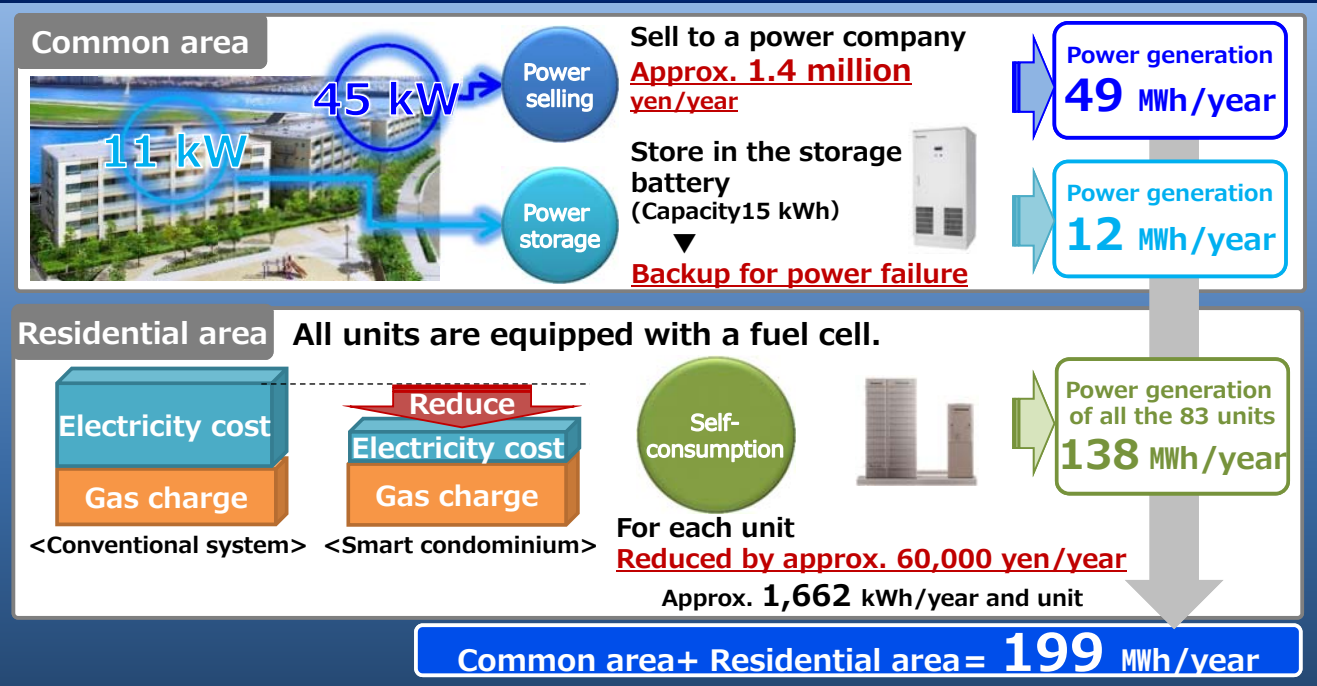

Goal of Entire Town

We will promote efficient use of renewable energies and improvement of energy saving in buildings in the entire town.



For Future Development of Smart City

PanaHome



Panasonic



PanaHome

SMART CITY



Smart Buildings

**Energy Conservation Virtue at
Huachiew Chalermprakiet
University**

(Silver)

Dr PRACHAK POOMVISES

Associate Professor

President

Huachiew Chalermprakiet University

Education

D.V.M. (Doctor of Veterinary Medicine)	Chulalongkorn University
D.T.V.M. (Tropical Veterinary Medicine)	University of Edinburgh, U.K
Ph.D. (Tropical Animal Health)	University of Edinburgh, U.K
Dip. In Vet. Epidemiology	University of Guelph, Canada

Past-Experiences

- Head, Department of Veterinary Medicine, Chulalongkorn University,
- Associate Dean, Faculty of Veterinary of Science, Chulalongkorn University,
- Director of Center of Academic Resources, Chulalongkorn University,
- Director of the first Internet Gateway in Thailand at Chulalongkorn University,
- Director of IT-Campus (Uninet) Project, Ministry of University Affairs,
- President, Thai Library Association
- President, The Association of Veterinary Laboratory Diagnosticians,
- President, World Association of Veterinary Laboratory Diagnosticians,
- Vice President, Huachiew Chalermprakiet University.

Current Positions

- President, Huachiew Chalermprakiet University,
- Member, Thailand-China Business Council Committee,
- President, The Thai Association of Veterinary Laboratory Diagnosticians,
- Past President, World Association of Veterinary Laboratory Diagnosticians,

Energy Conservation Virtue at Huachiew Chalermprakiet University

Thailand

Managing Organization: Huachiew Chalermprakiet University

Building Type: Commercial (single-tenant)



Project Abstract

Huachiew Chalermprakiet University opened in 1992. The university has 886 staff many of whom have been working with the university from its early days. The university working days are from Monday to Saturday (3,744 hours per year). Aside from maintaining full-teaching operations, the university also strives to have impeccable green credentials through a low energy consumption profile.

From 2012 to 2015, the university has engaged in an energy saving program and this has resulted in reduced energy consumption. To achieve the goal of energy efficiency, Huachiew Chalermprakiet University has created a culture of energy saving in all levels of university operations. We have encouraged employees to be personally involved in energy conservation activities. There are team members, who lead the campaign to reduce the carbon footprint. It started with energy conservation training for every staff so they could guide others and apply their know-how and skills in their working routines. We also encourage students to join the campaign by using energy economically, during student activities within the university. Then there are also

ongoing outreaches to the community. Activities are conducted to educate students about energy saving as part of our corporate social responsibility program.

For the past four years through energy conservation activities (both investment and non-investment), we have reduced energy consumption by more than 2,620,435 kWh, which is equal to 1,903.79 tons of CO₂ emissions. The reduction of energy consumption gave us a total savings of over 10.99 million baht with the average ROI of 3.37 per year. Recently, Huachiew Chalermprakiet University was awarded the **Best Energy Saving Building of MEA 2015 from the Metropolitan Electricity Authority of Thailand with prize money of 2 million baht. Also we were honored at the Thailand Energy Awards 2016 and ASEAN Energy Award 2016.**

A culture of energy saving was not easy to create but at Huachiew Chalermprakiet University, **WE CAN**. It is our firm belief that our success story is driven by our staff, who is committed to the energy conservation program.

Strategy

Inspiration

From H.M.King Bhumibhol Adulyadej's words in June 24, 1994, "May you manage the university along the path of righteousness.", we reminded ourselves in thinking, speaking and doing to follow our King's words. We aimed to apply his words in conducting our energy conservation projects.



“May you manage the university along the path of righteousness.”

Clearness to Sustainable Energy Saving

Participation is the heart of success at Huachiew Chalermprakiet University. Our energy conservation achievement originated from our directors and managers, joined by our staffs, students and other organizations. These various parties have driven energy conservation policies and activities, and then eventually became Huachiew Chalermprakiet University’s culture in energy conservation. We also established policy committees, energy management committees and energy audit committees. We have many energy conservation activities which were succeeded by participations from every level of Huachiew Chalermprakiet University’s people. Some of these projects are the “Bike, Grow, Save” and R2I Project.

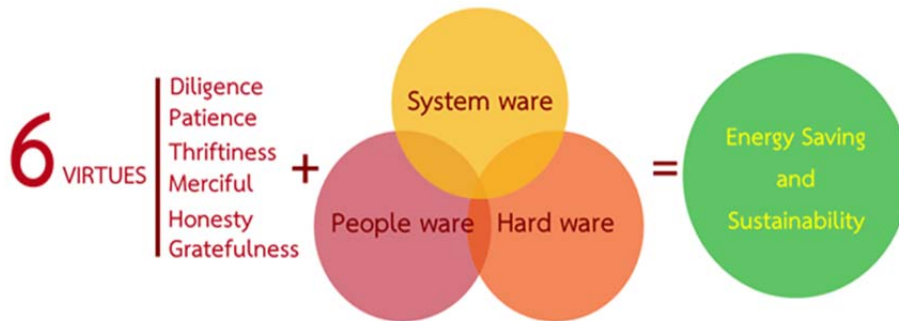

Huachiew Chalermprakiet University is guided by Assoc. Prof. Dr Prachak Poomvises who committed to “RUN THIS UNIVERSITY WELL” and the “6 Huachiew Chalermprakiet University virtues”. This eventually became our “VIRTUE ENERGY CONSERVATION”. We also have concrete policies and clear goal in mind. Along with our staff, continuous funding and evaluation, we can accomplish energy conservation activities. Together with a systemic energy management, Huachiew Chalermprakiet University has been successful in attaining sustainable energy conservation.

ENERGY CONSERVATION VIRTUE



In order to reach our energy conservation goal, Huachiew Chalermprakiet University had announced energy conservation policies and established organizations to drive these policies and do actions in energy conservation. These organizations were established from every level of Huachiew's staffs, supported by sufficient funding from the university with continuous evaluation and development. Not only we focused on finding appropriate energy saving policies and actions, but we also created a culture of organization in energy conservation by encouraging teamwork, educating and training. Thus, our people can apply energy conservation to their works and lives.



Innovativeness

1. Classroom Energy Monitoring

Huachiew Chalermprakiet University has installed energy monitoring device in our classrooms which will enable us to manage our classrooms more efficiently. In the near future, we will be able to adjust our classrooms and the number of students in those class to optimize energy consumption.



2.Green Bus Station and Energy Saving Security Point

Aiming to elevate scenery in Huachiew Chalermprakiet University, we have planted many trees and plants in our campus. These trees and plants do not only make our university livelier, but also reduce solar heat transfer to our facilities.



reduce temperature Add oxygen Energy saving

3. Loss Nay Installation

Indoor Air Quality is a crucial factor for our students learning capacity. Hence, we have installed Loss Nays or Air Exchange Machine in our classrooms. These machines do not only increase our classrooms' indoor air quality, but they also reduce energy consumption in those classrooms.

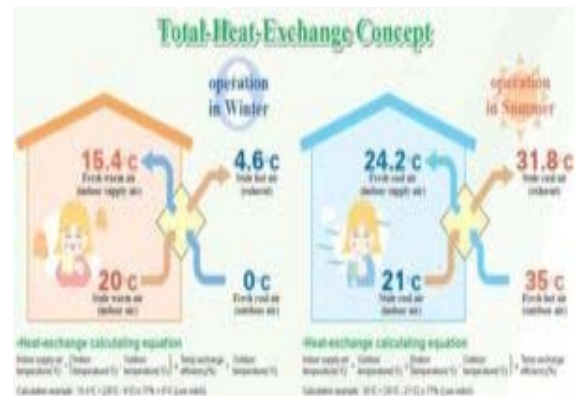

4.Student Scholarship from energy saving

In doing energy conservation, we believe that these benefits will, at last, be given to the next generations. At Huachiew Chalermprakiet University, those money savings from our energy conservation projects will be given as scholarships to our students.



For over 5 years of energy conservation, we have funded more than 34.15M Baht investment in peopleware, systemware and hardware. These have resulted in a total energy saving of over 2,620,434 kWh.



Measures investments in 2013-2015

Measure

Replicability

Establishment of Organization of Energy Management

Huachiew Chalermprakiet University has established an energy management organization since 2011, in order to succeed in its sustainable energy conservation goal. The organization consists of the Chairman of Energy Management who is Assoc. Prof. Dr Prachak Poomvises himself, the Board of Committees who apply policies into everyday works, sub-committees who analyze and develop energy saving projects and a working group which is consists of various people from each department.

Organization of Energy Management

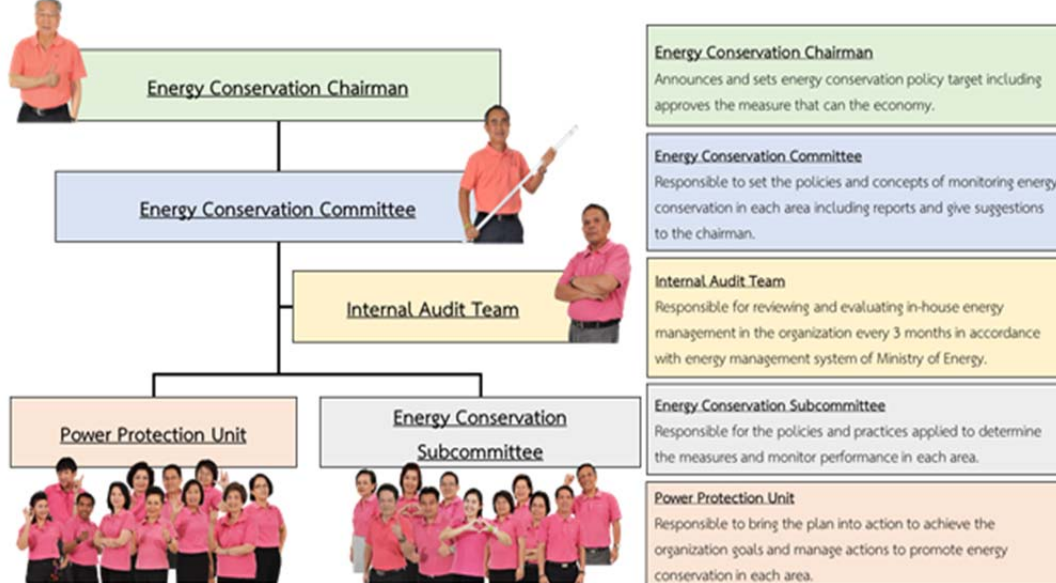

Employee Development and Educational Training

At Huachiew Chalermprakiet University, we have continuously educated our people in energy conservation. Focusing on every level of our staffs and students, our people had a clear understanding about energy conservation which will lead to firm energy conservation awareness. In order to do so, we invited specialists in energy conservation from the Ministry of Energy and energy consultant firms to educate and train our people in energy conservation. We also observed and learned from other successful organizations, and brought and applied those knowledge to our organization; some of them can even be applied at our staff's house.



Table 1: Energy Conservation Training Courses

Name of Course	Day / Month / Year	Quantity (People)	Quantity of Training (Time)
Internal Training			
New Staff Orientation in Energy Conservation	16 Oct. 2013	60	1
Energy and Environment Seminar	21 Oct. 2013	24	1
Energy Awareness Seminar I	11 Nov. 2013	39	1
Basic Energy Saving Seminar	16 Nov. 2013	55	1
Energy Management Training	21 Nov. 2013	27	1
Basic Energy Saving Seminar	26 May. 2014	32	1
New Staff Orientation in Energy Conservation	29 Jun. 2014	69	1
New Staff Orientation in Energy Conservation	6 Aug. 2014	18	1
Energy Awareness Seminar II	17 Dec. 2014	55	1
New Staff Orientation in Energy Conservation	1 Jul. 2015	63	1
New Staff Orientation in Energy Conservation	8 Jul. 2015	13	1
Basic Energy Saving Training	17 Jul. 2015	26	1
Collaborative Energy Conservation Training	13 Aug. 2015	52	1
Collaborative Energy Conservation Training	13 Aug. 2015	46	1
R2I : Routine To innovative changed to “Routine to Innovative”	18 Sep. 2015	66	1
New Staff Orientation in Energy Conservation	14 Dec. 2015	45	1
New Staff Orientation in Energy Conservation	14 Dec. 2015	71	1
New Staff Orientation in Energy Conservation II	18 Dec. 2015	74	1
External Training			
Learning Energy Conservation at Phayathai Sriraja Hospital	24 Feb. 2013	84	1
Learning Energy Conservation at Ayutthaya Hospital	20 Jan. 2013	88	1
Technology Demonstration Seminar	25 Oct. 2013	5	1
7 th Energy saving for H.M. King Bhumibol Adulyadej	6-7 Mar. 2014	16	1
Electrical system maintenance to increase energy efficiency	27 Jun. 2014	2	1
Preparing for EnMR (ISO 50001)	26 Nov. 2014	1	1
Preparing for ISO 50001	14-15 Aug. 2014	2	1
Senior energy manager training: Practice of	17- 21 Nov 2014	1	1

Name of Course	Day / Month / Year	Quantity (People)	Quantity of Training (Time)
electrical system			
Senior energy manager training: Theory of electrical system	12-16 Jan. 2015	1	1
8 th Energy saving for H.M. King Bhumibol Adulyadej	5-6 Mar. 2015	10	2
Learning Energy Conservation at King Mongkut's University of Technology Thonburi (Thailand)	10 Jul. 2015	54	1
Learning Energy Conservation at Phayathai 2 Hospital	10 Jul. 2015	54	1
Learning Energy Conservation at Energy Saving Building of H.M. King Bhumibol Adulyadej	15 Jul. 2015	49	1
Learning Energy Conservation at Richmond Hotel (Thailand)	15 Jul. 2015	49	1

Applicabilities and Knowledge Management

To succeed in energy conservation and make it applicable with everyday works, we conducted innovative energy saving contests (R2I: Routine to Innovative for Energy Saving) to encourage our staffs and students to apply energy conservation ideas in their lives.



These projects resulted in reduction in energy costs, work processes, man-hour and energy consumptions. In order to enlarge the sphere of impact from this knowledge, Huachiew Chalermprakiet University conducted a seminar to present and discuss each of the ideas, with Miss Laksawan Wongworrakan, the director of Richmond Hotel as the guest speaker on “Energy Saving Success in a Hotel Facility. We also received honor from Mr Sanit Ungsusint, the Vice-President of Metropolitan Electricity Authority to open the seminar, which was participated by more than 50 organizations.



Innovative energy saving contest (R2I: Routine to Innovative for Energy Saving)

Public Relation about Energy Management through Various Channels

Aiming For other organizations to have opportunities to learn from our success in energy conservation, we told our stories through various channels including magazines, websites, Facebook and TV channels.



Magazine Energy Saving



MONO29 TV Channel and Spring News

Activities: Projects / activities applied for internal and external of organization

With our “Virtuous Energy Saving” campaign, we wholeheartedly applied our motto and energy saving ideas to serve our society through various activities such as sports day, and energy conservation trip in Huachiew’s campus. The activities and projects were conducted in more than 100 communities by our staffs and students who are determined to serve our society using our virtuous energy conservation project.



Social healthcare services



3P Activities



Energy



Day



2013-2015



Planting mangroves



Walking to promote the energy activities



Walking to stimulate energy saving activities

Our energy conservation activities were participated by both internal and external organizations. These activities were aimed to educate our staffs and students about energy conservation through the various aspects of the activities. From 2013-2015, Huachiew Chalermprakiet University has conducted more than 27 energy

conservation activities. We also have a PR-Board, a website and a Facebook with more than 15,000 followers, in order to let other organizations learn what we do.

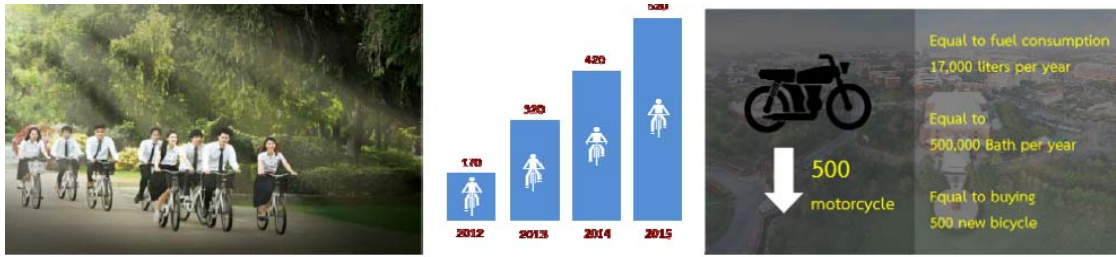

The White Bicycle Project



A cigarette factory
Use more than
60,000 MWh a year.

Local Non-smoking Campaign



Facebook and website releases

Encouraging bikers to wear helmet

Huachiew Chalermprakiet University, Bangchalong District and Bangplee Police District formed a team to launch a project to encourage bikers to wear helmet, in order to reduce risk from accidents.

Safe, low energy consumption



Practicability

In evaluating the results in energy conservation, apart from the total energy saving, Huachiew Chalermprakiet University evaluated the Specific Energy Consumption Index (SEC Index). This indexes consist of (1) Total Heat Energy

(MJ)/Area (sq.m.), (2) Total Electricity (kWh)/ Staffs and Students (Person), and (3) Total Electricity (kWh)/ Area (sq.m.). Due to our energy conservation policies and projects, Huachiew Chalermprakiet University's energy conservation and SEC Index have continuously reduced since 2012.

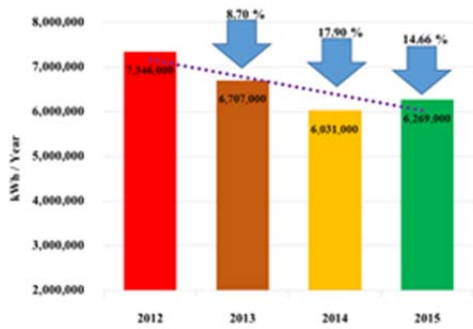

Energy Consumption from 2012 - 2015

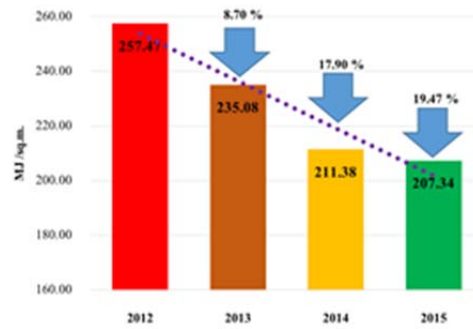

Energy Efficiency Index 2012-2015 (MJ/sq.m.)

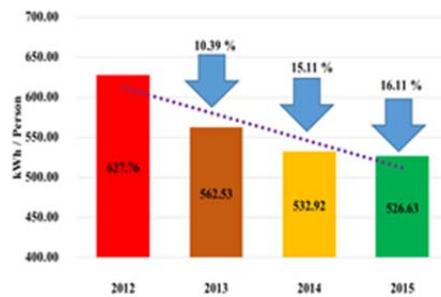

Energy Efficiency Index 2012-2015 (kWh/person)

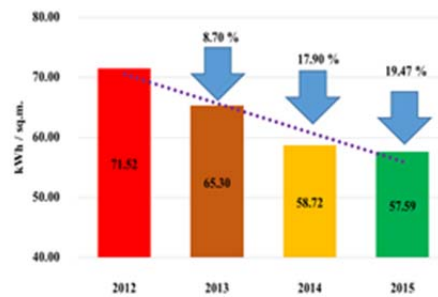

Energy Efficiency Index 2012-2015 (kWh/sq.m.)

Cost-effectiveness

Huachiew Chalermprakiet University has done various energy conservation activities, both non-investment and investment projects. In non-investment projects, we focused on creating energy conservation awareness. Thus, our staffs and students can practice and pass on these ideas to the society. For investment projects, we considered three aspects: (1) RESULTS (Sustainable and Consistency), (2) ROI (Return on Investment) around 3-5 years, and (3) SUBSIDY from the government.

From 2013-2015, Huachiew Chalermprakiet University reduced energy consumption by more than 10.99M Baht with an average ROI of 3.11 years, and with subsidy from DEDE Subsidy 80:20 Project. Huachiew Chalermprakiet University also

considered projects with ROI of over 5 years, but be able to become learning centers in energy conservation.

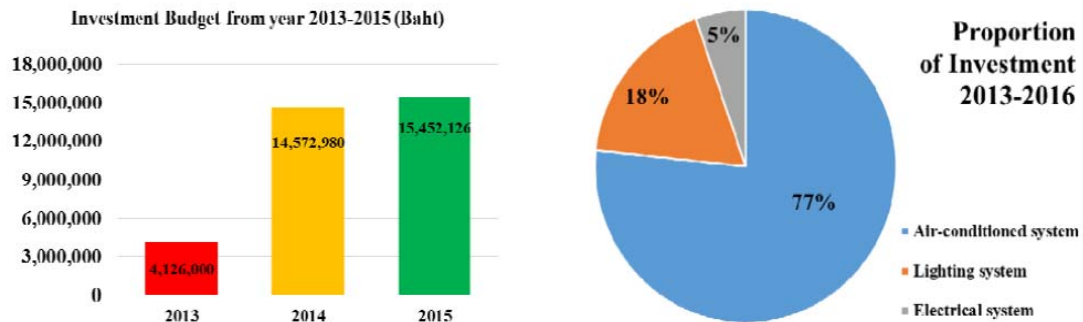

Table 2: Energy Conservation activities during 2013-2015

Energy Conservation Activity	Conservation per year						Invest. (THB)	Payback Period (year)
	Electricity			Fuel				
	(kWh)	(THB)	CO ₂ Reduced (TON)	(MJ)	(THB)	CO ₂ Reduced (TON)		
Measures from non-investment (staff participation)								
Uninstall light bulb in over necessary areas	100,740	423,108	73.19	-	-	-	-	-
Cafeteria's 1 st floor lighting zoning	44,712	187,790	32.48	-	-	-	-	-
Seasonal timer for lighting on University wall	1,169	4,912	0.85	-	-	-	-	-
Library Building lighting zoning	14,904	62,597	10.83	-	-	-	-	-
Library Building HVAC control system	56,700	238,140	41.19	-	-	-	-	-
Measures from investment								
Installing rope switch for lighting	4,968	20,369	3.61	-	-	-	30,000	1.47
Replaced to chiller 200 Ton (auditorium Phase1)	127,296	521,914	92.48	-	-	-	3,100,000	5.94
Replaced to inverter air-conditioner bookstore areas	43,143	181,201	31.34	-	-	-	950,000	5.24
Replaced to LED in bookstore areas	3,629	15,241	2.64	-	-	-	46,000	3.02
Total for 2013	397,261	1,655,271	288.62	0	0	0	4,126,000	2.49

Energy Conservation Activity	Conservation per year						Invest. (THB)	Payback Period (year)		
	Electricity			Fuel						
	(kWh)	(THB)	CO ₂ Reduced (TON)	(MJ)	(THB)	CO ₂ Reduced (TON)				
Year : 2014	Measures from non-investment (staff participation)									
	Library Building Chiller Timer	84,000	344,400	61.03	-	-	-	-	-	
	Energy Saving Awareness in lighting	24,090	98,769	17.50	-	-	-	-	-	
	Turn off PC Monitor when not in-use	32,120	131,692	23.34	-	-	-	-	-	
	Turn off Lighting in Staff Zone when not in-use	13,365	54,797	9.71	-	-	-	-	-	
	Time schedule for cleaning conference hall	18,720	76,752	13.60	-	-	-	-	-	
	Remove cooling drinking water tank	23,652	96,973	17.18	-	-	-	-	-	
	Re-wire switch in classroom	25,436	104,288	18.48	-	-	-	-	-	
	Reduce boiler usage in office area	56,064	235,469	40.73	-	-	-	-	-	
	Reduce turn on time for lighting in stadium	8,760	36,792	6.36	-	-	-	-	-	
	Lighting zoning in indoor stadium	30,240	127,008	21.97	-	-	-	-	-	
	Measures from investment									
	Replaced to VRF air-conditioner	303,928	1,276,498	220.81	-	-	-	8,585,000	6.73	
	Replaced to chiller 200 T (auditorium Phase 2)	127,296	521,914	92.48	-	-	-	3,100,000	5.94	
Replaced to chiller 150 T (library)	112,320	471,744	81.60	-	-	-	2,887,980	6.12		
Total for 2014	859,991	3,577,095	624.80	0	0	0	14,572,980	4.07		
Year : 2015	Measures from non-investment (staff participation)									
	Turn off UPS after worktime	28,105	116,917	20.42	-	-	-	-	-	
	Library Building Chiller Timer	81,000	332,100	58.85	-	-	-	-	-	
	Reduce intensity of PC	13,070	54,372	9.50	-	-	-	-	-	

Energy Conservation Activity	Conservation per year						Invest. (THB)	Payback Period (year)
	Electricity			Fuel				
	(kWh)	(THB)	CO ₂ Reduced (TON)	(MJ)	(THB)	CO ₂ Reduced (TON)		
Monitors								
Lighting Timer at University Gate	14,600	60,736	10.61	-	-	-	-	-
Reduce boiler usage in student dormitories	100,740	423,108	73.19	-	-	-	-	-
Turn off Air-conditioners 15 minutes earlier in workdays	40,500	168,480	29.42	-	-	-	-	-
Measures from investment								
Replaced to inverter air-conditioner	184,270	766,563	133.88	-	-	-	7,500,000	9.78
Installed heat Condensing Unit	5,840	24,294	4.24	-	-	-	42,800	1.76
Installed VSD motor at CHP	27,144	112,919	19.72	-	-	-	446,640	3.96
Installed Smart Class Room System	11,753	48,892	8.54	-	-	-	132,400	2.71
Replaced to LED T8	674,983	2,807,929	490.39	-	-	-	4,723,688	1.68
Replaced external lighting to LED	10,512	43,730	7.64	-	-	-	240,108	5.49
Install lighting senser and dimmer	141,662	589,314	102.92	-	-	-	1,108,288	1.88
Installed Chiller Management System	26,053	108,380	18.93	-	-	-	508,250	4.69
Installed solar	2,950	12,272	2.14	-	-	-	249,952	20.37

Energy Conservation Activity	Conservation per year						Invest. (THB)	Payback Period (year)
	Electricity			Fuel				
	(kWh)	(THB)	CO ₂ Reduced (TON)	(MJ)	(THB)	CO ₂ Reduced (TON)		
cell								
Total for 2015	1,363,182	5,760,043	990.37	–	–	–	15,452,126	2.68
Total 3 Year	4,620,724	2,620,434	10,992,408	1,903	0	0	0	34,151,106

Consistency

To encourage staff to participate in energy saving programs, Huachiew Chalermprakiet University has conducted various activities to develop three mains drivers of energy saving, which consist of three distinct wares as follows:

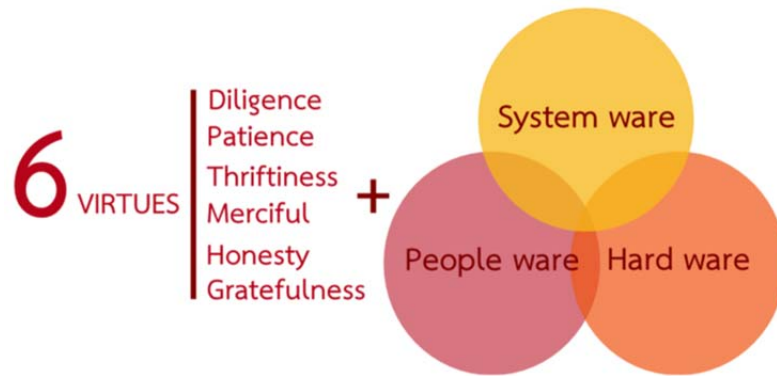

Employee development (Peopleware): This part was developed through annual energy saving training and “6 Virtues” development activities. These six virtues comprised of diligence, patience, thriftiness, merciful, honesty and gratefulness.

System set-up (Systemware): Through staff collaboration, Huachiew Chalermprakiet University has planned to receive ISO50001-Energy management within this year, which has standardized our sustainable energy saving program.

Efficiency (Hardware): Systems were fine-tuned. It will ensure that energy, supplied, is efficiently consumed and machines and systems are correctly maintained. Along these processes, development plans are considered under the criteria of “ROI period of less than three years”



Table 3: Energy Conservation Planning and Activities 2016-2018

No.	Energy Conservation Activities	Period	Annual Energy Conservation Goals					Invest. (THB)	Payback Period (Year)
			Electric			Fuel (LPG)			
			(kW)	(kWh)	(THB)	(kg)	(THB)		
Year : 2016									
1. Employee development (Peopleware)									
1.1	Energy Saving Awareness Training	Jan – May 2016	–	–	–	–	–	500,000	–
1.2	Visit companies with successful energy saving buildings	Mar – May 2016	–	–	–	–	–	200,000	–
2. System set-up (Systemware)									
2.1	Apply ISO 50001 in university	Jan – Aug 2016	–	–	–	–	–	–	–
2.2	Apply for ISO 50001 Certification	Aug – Nov 2016	–	–	–	–	–	300,000	–
2.3	Innovation Contest R2I	Jun – Oct 2016	–	–	–	–	–	50,000	–
3. Efficiency (Hardware)									
3.1	Replaced to inverter air-conditioner (Phase 1)	Jul – Dec 2016	88	234,133	973,993	–	–	6,500,000	6.67

No.	Energy Conservation Activities	Period	Annual Energy Conservation Goals					Invest. (THB)	Payback Period(Year)
			Electric			Fuel (LPG)			
			(kW)	(kWh)	(THB)	(kg)	(THB)		
3.2	Replaced to LED T8 (Phase 1)	Jun – Sep 2016	78	167,400	696,384	–	–	1,000,000	1.44
3.3	Installer Meter (Phase 1)	Apr – Aug 2016	–	–	–	–	–	500,000	–
Year : 2017									
1. Employee development (Peopleware)									
1.1	Energy Saving Awareness Training	Jan – May 2017	–	–	–	–	–	500,000	–
1.2	Visit companies with successful energy saving buildings	Mar – May 2017	–	–	–	–	–	200,000	–
2. System set-up (Systemware)									
2.1	Develop work procedure to comply with Energy Saving Program	Jan – Dec 2017	–	–	–	–	–	–	–
2.2	Study ISO 14001 system	Jan – Dec 2017	–	–	–	–	–	–	–
2.3	Innovation Contest R2I	Jun – Oct 2017	–	–	–	–	–	50,000	–
3. Efficiency (Hardware)									
3.1	Replaced to inverter air-conditioner (Phase 2)	Jul – Dec 2017	88	234,133	973,993	–	–	6,500,000	6.67
3.2	Replaced to LED T8 (Phase 2)	Jun – Sep 2017	47	100,440	417,830	–	–	600,000	1.44
3.3	Installer Meter (Phase 2)	Apr – Aug 2017	–	–	–	–	–	500,000	–
3.4	Install On-grid Solar Cell	Jul – Dec 2017	16	23,360	97,178	–	–	1,000,000	10.29
Year : 2018									
1. Employee development (Peopleware)									
1.1	Energy Saving	Jan –	–	–	–	–	–	500,000	–

No.	Energy Conservation Activities	Period	Annual Energy Conservation Goals					Invest. (THB)	Payback Period(Year)
			Electric			Fuel (LPG)			
			(kW)	(kWh)	(THB)	(kg)	(THB)		
	Awareness Training	May 2018							
1.2	Visit companies with successful energy saving buildings	Mar – May 2018	–	–	–	–	–	200,000	–
2. System set-up (Systemware)									
2.1	Continues development to a Green University	Jan – Jul 2018	–	–	–	–	–	–	–
2.2	Innovation Contest R2I	Jan – Oct 2018	–	–	–	–	–	50,000	–
3. Efficiency (Hardware)									
3.1	Replaced to inverter air-conditioner (Phase 3)	Jul – Dec 2017	88	234,133	973,993	–	–	6,500,000	6.67
3.2	Replaced to LED T8 (Phase 3)	Jun – Sep 2017	18.6	40,176	167,132	–	–	240,000	1.44
3.3	Installer Meter (Phase 3)	Apr – Aug 2017	–	–	–	–	–	500,000	–
Total				1,033,775	4,300,504	–	–	26,390,000	6.14

Performance

Verifiability and Impact

Energy Saving

For over 5 years, Huachiew Chalermprakiet University has continuously been conducting various energy saving projects. Huachiew Chalermprakiet University's Board of Directors also managed 34.15M Baht funding for educating our staffs and students (Peopleware), developing our working systems (Systemware) and replacing old machines with efficient ones (Hardware) to maximize efficiency of our energy

consumption. Due to these developments Huachiew Chalermprakiet University can reduce energy consumption by more than 2,620,434 kWh.

Table 4: University Energy Efficiency Index during 2012-2015

Year	(1) Electricity (kWh/Year)	(2) Fuel (MJ/ Year)	(3) Total Energy Used (MJ/ Year) [(3) = (1)*3.6 + (2)]	(4) Areas (m ²)	(5) Energy Efficiency Index (MJ/m ²) [(5) = (3)/(4)]	Save [%]
2012	7,346,000	–	26,445,600	102,712	257.47	–
2013	6,707,000	–	24,145,200	102,712	235.08	8.70
2014	6,031,000	–	21,711,600	102,712	211.38	17.90
2015	6,269,000	–	22,568,400	108,847	207.34	19.47
Sum.	26,353,000	–	94,870,800	–	–	–
Avg.	6,588,250	–	23,717,700	–	227.82	–

※Remarks: In 2014, due to a re-schedule to comply with AEC, semester term was 4 months longer.

Environmental Effect

- Reduction of CO₂ Emission due to Energy Saving Plans

Since 2011, Huachiew Chalermprakiet University can reduce CO₂ emission by more than 1903 Tons of CO₂ from its total energy consumption. We also launched the “Clean Bicycle Project” which totally replaced motorcycle usage in our campus. The project was initially started with only 100 bicycles, given to Huachiew Chalermprakiet University by our alumni who graduated in that year. Now, there are over 500 bicycles available in every corner of Huachiew Chalermprakiet University’s campus. This project not only reduced CO₂ emission by motorcycles, but also pollution, sound and risks from accidents and crimes in our campus. Huachiew Chalermprakiet University also provided 6 electrical shuttle cars which our staffs and students board from building to building. These cars were named after the six virtues of Huachiew Chalermprakiet University to remind those who use them about what drives our organization.



Clean Bicycle Project

- Waste and Pollution Management

Pollution and waste are by-products of human activities. Having this awareness, Huachiew Chalermprakiet University analyzed our activities to reduce these by-products. One of our achievements was 100% reduction of foam material in our cafeterias and replacing them with degradable ones. From this success, we initiated other activities in Huachiew Chalermprakiet University to reduce the consumption of foam as well. We were also awarded World Class Standard Mass Catering by the Food Institute (WHEN), Department of Industrial Works. This indicated our success in our waste management project, such as personal waste management and bacteria bank which can be used in cleansing processes. Huachiew Chalermprakiet University also aimed to reduce our paper consumption. Starting in 2010, we reduced our paper cost by more than 85.5% or equivalent to 2.3M Baht.



100% Foam Reduction and Decreased Paper Consumption



Changing the university's project to increase green space



Bacteria Bank and Chemical-free Vegetables

Recycling

Huachiew Chalermprakiet University has applied the 3R processes in our waste management. These 3R consist of:

REDUCE– We encouraged our staffs and students to reduce paper consumption through various projects such as applying online system in booking and doing polls, and sharing meeting documents by e-mail instead of the printed-out version.



Reduce the use of paper within the university

REUSE – At Huachiew Chalermprakiet University, our people use both sides of the A4 paper. We also apply “REUSE” concept in other fields such as using left over materials in gardening and watering our plants by water from the canal in the campus.



Reuse Project within the University

RECYCLE – We have performed waste management in order to recycle our wastes into different kinds of usable materials and develop those wastes to become products. By doing so, we can reduce some of our material costs.



Recycling program within the University

Completeness

Success in energy saving was not made by a single person, but by collaboration and the efforts of all staff of Huachiew Chalermprakiet University. We owe our

success to the teamwork and active education/training of our staff and students, which have eventually created a culture of energy saving at all levels of University operations.



Benefits

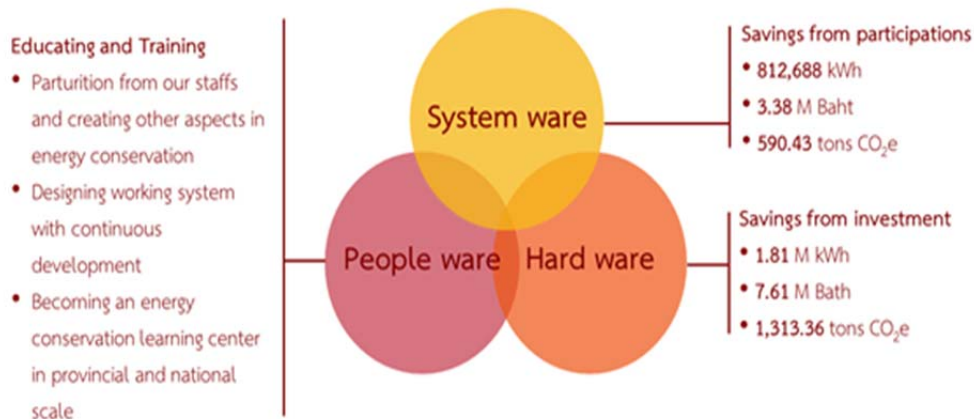

Save Energy (2.62 M kWh), Save Cost (10.99 M Baht), Reduce CO₂ (1,903.79 tons CO₂e)

An immediate benefit was the saving of 2,620,435 kWh in energy consumptions, which was equal to 1,903.79 tons of CO₂. This translated into a substantial financial savings of 10,990,409 baht. However, the most valuable long-term benefit has been the opportunity to inspire staff at all levels to adopt energy saving as their own campaign. This resulted in creativity at the individual and team levels that did not

only increase daily energy saving, but also enhanced life quality for our personnel and students. We are ready to share what we learned and support other organizations on their journey to sustainable energy success. At Huachiew Chalermprakiet University, we are honored to contribute to Thailand's green initiatives. Our ultimate goal is to play our part to conserve energy and make the world a better place for the benefit of the next generation.

-See more at:

<http://esci-ksp.org/project/energy-conservation-virtue-at-huachiew-chalermprakiet-university/>



Energy Conservation Virtue at Huachiew Chalermprakiet University, Thailand



Assoc. Prof. Prachak Poomvises
President Huachiew Chalermprakiet University



“May you manage the university along the path of righteousness.”



ENERGY CONSERVATION VIRTUE



STRATEGY

6 VIRTUES

- Diligence
- Patience
- Thriftiness
- Merciful
- Honesty
- Gratefulness

+

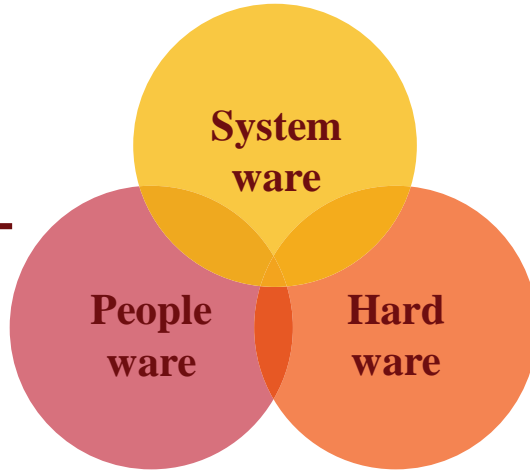

=



=

Step 8. Systematic review and analysis

Step 7. Monitoring energy management systems assessment.



Organization of Energy Management

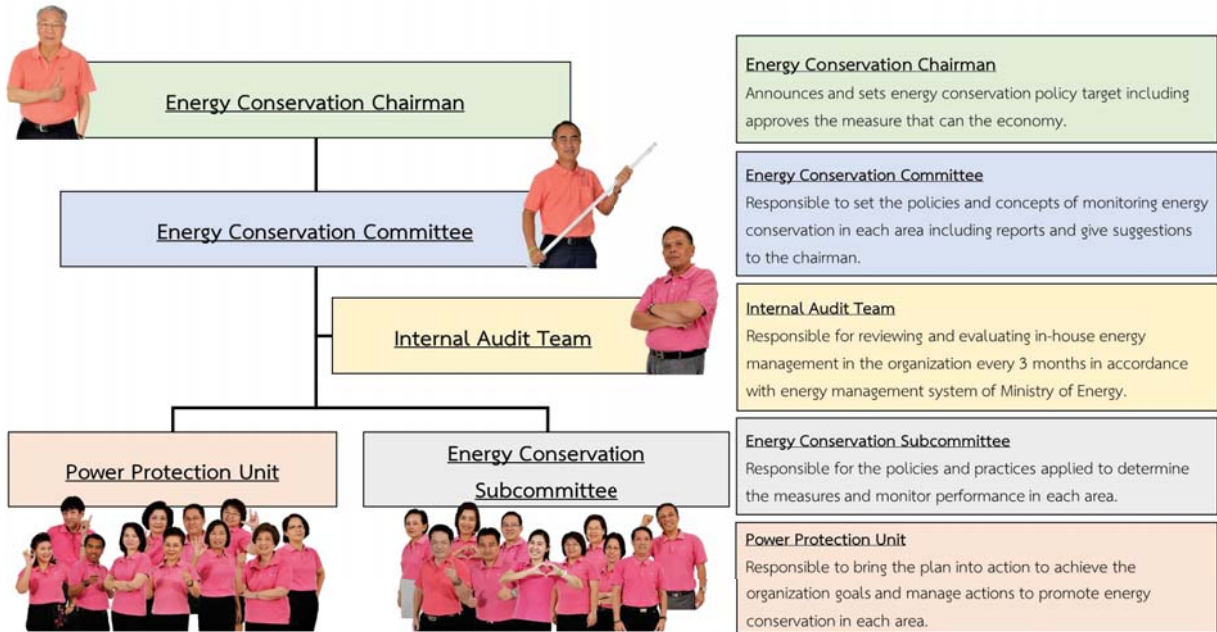

Targeting 5-year energy conservation plan

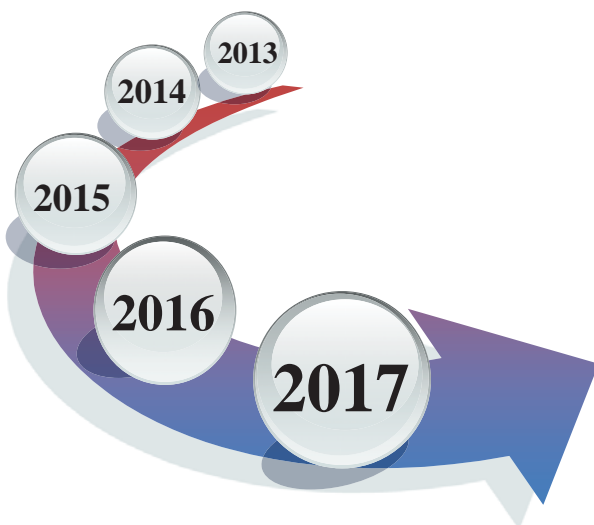

2013 - 2014

- Reducing 10 % of our energy consumption

2015 - 2017

- Reducing 15 % of our consumption 2012
- Becoming a role model university in virtuous energy conservation
- Becoming a notional and ASEAN role model energy saving university

People ware = Attitude, Knowledge, Skills + Participate

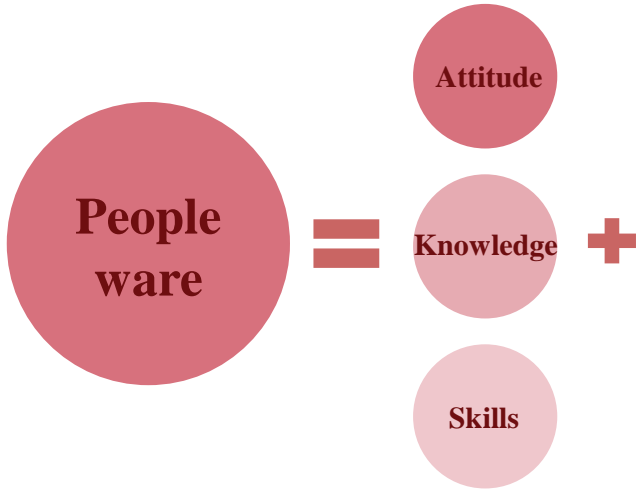

Leader

Personnel

Student

Leader must be examples

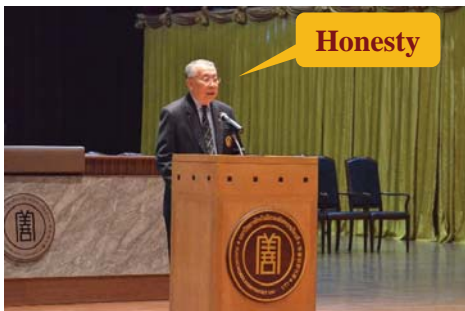

Employee Development and Educational Training

Expert advice to success



Phayathai Sriraja Hospital

Share success



Ayutthaya Hospital

Study from role model



King Mongkut's University

Finding secret of achievement



Richmond Hotel

Analyse case studies



Phayathai 2 Hospital



Develop teamwork



Energy Saving of Chalermprakiet Building

The White Bicycle Project



 Distance 3 km 

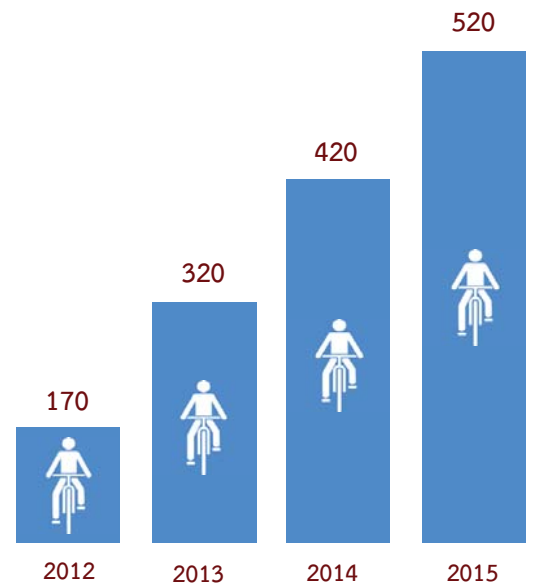



**500
motorcycle**

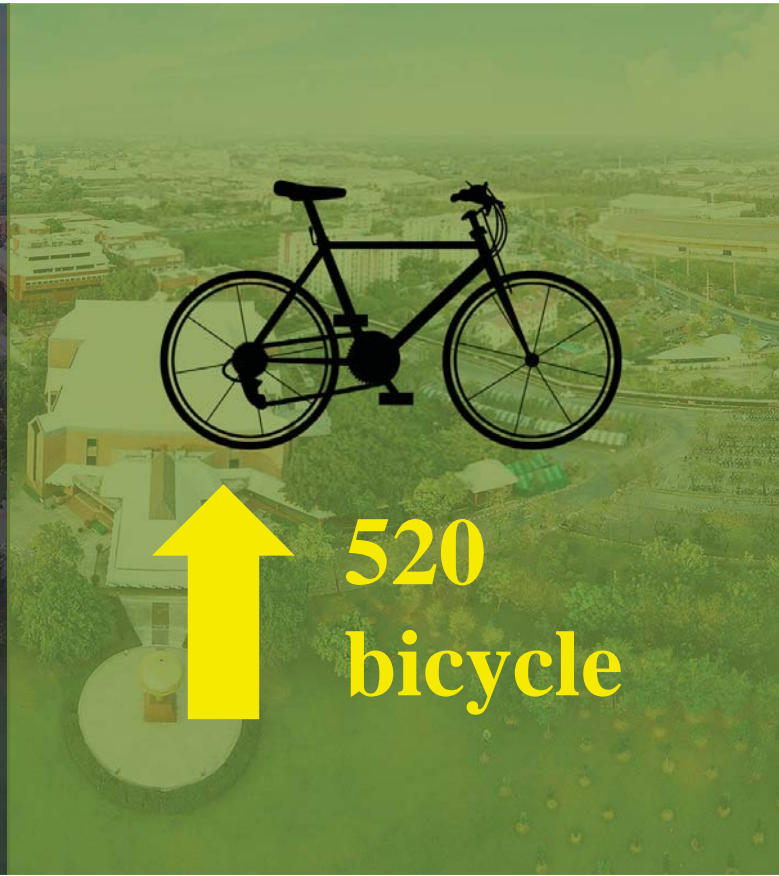

**520
bicycle**



**500
motorcycle**

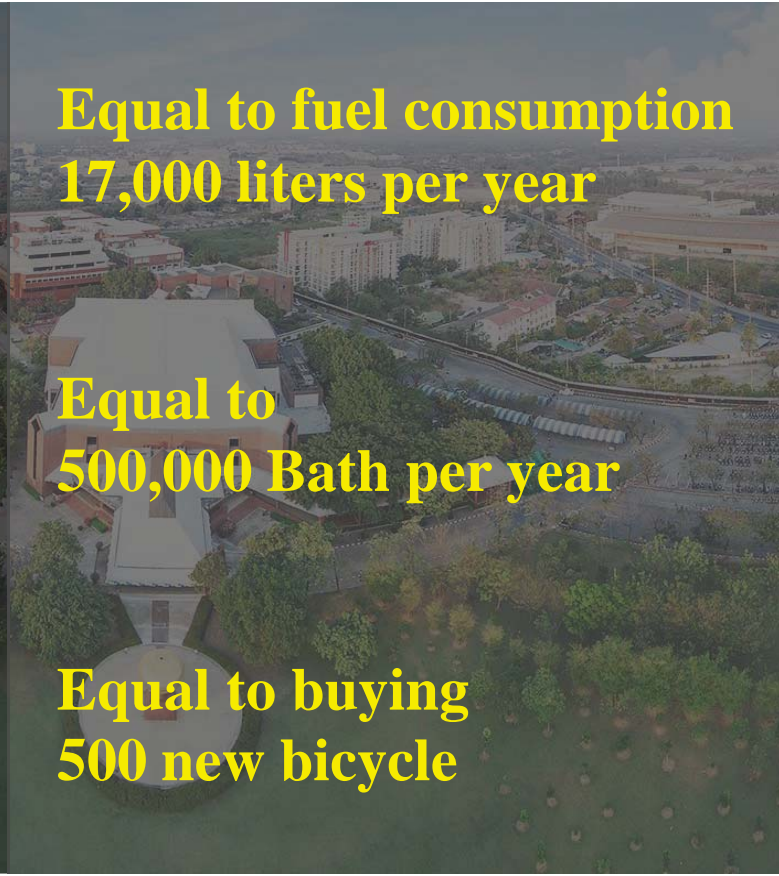

**Equal to fuel consumption
17,000 liters per year**

**Equal to
500,000 Bath per year**

**Equal to buying
500 new bicycle**

Air pollution
Noise pollution
Use Fuel
Accident

Safe
Atmosphere
Healthy
Conscious mind
Participate
Apportion
Save

Add green space to the campus



Leader

Personnel

Student



2017 (Present)



2007 (Past)



2012



2017

Walking energy campaign “Contribute to the collective”



Campaign to promote wearing a helmet.



The campus electric bus project



The liquor store project around campus.

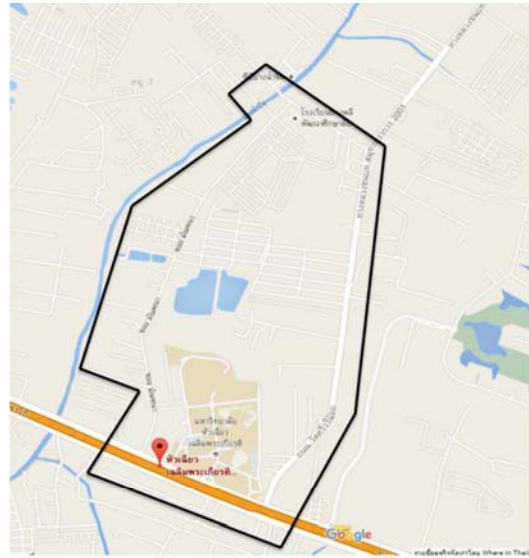

Non-Smoking Area Campaign

**A cigarette factory
Use more than
60,000 MWh a year.**

Remark : Data from CENDID ENERGY SOLUTION COMPANY

Green Bus station and definition Project



reduce temperature

Add oxygen

Energy saving

Chemical free Vegetable Project



100% Foam Reduction and Decrease Paper Consumption

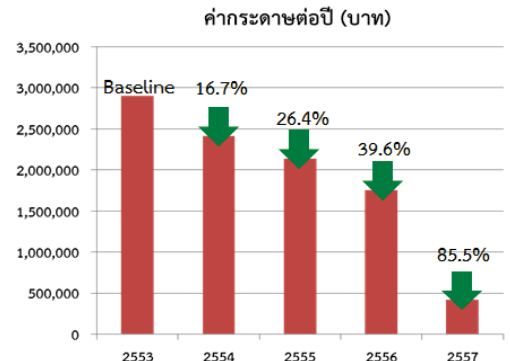

Hard ware

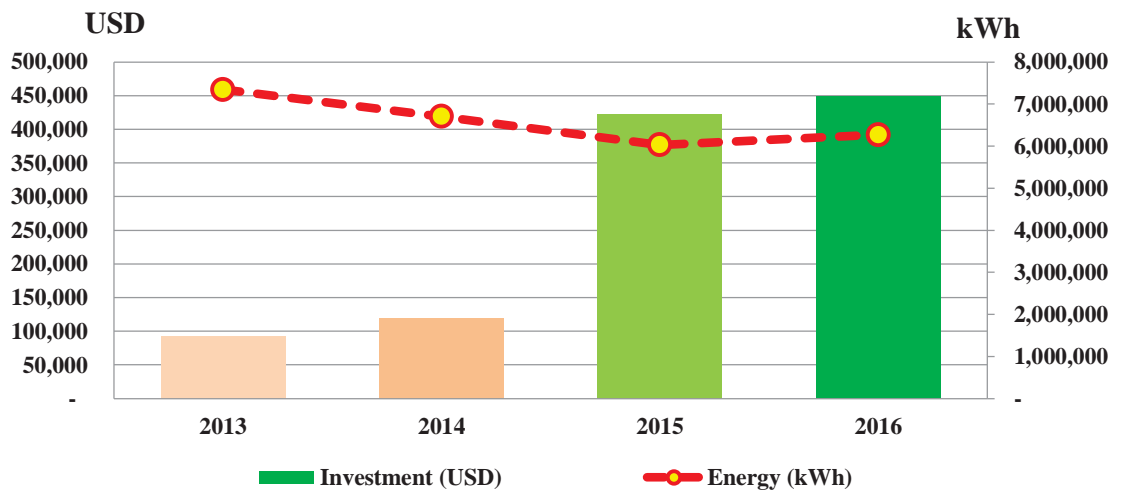

Measures investments in 2013-2015



Example: Replaced to chiller high efficiency



Saving

- Electricity 127,296 kWh/year
- Electric bill 521,914 Baht/year
or 15,168 USD/year

Investment 3,100,000 Baht
or 90,090 USD

Return on Investment in 5.94 year

Remark : 1 USD = 34.41 Baht

Example: Replaced to LED



Remark : 1 USD = 34.41 Baht

Saving

- Electricity 674,983 kWh/year
- Electric bill 2,807,929 Baht/year
or 81,602 USD/year

Investment 4,723,688 Baht
or 137,277 USD

Return on Investment in 1.68 year

Energy Consumption from 2013 - 2016

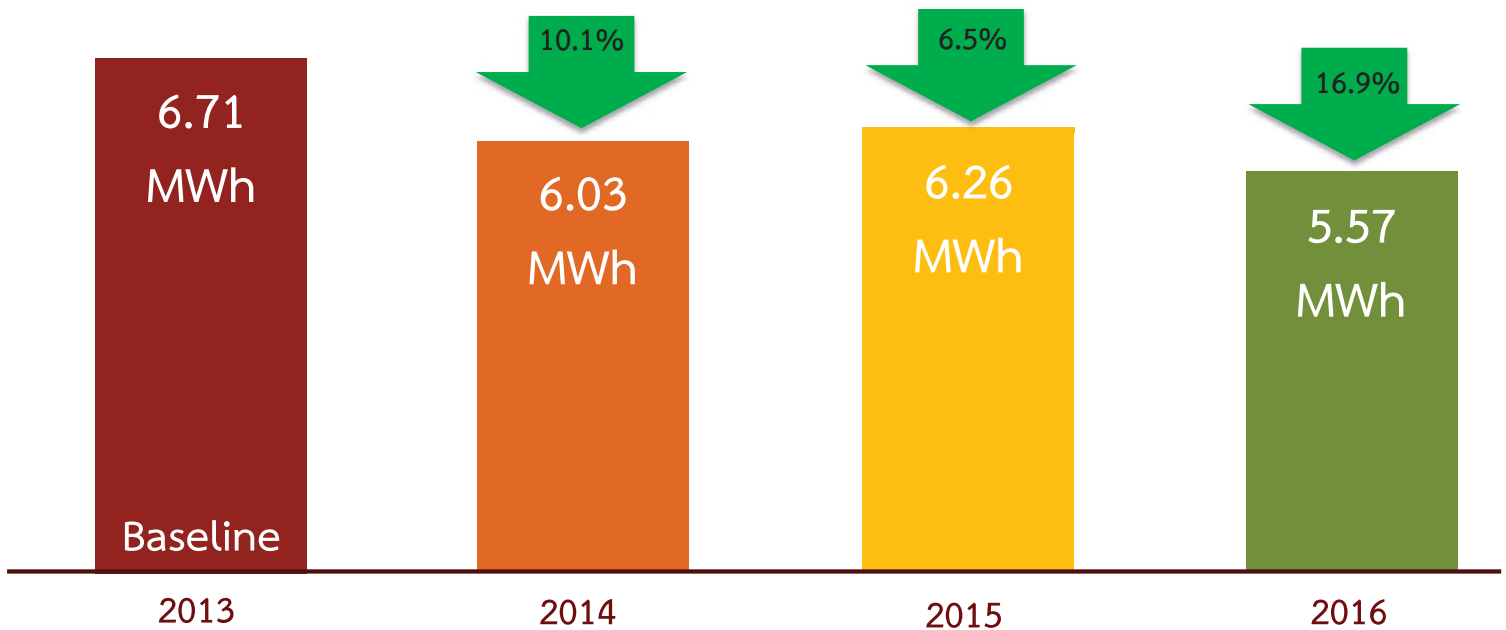

Energy Efficiency Index 2013 - 2016

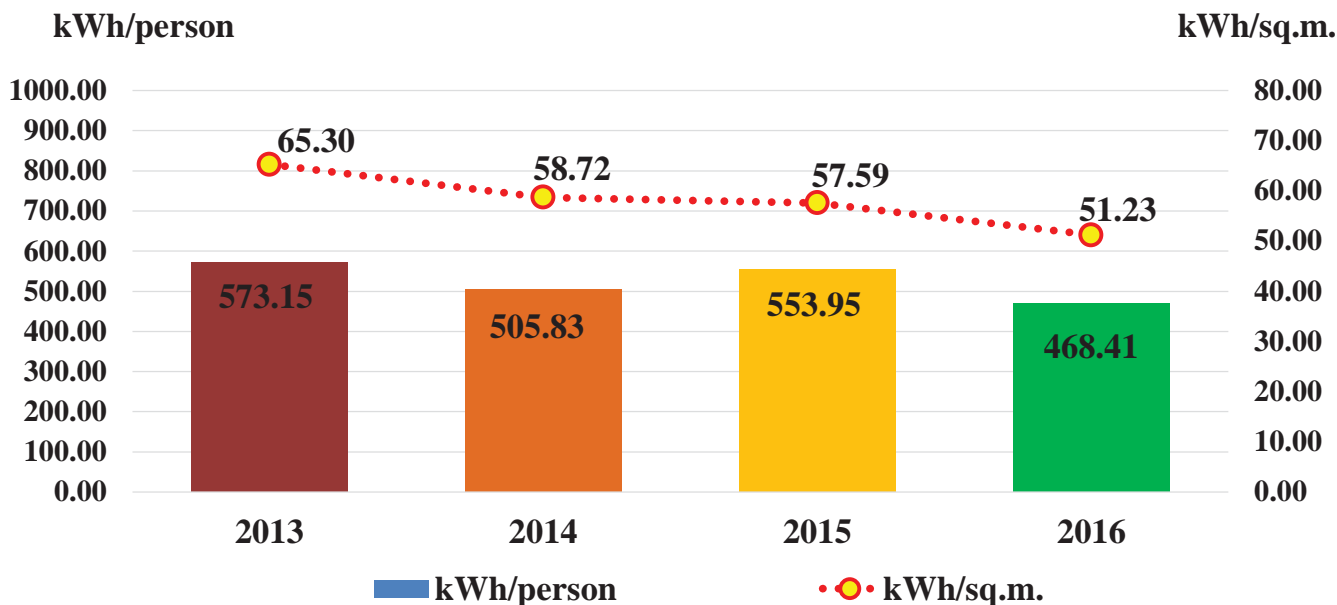

Results from Energy Conservation Program 2013-2016

Educating and Training

- Parturition from our staffs and creating other aspects in energy conservation
- Designing working system with continuous development
- Becoming an energy conservation learning center in provincial and economy scale

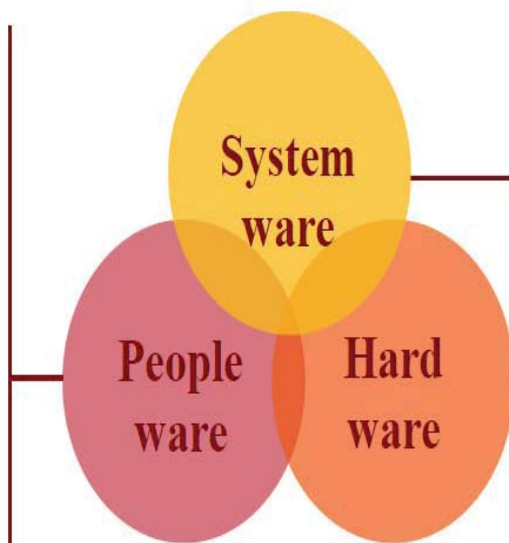

Savings from participations

- 812,688 kWh
- 3.38 M Baht or 98,204 USD
- 590.43 tons CO₂e

Savings from investment

- 1.81 M kWh
- 7.61 M Bath or 221,250 USD
- 1,313.36 tons CO₂e

Remark : 1 USD = 34.41 Baht



Save Energy **2.62** Million kWh/4Year



Reduce CO₂ **1,904** Ton CO₂e/4Year



Save Cost **10.99** Million Baht/4Year
or **319,453** USD/4Year

Remark : 1 USD = 34.41 Baht

HCU Energy & Environment Map





มหาวิทยาลัย
หัวเฉียวเฉลิมพระเกียรติ
华侨崇圣大学 Huachiew Chalermprakiet University

**We will do this university well.
By saving energy with virtue.**



Smart Grids

**Penghu Dongjiyu Microgrid
Small Power Supply System**

(Silver)

Special Assistant **Joseph, C.D Chang**

Chairman Office, Chung-Hsin Electric & Machinery MFG. CORP

(2014-2017)

Director of Taiwan Smart Grid Industry Association (2013-2017)



➤ **Academic Qualifications**

Air Force Institute of Technology, Electronics Engineering

➤ **Related Experiences**

1. Process Automation and Computer Integration Manufacturing at Sugar Refinery of Taiwan Sugar Corporation, Kaoshiung
2. The Fifth of Power Distribution Automation Planning-Feeder Automation, TaiPower Company.
3. The Sixth of Power Transmission Automation Planning-Sub-station Automation Establishment.
4. SCADA System of Switch Yard at Dar-tan Thermal Power Plant, TaiPower Company, Guanying.
5. DDCS Back-up System Implementation at Taoyuan and Miaoli DDCC
6. Joint Development of Microgrid Power Management System with INER.

➤ **Professional Awards**

Golden Quality Medal Award granted by “Public Construction Commission” recently including:

The 5th annual award (2004) ;

The 7th annual award (2006) ;

The 8th annual award (2007) ;

The 9th annual award (2008) ;

The 11th annual award (2010) ;

The 12th annual award (2011) ;

The 16th annual award (2016)

➤ **Contact Information**

Contact Email: tw003039@chem.com.tw

Telephone : +886 3 328 4170 ext 2124

See more at

<http://www.chem.com.tw/products/hundred-kilo-watt-smart-micro-grid-system-for-isl-and?lang=en>

Penghu Dongjiyu Microgrid Small Power Supply System

Chinese Taipei

Managing Organization: Chung-Hsin Electric & Machinery Manufacturing Corporation



Strategy:

Chinese Taipei is surrounded by off-islands that require self-generating power supply. However, power instability, black-outs and high level of carbon emission have been the issues for these islands and waiting for better solution. Limited choices such as diesel generator (DG) or other isolated power supply units are used because of small-sized power system or the distance to better-equipped power provider. Meanwhile, the carbon emission from diesel generator or other independent power supply is also bring uncertainties and concerns not only because of the pollution but also the inefficiency of high cost from fuel transporting over long distance. Therefore, the importance of increasing the usage of renewable energy can't be more emphasized. It reduces the fuel use, cuts down the carbon emission significantly and eases the burden from budget limits. To optimize the overall efficiency for even better quality in power supply and to further enhance the power stability, the integration of micro-grid technology comes in and works as the solution. As it works as the foundation, it extends the application for renewable energy and trims down the overall cost even more. Reliability, stability, high quality and financial sustainability all come in one

place for future development and improvement for electricity supply for off-islands.

Innovativeness

Penghu County Government plans “*Carbon-Free Island Demonstration Project - Planning and Designing.*” The goal is to introduce the micro-grid system in Dongjiyu. The objectives include, increasing the use of renewable energy, reducing diesel power generation, enhancing the quality of power supply in off- islands and providing low-carbon power supply. *The Project* includes the use of power generation forecasting for energy scheduling, remote monitoring for load forecasting, and control system for three-phase equilibrium of AC power.

The Origin of This Innovative Technology

Power generation by renewable energy is dependent on weather, seasonal and day/night conditions, therefore, energy storage and back-up power are needed to stabilize power supply for microgrid in islands or remote regions. Meanwhile, due to the inherent intermittency of renewable energy, the power quality is inevitably affected when increased amount of renewable sources are connected to the grid, this means a real-time monitoring, control system and energy storage are therefore required to effectively dispatch and coordinate the distributed energy sources. The overall economic effectiveness of microgrid is critical to end-user market and wide adoption, accordingly, optimization of resource usage and provision of high quality power are important topics for microgrid development.

Proposed Technology

This application is specifically targeted to address the four microgrid issues – supply stability, power quality, economic effectiveness, and increased utilization and penetration of grid-tie renewable-based generation. Our team proposes a total solution, including microgrid design and evaluation, Smart microgrid Monitoring and Energy Management System (“**Smart μ -MEMS**”), the integration of Energy Storage System

(ESS) and existing diesel engine power generator as a Hybrid Microgrid Solution (“Hybrid MS”).

The microgrid evaluation optimizes both sub-system and system configuration and operation requirements based on analysis from environmental and actual grid conditions. This covers the complete life-cycles of the renewable generation sources, other distributed generation and the energy storage solution deployed. **Smart μ -MEMS** effectively controls the scheduling of different renewable energy, other generations and energy storage systems by matching the needs of end-users. Based on real-time system operating status and information, coupled with requirements on power supply stability and power quality, **Smart μ -MEMS** optimizes resource allocation – both for regular use and emergency conditions. **Hybrid MS**, characterized by the combined Energy Storage System (ESS) and diesel generator, improves the power quality issues arising from high renewable energy penetration, PV power supply disruption or feeder lines congestion in urbanized settings.

Chung-Hsin Electric & Machinery Manufacturing Corporation (CHEM) has implemented the microgrid system project in conjunction with the Penghu County Government in Dongjiyu and implemented the project “Penghu Dongjiyu Microgrid Small Power Supply System (PDMS).” **Hybrid MS** is the core technology of the project. The framework of PDMS is as following:

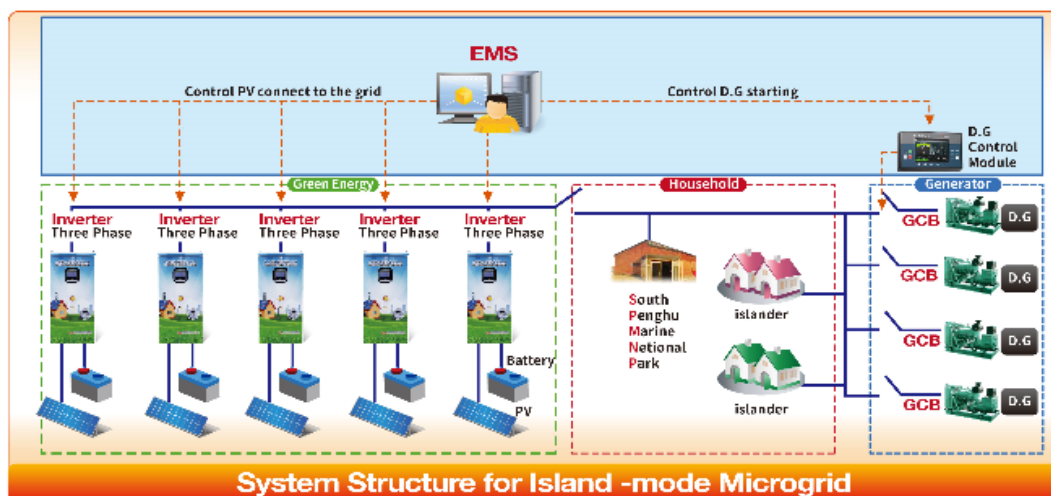

Fig. 1 - The Framework of PDMS

Financial support and public-private partnership

Hybrid MS is the core technology of the project. The advantages are significant. The higher usage of renewable energy reduces the consumption of diesel fuel along with exhaust emission, especially CO₂. By cutting down the consumption of diesel fuel, it saves up to 48% of the cost not only for diesel generators operating but maintenance (diesel cost, delivery and maintenance charges). Meanwhile, high quality and stability of off-island electricity supply is then greatly enhanced via **Smart μ-MEMS**. For the moment, financial support and potential investors are keen to explore more possibilities because of the positive outcome generated from utilizing Hybrid MS. This is to say that financial investment along with the government's focus on smart low-carbon power generating system, have transferred into steady and high quality electricity use for local residents. A win-win situation for the investors, business operator, government and the residence is therefore guaranteed.

Inspiration of Later or Subsequent cases

The project PDMS is currently part of the county's low-carbon project. PDMS integrates with the existing diesel power-generating system for regular daily power usage and it effectively facilitates the solution on high cost-reduction on diesel power supply. PDMS also serves as independent electricity provider for domestic use needed from damages caused by climate changes.

Rural village, off-islands or rural none-grid terrain could extensively utilize renewable energy based on local environmental conditions to reduce CO₂ and other greenhouse gases and the dependence on fossil fuels. This project promotes the concept of "Smart-generating, Smart-storage and Smart-feeding."

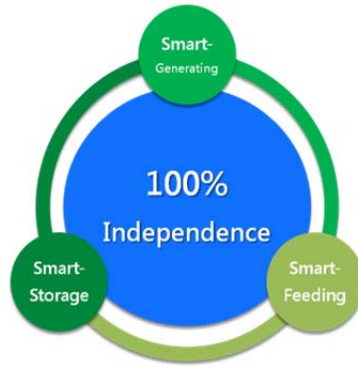

Fig. 2 - Smart-generating, Smart-storage and Smart-feeding

The Domain Knowledge Enlightened by this Policy

There are three main direct potential application of our proposed system for adoptions in Chinese Taipei’s grid, as shown in Fig. 3. For each potential application, the PDMS will provide performance data points and the associated economic feasibility aspects that cater to Chinese Taipei’s domestic needs, as illustrated clearly in table 1.

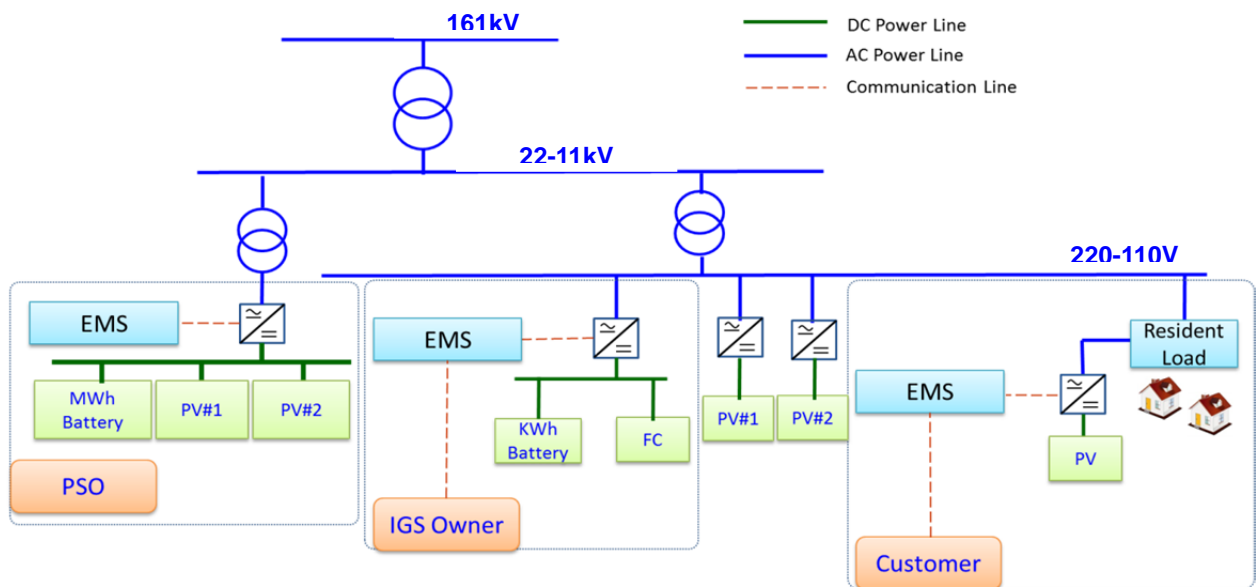

Fig. 3 - Three Main Direct Potential Applications for Adoptions in Chinese Taipei’s Grid

Table 1 - Three Application Scenarios

Three Application Scenarios	Direct User	Technology Areas	Economic Parameters
1. Direct connection to feeder-lines	Power System Operator (PSO)	System Specification for feeder line voltage control; Communication protocols	Cost and economic feasibility for corresponding auxiliary services offered
2. Direct couple to existing solar system	Intermittent Generation Sources (IGS) Owner	Response time; Accurate control	Operational cost and economic attractiveness in Chinese Taipei's adoption
3. Direct connection on user's end (Distribution)	Customer	System operational stability	Cost comparison with grid-supplied electricity in Chinese Taipei

Scenarios:

1. Direct grid connection (e.g. feeder-lines):

With the expected increasing in both the quantity and distribution of Intermittent Generation Sources (IGS) in Chinese Taipei, the Power System Operator (PSO) will need to enact comprehensive control schemes to manage the intermittent nature of such sources since the security and reliability of the power system is not compromised. Specifically, the associated specification requirement on the communication protocols and direct local voltage control are key technology application areas of interest.

2. Integrate via specific set-point of Intermittent Generation Sources/Aggregator:

The aggregated power output of all IGS from renewable sources like solar energy could be potentially modeled and treated as one pseudo generator, for the purpose of assigning regulation and spinning reserves costs. With controllable power output enabled by the hybrid microgrid technologies, coupled with Demand Response Mechanism, this can help further open up IGS players for direct participation of electricity market. The parameterization of response timing and coordination and control mechanisms are key technology application areas of interest, which will be verified and investigated through our PDMS.

3.Direct integration on end-users' end:

The proposed system can be readily integrated on end-users' ends (e.g. commercial and industrial facilities) and effectively increase the renewable power utilization and on-site distributed generation capacities, once the system operational stability is thoroughly established and gains market credence.

Transparent channel of public communication

CHEM is willing to share with APEC members in this successful experience. Currently, the information of PDMS is available via TSGIA (Taiwan Smart Grid Industry Association) and the operating data and needed information is also provided to INER (Institute of Nuclear Energy Research) for long-term information collection and research.

The project implementation results have been published in "The Development of Smart Grid Industry and Technology in Chinese Taipei 2016" by Taiwan Smart Grid Industry Association. Up until now, the system improvement is in on-going process, Penghu County Government will be later recommended to disclose the information on benefits and effectiveness along with facts and figures via online resource or the county's websites.

The Policy

Using **Smart μ -MEMS** and the integration of Energy Storage System has increased the proportion of renewable energy sources and this satisfies the "Policy for Nuclear-Free Homelands" from Chinese Taipei government. The detail is as below,

Table 2 - New Energy Policy of Chinese Taipei Government

Spread Item	Targets in Year 2025	
	Capacity (MW)	Power Generation (G.kWh)
Hydro Power	2,500	5.5
Wind Power		
Onshore Wind Power Plant	12,000	3.0
Offshore Wind Power Plant	3,000	10.0
Solar Power Plant	20,000	20.0
Geothermal power generation	600	3.5
Biomass energy generation	1,200	8.0
Total	28,500	50.0
Estimated investment in construction costs	Approx. USD 89 Billion	
Total Power Generation in Chinese Taipei	53,691	270.1
The proportion of renewable energy	53.1%	18.5%

Measure:

Power generation by renewable energy is dependent on weather, seasonal and day/night conditions, therefore, energy storage and back-up power are needed to stabilize power supply for microgrid in islands or remote regions. Meanwhile, due to the inherent intermittency of renewable energy, the power quality is inevitably affected when increased amount of renewable sources are connected to the grid, this means a real-time monitoring, control system and energy storage are therefore required to effectively dispatch and coordinate the distributed energy sources. The overall economic effectiveness of microgrid is critical to end-user market and wide adoption, accordingly, optimization of resource usage and provision of high quality power are important topics for microgrid development.

Practicability

Diesel generators are used in most of inhabited islands out from limited choices. Meanwhile, it has presented obstacles in power capacity and stability for development in tourism opportunities and management in a long run. Soon, optimization on solar

energy, wind energy and other renewable energy recourses and forming diesel generating as the supporting role in combination in micro-grid will gradually reduce the dependence on diesel or other import fuels. This proactively facilitates the use of green energy, reduces the consumption or waste of fossil fuels, and lessens the greenhouse gas emission (for example, CO₂) for the future goal of “*Low-Carbon Island*” with our advantages in “*Smart-generating, Smart-storage and Smart-feeding.*”

Phase I - Effective measure

Technology of DG and Solar Hybrid System and Intelligent Microgrid Control and Smart Energy Management are designed and adopted for a smarter micro-grid with less environment impact and better life quality for domestic needs.

“Technology of DG and Solar Hybrid System”

1. This technology is to make DG (diesel generator), which serves as conventional choice for power supply, work as the base power supply, and to use it to integrate the benefits of the PV power system with ESS. This satisfies the domestic power needs from residents and increases the usage of renewable energy while reducing high cost in diesel usage and going further for the goal of low-carbon power supply.
2. Operating cost drops to 50% of the cost from the conventional choice as using solar energy effectively cuts down the high cost in diesel or other fuel supplement.
3. Power supply quality and stability are further strengthened because of the optimized power system, which includes the benefits from integration of smart micro-grid and the conventional choices.

“Intelligent Microgrid Control and Smart Energy Management”

1. Smart Energy Management System (SEMS) works as the platform of integration for information flow, data, power usage and live status from

Inverter, MPPT and batteries. The management system uploads the data for power used and generated to cloud system for remote controlling.

2. SEMS manages power based on power source and power generation day and night. In daytime, it controls ESS to store the solar energy and manages the output via Inverter over microgrid for day-time usage. At times when the solar energy source is limited, SEMS continues to manage and allocate the power usage based on night-time needs.

Phase II - Effective measure

“Power SCADA System”

1. The Power SCADA System collects current PDMS information, calculates the information according to the updated information from users and generates the strategies of resource allocation for short, medium and long term goal. By the optimized strategy of resource allocation with the robust calculating result, the automation of scheduling and controlling of PDMS's power generation and energy storage surely reduces the waste of fuel or diesel and effectively lowers the cost in DG's operating and maintenance.
2. In order to provide continuous power supply (for Marine National Park Headquarters), diesel generators are planned to be used for primary and daily power usage. Solar energy and batteries for energy storage are allocated to be back-up power supply. Automatic Transfer Switches (ATS) operates automatically and switches to solar energy and batteries for power supply when diesel generators are stopped. While this situation occurs, the back-up power supply system takes over the power load to sustain the reliability of power supply.

Numerical Goal for Reference

1. Maximum penetration rate of solar energy > 80%
2. Average daily penetration rate of solar energy > 40%
3. Operation costs reduction > 48%

Replicability for International Use

Penghu County's support and our team's investment in this project will enhance the current power quality, and improve the operation performance for PDMS. In the short-run, as the economic benefits of PV and energy storage technology improve, the operational experience of PDMS can be expanded and transplanted to specific off-grid and environmentally protected areas in South East Asia, as well as other areas to improve the distributed energy systems' efficiencies. In the long run, further technology development around these key areas would effectively enable higher integration of solar and other distributed power generation into needs. The strategic collaboration between Chinese Taipei enterprises and institutes would help develop microgrid-based total solution for the region, bolstering Chinese Taipei as a center of excellence for high value-add microgrid system design and engineering domestically as well as the emerging-Asia markets.

Responsible organization

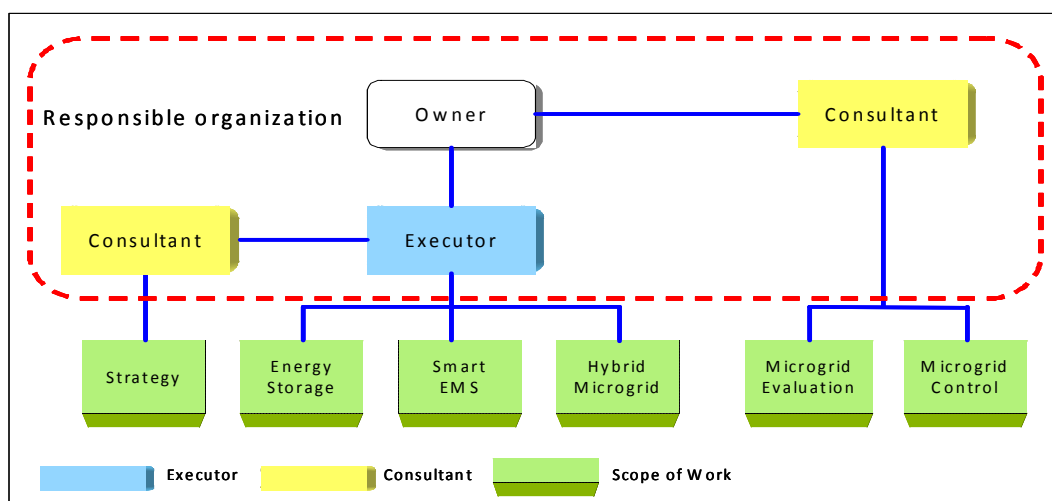

Fig. 4 - Responsible organization

Cost-Effectiveness

The parameters and results of the 20-year average cost of this system are shown in uploaded file "Appendix 1-1 Levelized Cost of Electricity (LCOE).pdf." The cost details include the equipment cost, the construction cost, the fixed annual expense and the equipment replacement that has reached the end of the service life. The formula for calculating the Levelized Cost of Electricity (LCOE) is:

$$LCOE = (\text{Sum of Present Value of Annual Expenditure}) / (\text{Sum of Product of Solar Power Generation and Discount Factor})$$

According to the above-mentioned calculation results, LCOE of Dongjiyu Solar Power System with Energy Storage System is USD 0.1826 / kWh, as shown in uploaded file "Appendix 1-1 Levelized Cost of Electricity (LCOE).pdf."

Reduction of Carbon Emission

The locations of measured points are shown in Fig. 5. (a) 4 power meters are used to measure 4-loop power supply of the diesel generator set. (b) 3 power meters are used to measure 3-loop power usage of electricity by villagers (c) 5 power meters are used to measure power generation of 5 sets of solar power systems. On the island, the main power source comes from diesel generators and solar power system. Therefore, increasing the supply of green energy is then able to reduce the power output of diesel generators and carbon emission generated by DGs. Statistical green energy output and reduced carbon emission can be quantified as follow:

$$\begin{aligned} \text{Reduced Carbon Emission} &= \text{green energy output (kWh / year)} * 0.528 \text{ (kg-CO}_2\text{ / kWh)} \\ &= 109,581 \text{ (kWh / year)} * 0.528 \text{ (kg-CO}_2\text{ / kWh)} \\ &= 57,859 \text{ (kg-CO}_2\text{ / Year)} \end{aligned}$$

Carbon emission: 0.528 kg-CO₂ / kWh (Cited in Bureau of Energy, Ministry of Economic Affairs.)

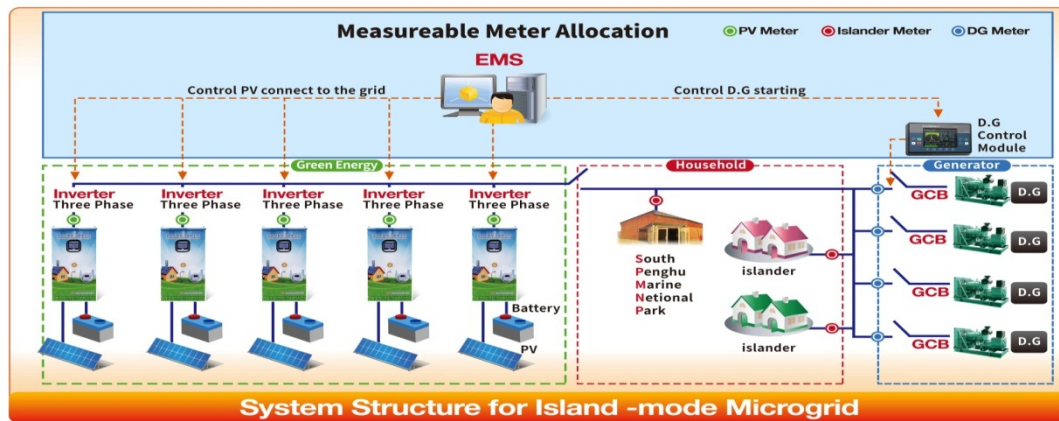

Fig. 5 - Meter Allocation

Consistency with Energy Policy and Strategy

To promote further growth of renewable energy-related development efforts in sustainability, Chinese Taipei government has already enacted aggressive policies and initiatives to scale-up its PV generation targets, with the Ministry of Economic Affairs, Bureau of Energy (MOEA-BOE) commissioned plan to scale-up the PV capacity installation from 615.2MWp in 2014 to 20GWp in 2025. To address the issues arising from intermittency of solar power generation, MOEA-BOE has already proposed the strengthening measures to manage such intermittent generation sources, and plans to increase the grid's tolerance and capacity for increased intermittent generation sources through the use of grid-tie energy storage.

Our project goal is in accordance with the goal of Chinese Taipei energy policy.

1. Energy generating: the project promotes penetration rate of solar energy by the way of building an island-type microgrid of high proportion of renewable energy sources.
2. Energy storage: the project expands the power storage for photovoltaic power generation with SEMS; it increases the penetration rate of renewable energy, and reduces power generation cost by power scheduling.

3. Smart system integration: PDMS consists of renewable energy full-day power forecasting program, full-day load forecasting program, generator and energy storage unit optimization scheduling program, scheduling & real-time control program to achieve the goal of low-carbon energy dispatching for Dongjiyu. PDMS covers forecasting, scheduling and energy allocation. The project starts from low-carbon energy plan and power supply system development, aims to integrate the island's existing diesel generators and 86.4kWp solar power generation system.
4. Cost reduction: The project aids to ease the problem of high cost in power generation and to help the island becomes a demonstration site for low-carbon power generation.

Implementing organization

The team of this project is comprised of notable enterprises and institutes in Chinese Taipei, including TIER, INER, CHEM and others. The microgrid evaluation and microgrid smart control algorithm, developed by INER, will be used for system testing and impact evaluation, while CHEM and supporting vendors will lead the development and integration of hardware equipment for **SMART μ -MEMS** and **Hybrid MS**.

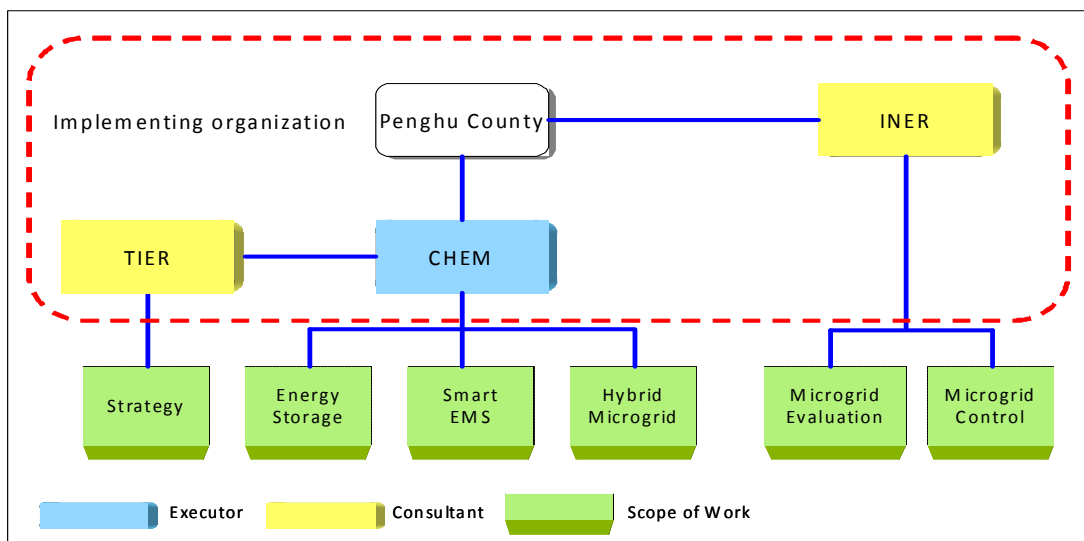

Fig. 6 - Implementing organization

All of the participating organizations have committed resources and express strong interest to support technology development and qualification efforts on validating and further business case of microgrid growth in the Asia Pacific region. Below is a brief profile summary of the implementing organizations, while detailed info on these organizations will be given in uploaded file “Appendix 2 Team member CV.pdf”.

1. Penghu County:

Penghu County's permanent establishment is responsible for promoting the use of renewable energy sources in similar, inhabited off-islands, such as Wangan, Qimei, Tongpan, Hujin, etc. These include the total of nineteen inhabited off-islands.

2. Chung-Hsin Electric and Machinery Manufacturing Corp. (CHEM):

Founded in 1956, CHEM is an established industry player serving the power sector with a strong yearly revenue of USD 3 billion. CHEM's core products range from Gas Insulated Switchgears (GIS), AMI Meter, Smart Grid equipment to associated commissioning systems. CHEM started investing in new energy areas since 2008, and has completed notable product milestones including 5kW methanol-based fuel cell, smart inverter, hybrid DC/AC microgrid and smart microgrid Energy Management System (EMS).

CHEM is committed to further its technology development in microgrid, and aims to enhance and further such technical exchange through international collaboration partners. It is envisioned that through the participation of PDMS, CHEM will assist in further co-development of an internationally certified microgrid solution that is suited for Chinese Taipei and Asian countries.

3. The Institute of Nuclear Energy Research (INER):

The Institute of Nuclear Energy Research (INER), established in 1968, is a government agency with a history of credibly safeguarding dedicated to the research

and development (R&D) on nuclear safety, nuclear facility decommissioning, radioactive waste treatment and disposal technologies. Moreover, INER also bears the mission of developing radiopharmaceuticals for the public well-being. Nowadays, Chinese Taipei's energy policies are ensuring nuclear safety and waste reduction, building up green energy and a low carbon environment, and working eventually toward creating a nuclear-free homeland. In conformity with the Chinese Taipei energy policy, INER has expanded its researches in recent years to including the development of green energies such as new and renewable energies, energy conservation and carbon emission reduction, in addition to participating in the energy-related economic policy research. Its expertise conventional generation, transmission and distribution, smart grids, and sustainable energy use, as well as energy markets and regulations.

4. Taiwan Institute of Economic Research (TIER):

Taiwan Institute of Economic Research (TIER) was established on September 1, 1976 as the first private independent think tank in Chinese Taipei, whose main purpose is to actively engage in research on domestic and foreign macroeconomics and industrial economics to promote Chinese Taipei's economic development. Division 1 of TIER is currently commissioned by Ministry of Science and Technology to conduct new energy technology strategy's overall efficiency evaluation, and is also commissioned by the Bureau of Standards, Metrology & Inspection. to conduct specific feasibility study of testing and certification of smart grid program and international cooperation programs.

Performance:

The combination of diesel generators and smart micro-grid will not only improve the power quality and stability, but also enhance the penetration ratio of renewable energy resources by introducing the automatic controlling function. Significant

Completeness

The existing power generation system on Dongjiyu is composed of 4 diesel generators, namely 3 sets of 200 kW and 1 set of 300 kW, with the total installed capacity of 900 kW, and 86.4 kWp PV system. The annual power generation of PV system is evaluated according to the investment parameters, as shown in the uploaded file “Appendix 1-2 Investment Parameters.pdf.”

The PV module area is 1.63m²; the maximum power of PV system is 86.4kWp with 85.71% of performance ratio (PR); the PV module efficiency is 15.4%. On the other side, Dongjiyu’s average annual amount of insolation from 2007 to 2014 is approximately 1476.6kWh/m². These mean the annual power generation of PV system in Dongjiyu shall reach 109,582.6 kWh as the annual power generation per PV module goes to approximately 317.08 kWh.

Measurable Achievement Scale

In most of scenarios, lead-acid batteries are recommended to be set up to complete the system arrangement. The recommended Depth of Discharge (D.O.D.) of lead-acid batteries is 50% to avoid shorter life time of the batteries caused by frequent over-discharging.

The formula for calculating annual power generation of 86.4kWp PV system is:

Annual power generation of PV system

*= (Module Quantity) * (Annual Power Generation per Module)*

*= 345.6 * 317.08 (kWh)*

= 109,582.6 (kWh)

As shown in uploaded file “Appendix 1-2 Investment Parameters.pdf”, annual power generation of 86.4kWp PV system is about 109,582.6 kWh.

Achievement

The proposed project of PDMS (<http://esci-ksp.org/project/penghu-dongjiyu-microgrid-small-power-supply-system/>), aims to achieve the following KPIs for quality and effectiveness:

1. To design the system model and complete the associated analysis via Microgrid Evaluator to achieve an optimized parameterization for **Smart μ -MEMS**.
2. To develop and implement the proposed **Smart μ -MEMS**, which provides the use of power generation forecasting for energy scheduling, remote monitoring for load forecasting, and control system for three-phase equilibrium of AC power to aim at lowering the operation cost of Dongjiyu microgrid system.
3. To develop and implement the proposed Hybrid MS to mitigate the intermittency of PV generation.
4. To achieve power generation for 300 kWh each day within 12 months, with the new generation cost below USD\$0.1826/kWh.
5. To improve current microgrid system stability, e.g. maintaining voltage levels within 0.99%-1.01%.
6. To reduce greenhouse gas emissions by 57.86 metric tons/year.

Verifiability

According to the micro-grid operation data collected and recorded so far from Donjiyu Monitoring System, the data covers two main parts. Firstly, on power generation and consumption, the data indicates solar energy generation, green energy output from grid-tied inverters, energy generated from diesel generators and also, power consumption from residents over the island respectively. Secondly, it also reveals the percentage of domestic power usage for local residents from green energy

and diesel generator. Green energy takes up to 40% of daily usage while 60% of daily usage comes from power generation of diesel generators. See the figures below.

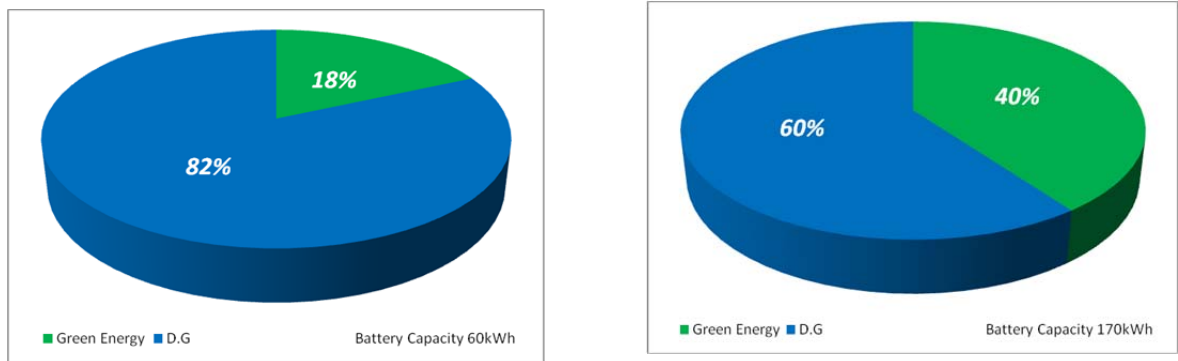

before

after

Fig. 7 - The Penetration Ratio of Green Energy for 60kWh/170kWh Battery Capacity

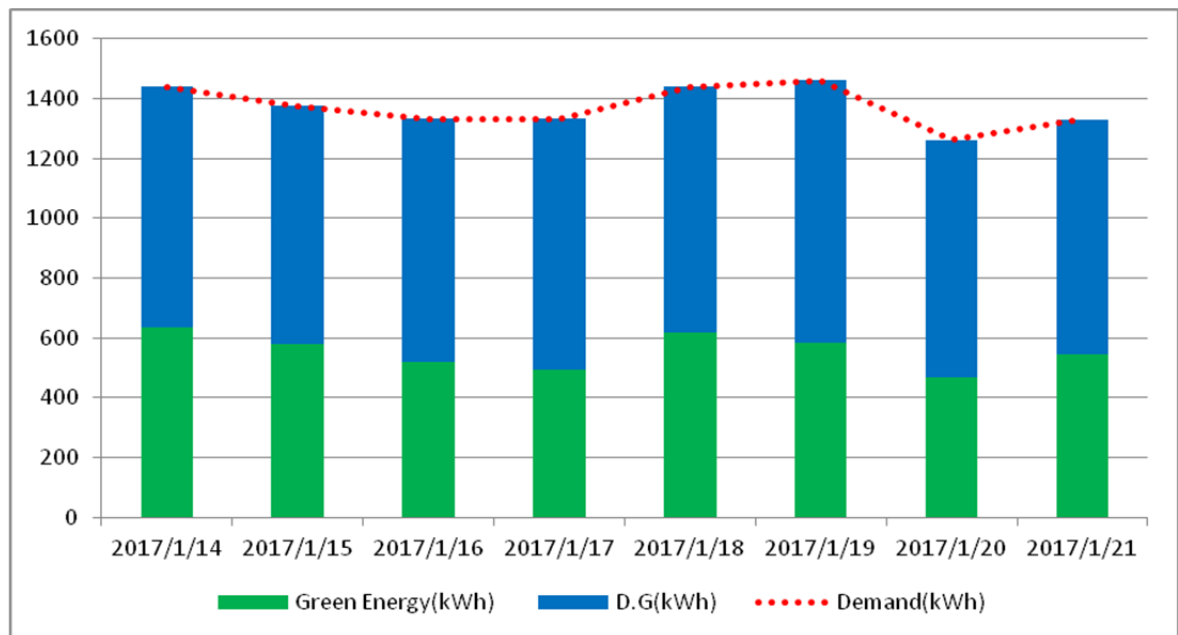

Fig. 8 - Weekly Data of Power Supply/Electricity Usage

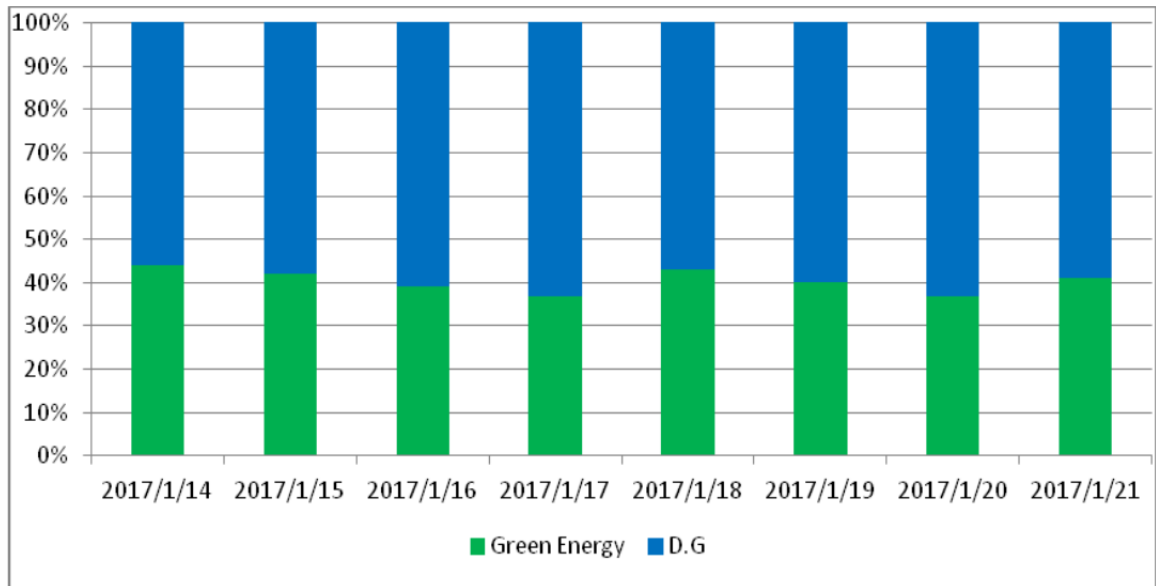

Fig. 9 - Percentage of Power Usage from Green Energy and Diesel Generator

Impact

The key driver for development of smart grid comes from the maturing energy storage technologies. The rapid declining cost of ESS is set to render and boost up the commercial readiness of massive adoption for renewable energy application and integration. Assuming similar microgrid integration schemes as PDMS can be applied in Chinese Taipei main grid system, it could potentially boost up the Intermittent Generation Sources (IGS) capacity from 4.07GW to 28.5GW, as calculated with an overall generational capacity increasing of 24.43GW in year 2025. This domestic source of clean energy of 50 G.kWh amounts to an effective NTD 2.85 Trillion market-sized industry. This is essentially an effective boost for domestic GDP. Given Chinese Taipei's current huge reliance on import of energy for power generation, this can also further strengthen Chinese Taipei's energy security. Moreover, the corresponding environmental impact decreasing offered by this domestic clean energy is also significant.

Multiple Operational Areas for Application

● Off-Grid Mode	● Grid-tied Mode	● Mini Power Station
<ul style="list-style-type: none">➔ Rural areas➔ No utility➔ Islands➔ Diesel fuel is expensive➔ Maintenance free➔ Larger PV and battery	<ul style="list-style-type: none">➔ Urban areas➔ Utility available/unstable➔ High electricity price➔ Interactive with grid➔ Grid feed-in (optional)➔ Smaller PV and battery	<ul style="list-style-type: none">➔ Tele-communication station➔ No utility➔ Good power quality required➔ Diesel generator standby➔ Minimum maintenance➔ Larger PV and battery



Fig. 10 - Multiple Operational Areas for Application

-See more at:

<http://esci-ksp.org/project/penghu-dongjiyu-microgrid-small-power-supply-system/>



2017 Energy Smart Communities Initiative (ESCI) Best Practices Awards Program

Penghu Dongjiyu Microgrid Enhancement – Stability, Quality and Economic Effectiveness



Penghu County Government



Institute of Nuclear Energy Research (INER)



CHUNG-HSIN Electric & Machinery Mfg. Corp. (CHEM)

Outline

➤ Dongjiyu, the off-island

- Past & Present
- Location / Importance

➤ Overview of the project

- Objective
- Motivation
- Approach
- Achievement
- Application
- Suggestion for Upgrade
- Lithium Battery & Fuel Cell
- Hybrid ES reference in S.A

DONGJIYU – The location

- Dongjiyu, connecting Mainland China and Southern Part of Chinese Taipei, brings the important value in 1900s.

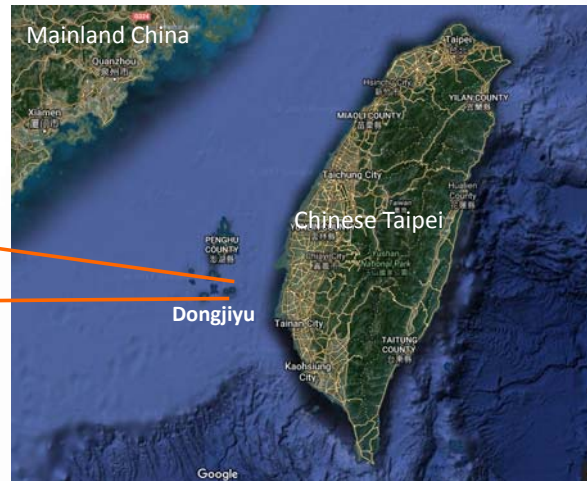

2017 Energy Smart Communities Initiative(ESCI) Best Practices Awards Program : <Pengu Dongjiyu Microgrid Enhancement – Stability, Quality and Economic Effectiveness.>

PAST - Importance

- 100 YEARS AGO as LITTLE SHANGHAI



Photo courtesy: DaAi TV

2017 Energy Smart Communities Initiative(ESCI) Best Practices Awards Program : <Pengu Dongjiyu Microgrid Enhancement – Stability, Quality and Economic Effectiveness.>

PRESENT - Importance

➤ The 9th South Penghu Marine National Park

- 6 endemic plant species
- 18 protected wild species, including 3 endemic species
- The unique location & the important breeding area.



Photo courtesy: South Penghu Marine National Park

2017 Energy Smart Communities Initiative(ESCI) Best Practices Awards Program : <Penghu Dongjiyu Microgrid Enhancement – Stability, Quality and Economic Effectiveness.>

 Chung Hsin Electric & Machinery Mfg. Corp

4

PAST & PRESENT

➤ PAST

- Limited Solution: Diesel Generator as SMALL POWER SUPPLY SYSTEM
- Pollution in Noise, Air, High Opex



➤ PRESENT

- Goal: clean energy for the nature
 - natural resources optimized
 - fuel consumption reduced
 - operating cost reduced



2017 Energy Smart Communities Initiative(ESCI) Best Practices Awards Program : <Penghu Dongjiyu Microgrid Enhancement – Stability, Quality and Economic Effectiveness.>

 Chung Hsin Electric & Machinery Mfg. Corp

5

OVERVIEW

➤ Chung-Hsin Electric & Machinery Mfg. Corp. (CHEM) & the project

- CHEM completed the grid connection project of Dongjiyu's 85kWp photovoltaic and D.G systems.
- Communication Interface: Direct RS-485 for Phase I Monitoring System and Phase II Smart u-MEMS, Wireless Communication for Auto Meter Reader on DC and AC Panel and Power SCADA.

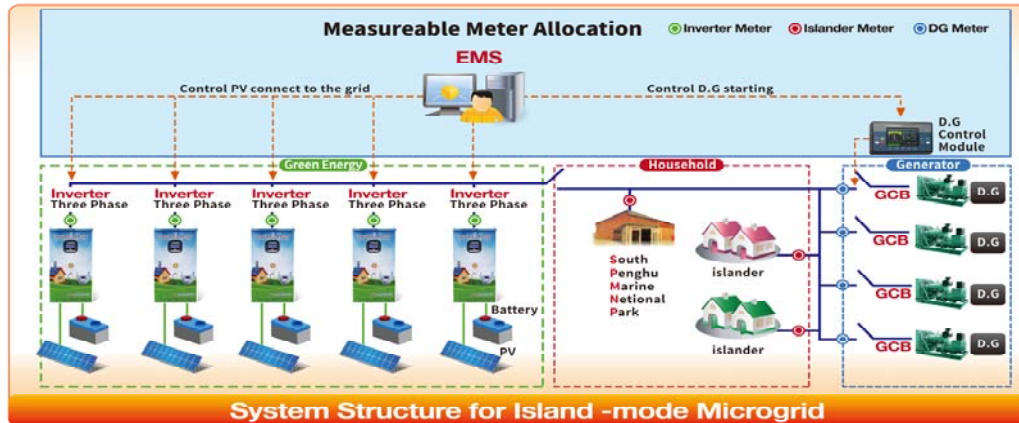

MOTIVATION & OBJECTIVES

Problems/Issues to Address	Overall Project Objectives	Significance and Relevance to Chinese Taipei
Renewable intermittency assessment and control on a micro-grid	To perform impact assessment of intermittent energy sources on the quality of electricity supply from a micro-grid standpoint and specific measures for improvement	Assisted in Penghu County Government enhancement solutions for bettering grid's tolerance and capacity for increased intermittent generation sources through the use of grid-tie energy storage
Emerging microgrid component and algorithmic technologies (e.g. energy storage technologies) performances and their associated deployment configurations	Dongjiyu hybridized system and component performances, conditions and their associated deployment configurations by collecting year-long operational field-data	The project team lead in developing an internationally verified microgrid solution that is suited for Chinese Taipei and Asia countries, and effectively lift up Chinese Taipei's strategic positioning in the global energy industry development

APPROACH & METHODOLOGY

Existing Limitations	Improvement/Enhancement	μ -E	S- μ MEMS	S-ES
Diesel generator needs to be in standby status as ancillary generation for load variation and photovoltaic intermittency.	<ul style="list-style-type: none"> Storage Switching, & Economic Dispatching, achieve Greater flexibility in system design and operation Extended life-time of overall system & lower operational cost 		✓	✓
Power quality issues (e.g. reduced power factor due to current system control mode on diesel generator)	<ul style="list-style-type: none"> Improved on forecasting, scheduling, generating capabilities Shorter response time for storage and can accommodate varying load profiles with flexible output range. 		✓	✓
System instability risks (e.g. Fault of DC bus, battery, PV panel, or generator)	<ul style="list-style-type: none"> Improved overall system data analysis, real-time power quality information, online system transient analysis, accurate and reliable communication system, and high efficiency power conditional equipment 	✓	✓	✓

APPROACH & METHODOLOGY

Flowchart of the Microgrid evaluation

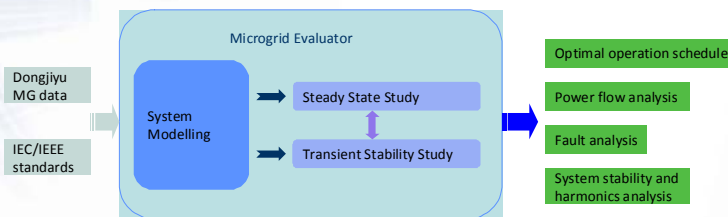

Microgrid evaluation aims to develop a comprehensive microgrid model, which is used to analyse the systematic power flow, fault currents, transients, harmonics, and the overall system operational economics.

Flowchart of the Smart μ -MEMS



Smart μ -MEMS aims to achieve advanced optimized resource allocation, while delivering overall enhancement in system reliability and quality.

APPROACH & METHODOLOGY

- Use of lead acid batteries - higher availability & technology acceptance, cost effective
- Smart ES solution - To improve controlling for fuel efficiency on inverters and batteries

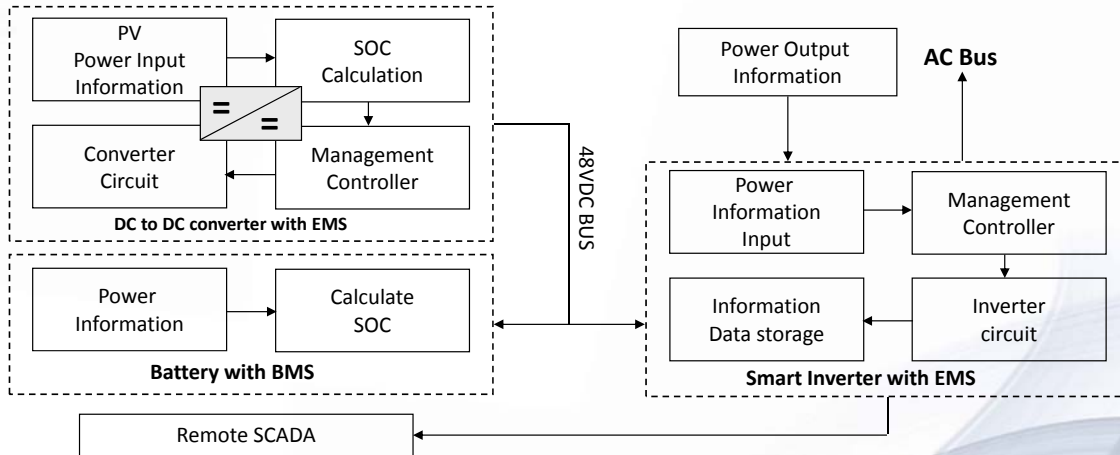

Flowchart of the Smart ES

PENETRATION RATE

- Penetration rate of solar power increased from 17% up to 40%,
- Battery capacity increased from 60kWh to 180 kWh

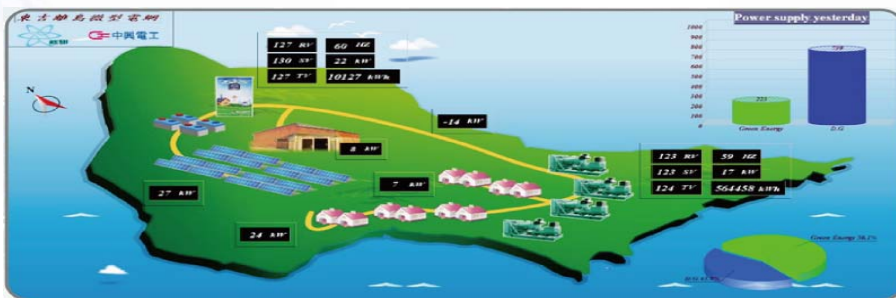

The Monitoring Figure of Dongjiyu Microgrid

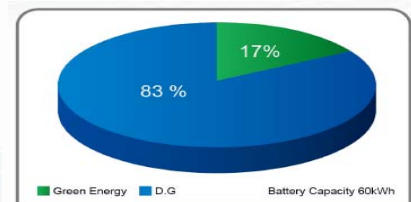

Before improvement

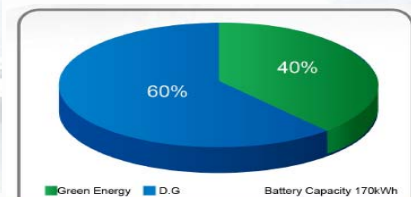

After improvement

ACHIEVEMENT

Key power network & integration characteristics

- Maximum penetration rate of solar energy > 80%
- Average daily penetration rate of solar energy > 40%
- **Operation costs reduction > 48%**
- Generation cost below USD 0.18/kWh

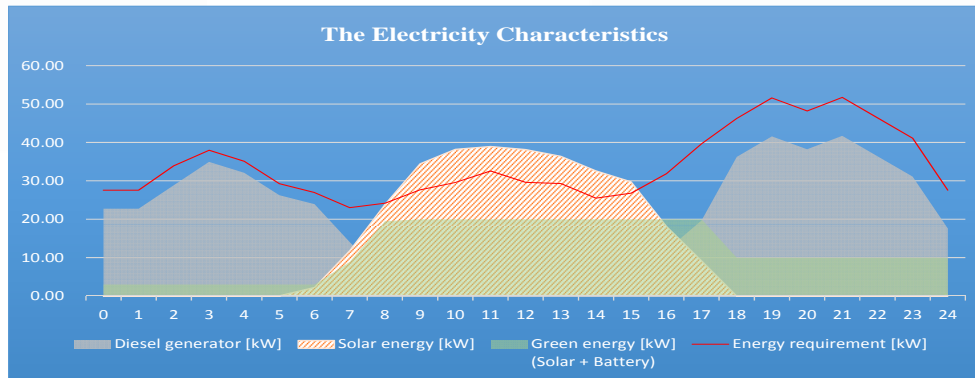

2017 Energy Smart Communities Initiative(ESCI) Best Practices Awards Program : <Penghu Dongjiyu Microgrid Enhancement – Stability, Quality and Economic Effectiveness.>

APPLICATIONS

- Economic Benefits
- Innovative technology
- Environmental Benefits
- Energy Security

Application Scenarios

1. Direct connection to feeder-lines
2. Direct couple to existing solar system
3. Direct connection on user's end (distribution)

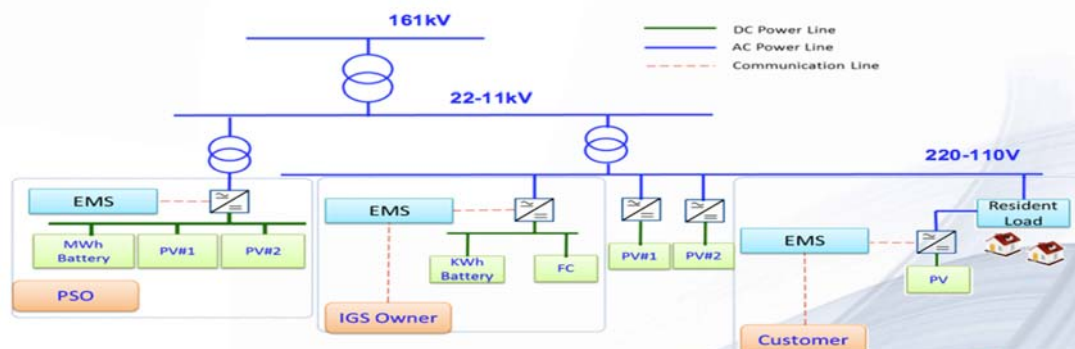

2017 Energy Smart Communities Initiative(ESCI) Best Practices Awards Program : <Penghu Dongjiyu Microgrid Enhancement – Stability, Quality and Economic Effectiveness.>

MULTIPLE OPERATING AREA

- Microgrid is a localized grouping of electricity sources and loads that are operated and connected to the traditional centralized electric grid. Disconnecting and functioning autonomously are also possible for different physical and/or economic conditions.
- It provides the solution for emergency power supplying with flexibility between islanded mode and grid-tied mode.
- Control and protection are big challenges in this type of network configuration, which is generally treated as a hierarchical control.

● Off-Grid Mode	● Grid-tied Mode	● Mini Power Station
➤ Rural areas	➤ Urban areas	➤ Tele-communication station
➤ No utility	➤ Utility available/unstable	➤ No utility
➤ Islands	➤ High electricity price	➤ Good power quality required
➤ Diesel fuel is expensive	➤ Interactive with grid	➤ Diesel generator standby
➤ Maintenance free	➤ Grid feed-in (optional)	➤ Minimum maintenance
➤ Larger PV and battery	➤ Smaller PV and battery	➤ Larger PV and battery

FUTURE UPGRADES

- **Hybrid ES solution** - characterized by the combined fast response of lithium battery and long stable power supply of methanol fuel cells,
- Improves the overall supply stability and power quality issues (i.e. arising from high renewable energy penetration).

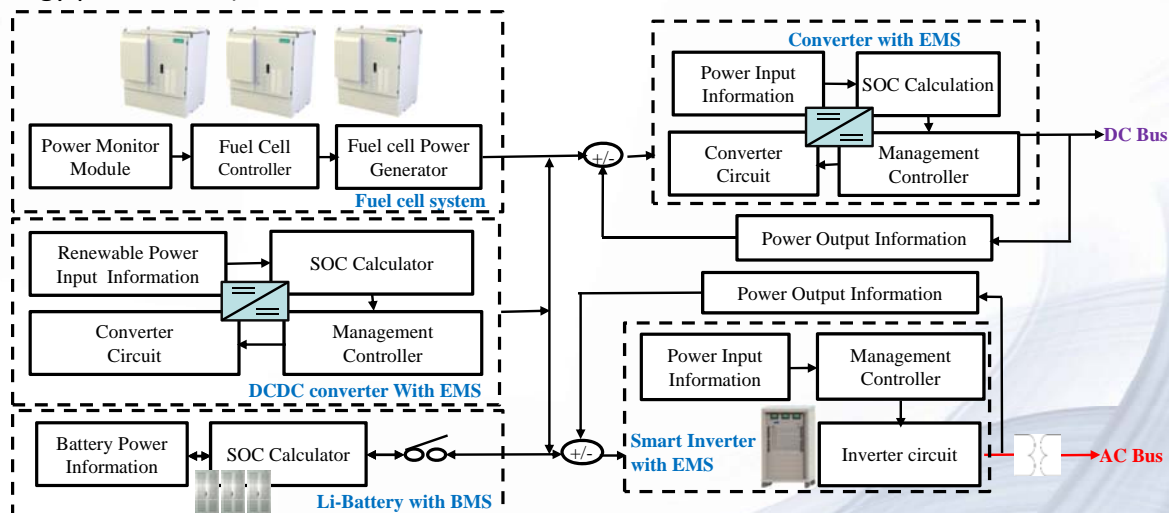

HYBRID ES SOLUTION IN S.A.

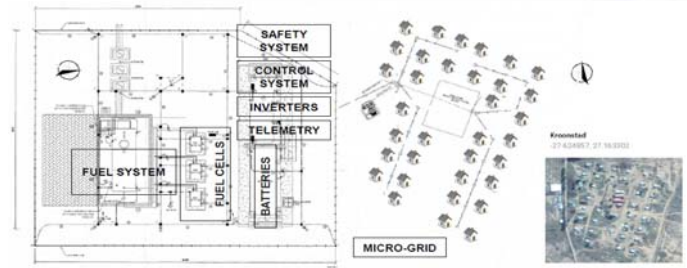
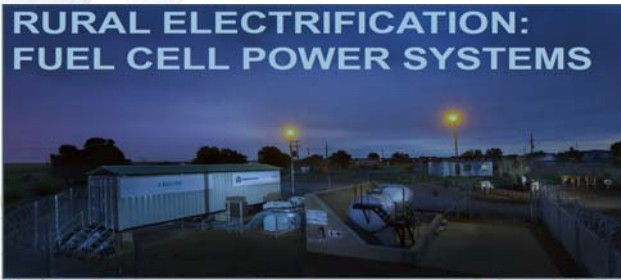

Successful operation since Aug. 2014!



Three 5kW Methanol FC systems

batteries, DC/AC inverters,
fuel system, control system,
telemetry system and
safety system



Sufficient for everyday use

generates 230V,
50Hz AC quality power
at 200kWh per day.
(peak power 60kVA) .)



Easy access to real time data

remote monitoring,
programmed maintenance,
fault detection and correction,
fuel level monitoring and
remotely scheduled deliveries

Smart Jobs and Consumers

**BCA-MOE Back to School
Programme**

(Gold)



NG SIAN CHING

EXECUTIVE MANAGER

Office: +65 6804 4683

Email: ng_sian_ching@bca.gov.sg

EXPERIENCE

EXECUTIVE MANAGER

Jul 2015 - Present

Building and Construction Authority

Graduated with a degree in Environmental Engineering, her passion to drive sustainability led her to pursue a career in the Building and Construction Authority. She was involved in the review, development and administration of green building policies and initiatives, particularly for the public sector and schools in Singapore. She believed that the best way to drive behavioural change for environmental sustainability is through effective education since young. Hence, she invests additional time to guide students, in hope that it would trigger a ripple effect.

EDUCATION

NATIONAL UNIVERSITY OF SINGAPORE

Aug 2011 – Jul 2015

Bachelor of Environmental Engineering (Hons)

During her course of study, she was active within the student community. She was elected as the **Deputy Director of External Relations** of NUS Environmental Science and Engineering Students' Club (2011-2012) and thereafter, promoted to **Vice Chairperson (External)** in the subsequent year. With her outgoing personality and passion to serve, she was also nominated as the NUS Faculty of Engineering Class Ambassador and Class Representative for her cohort.

SKILLS & QUALIFICATIONS



Certified Green Mark Facilities Manager



BCA-MOE Back to School Programme

Singapore

Managing Organization: Singapore Building and Construction Authority (BCA)

How is the material administered: Live Teacher Required



Strategy

The Back to School Programme is a meaningful platform to further the green movement by getting alumni of schools to do their part for their alma mater. These students would help the school attain BCA Green Mark certification and enhance its environmental sustainability programme.

The Back to School Programme is part of BCA's initiative to enhance student engagement and education in environmental sustainability that aims to groom the next generation of green collar workforce in the following ways:

1. Entice-Entice students and schools to come on-board this green building journey, as well as to embark on green building careers through structured internship and mentorship programmes led by BCA officers.
2. Employ-Provide students with a platform to employ technical knowledge related to the built environment and management skills learned in school.

3. Envoy -Get students to be envoys and vehicles to spread sustainability messages.

The BCA Back to School Programme was formally launched in September 2016. Following its' launch, the programme has officially be extended to students from other Institutes of Higher Learning and BCA is on its way to extend the programme to interested industry partner to volunteer as mentors for these students. The target is for all mainstream schools in Singapore to improve in the schools infrastructure and environmental programmes, and eventually be awarded the Green Mark certificate through Back to School Programme.

Measure

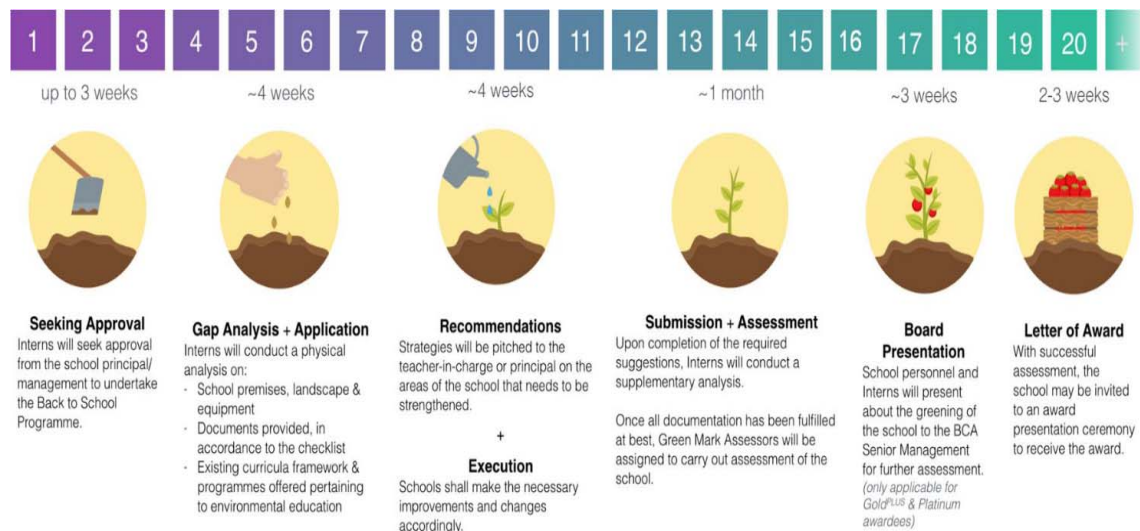

Students involved in the Back to School Programme would be required to carry out the following stages:

From recent past projects, students from Back to School Programme have developed cost effective solutions that have helped many schools to improve their infrastructure and developed useful materials to help schools to step up their environmental education efforts. Some of the measures include:

1. Trend-logging and communication of energy and water consumption trends to students and staff;

2. Health check on school building system (e.g. checking their AHU room, lighting level);
3. Design and creation of a green corner to provide learning materials and conducive environment for self-learning on sustainability issues;
4. Implementation of green procurement policy;
5. Recommendations on more energy efficient air condition models to look out for
6. Provide recommendations and materials to improve school wide sustainability awareness and education; or
7. Provide strategies to reduce energy and water consumption through behavioural change.

Performance



During the programmes' pilot phase, 12 students have been deployed to 10 schools and have successfully assisted these 10 schools in achieving their Green Mark certification.

	Schools	GM Award
1	Admiralty Secondary School	Gold
2	Beatty Secondary School	Gold ^{Plus}
3	Pei Cai Secondary School	Gold
4	Da Qiao Primary School	Gold ^{Plus}
5	Hong Wen School	Gold ^{Plus}
6	Xinghua Primary School	Gold
7	Ang Mo Kio Secondary School	Gold
8	Chung Cheng High School (Main)	Gold
9	Serangoon Garden Secondary School	Gold
10	Serangoon Secondary School	Gold

Having been Green Mark certified after the Back to School Programme, these schools have complied with the Green Mark for Existing Schools criteria and ensured that the following were implemented:

1. Health check on school existing building systems;
2. Better documentation of school's equipment and facilities;
3. Sufficient environmental sustainability education programmes;
4. Initiatives to encourage students to take ownership and lead environmental programmes;
5. Healthy Indoor Environment Quality (IEQ) is provided in school;
6. Energy and water efficient building systems, therefore minimizing utility consumption;
7. Sustainable consumption of resources to reduce potential environmental impact, waste and pollution.

Building on the success of this pilot phase, this programme will be officially roll-out to cover all mainstreams schools in Singapore.

	
<p>Back to School Students conducting sharing session with school management on Green Buildings, Green Procurement Guide, and Green Practices.</p>	<p>Back to School Students conducting gap analysis by checking the efficiency of air conditioners before sharing with the schools on more efficient</p>

air-conditioners that the school may procure prior during their next round of retrofit.



Before and after photos of Green Corner at Peicai Secondary School designed by Temasek Polytechnic students involved in the Back to School Pilot Programme in 2015



The Back to School students conducting workshops on green buildings and practices for their juniors in schools.

The Back to School students put up recycling posters designed by students on bins at Hong Wen School as part of the Back to School Programme.

-See more at:

<http://esci-ksp.org/project/singapores-back-to-school-internship-programme/>

BCA-MOE Back to School Programme

Structured Internship Programme for Institutes of Higher Learning (IHL) Students

Presented by:
Ng Sian Ching
Executive Manager
Building and Construction Authority



Why Green Schools?

Starting Students Young

- Evoke behavioural and mindset change

*Changing their
consumption
behaviour*

*Changing their
perspective of the built
environment sector*

- Provide a future ready and conducive learning environment to empower the next generation with skill and knowledge on sustainability

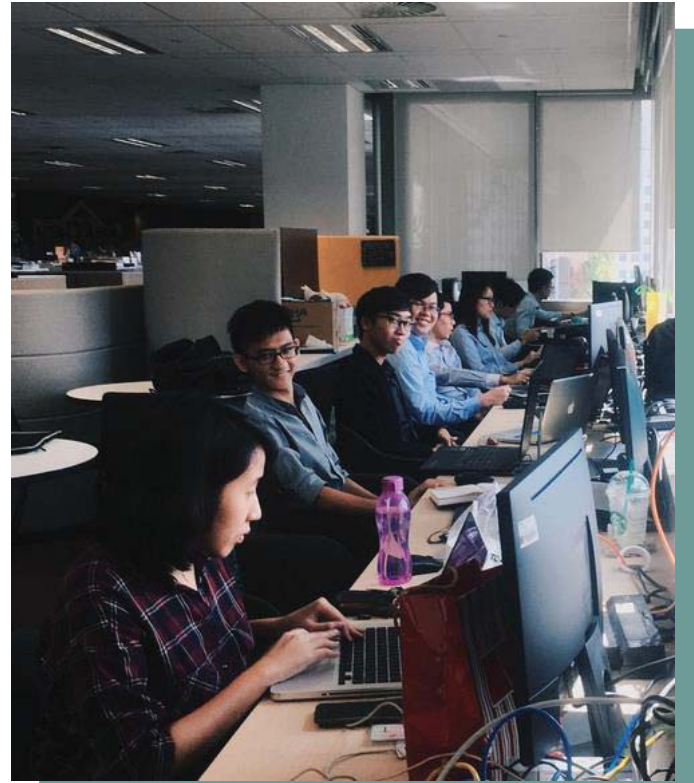

5 ASPECTS OF A GREEN BUILDING

01 ENERGY EFFICIENT

02 WATER EFFICIENT

03 SUSTAINABLE AWARENESS & MANAGEMENT

04 HEALTHY INDOOR AIR QUALITY

05 BONUS GREEN FEATURES

How to Green Schools?

BCA Green Mark Scheme

- Green Mark for Existing Schools Criteria
- Guide and benchmark to facilitate schools in **Greening Schools' Infrastructure** and **Greening Student Community**



BCA GREEN MARK

How to Green Schools?

Back to School Programme to get schools GM certified

Typical Duration: 3 to 5 months



Benefiting Stakeholders in B2S Partnership

Guided Mentorship

- Shared mentorship between BCA officers and partners of Back to School
- Career guidance for students bringing students into BE sector
- Exposure to other Green Mark projects and green building related careers



Benefiting Stakeholders in B2S Partnership

Employ interdisciplinary skills in real world context

Presentation skills convince alma mater to come on board



Interpersonal skills when interacting with stakeholders

Technical skills employed during Green Mark gap analysis and health check on schools



Benefiting Stakeholders in B2S Partnership

Co-creating measures to green schools



Propose energy efficient equipment during next round of A&A works



Green corner for self directed learning



Posters and educational materials to green schools

- Working with school and guided by BCA mentors to co-create measures tailored to schools' needs
- Students able to implement recommendations proposed
- Safe environment for students to innovate

Benefiting Stakeholders in B2S Partnership

Further sustainability messages

- Beyond Green Mark
- Tapping to students and schools to further sustainability messages

Sharing sessions for school's staff on green buildings



Green Mark workshop to teach students on greenery provision calculation



Senior GREENtern guiding junior GREENterns



Effective Engagement
through Experiential Learning



Expose students to sustainability and green building careers



Effective Engagement through Experiential Learning



Provide students with a platform to employ skills and knowledge internalised in school and during internship



Effective Engagement through Experiential Learning

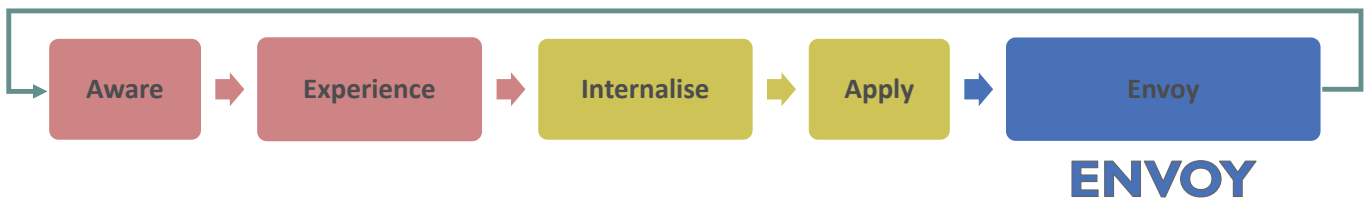

Engaging students as vehicles and envoys spearhead initiatives to spread sustainability messages and green habits

建设局“回返校园”计划 工院生实习后回母校助推绿化工作

2016年9月10日 星期六 03:30 AM 文/林心惠来自/联合早报

[Twitter](#) [Email](#)

这项新计划让在籍工院学生到建设局实习，掌握绿化工作的相关知识和然后化身“绿化顾问”重返各自的母校，帮助校方制定新措施加强节能环保工作。



Recognition for Back to School



Next Steps

Working with MOE to Green Schools

- Meaningful platform for students
- B2S as main measure to green all ~350 MOE mainstream schools



Next Steps

Expanding IHLs Participation

Expecting more than 20
GREENterns for FY17

Confirmed Participation in Back to School 2017



Next Steps

Bringing in Industry Partners

- Provide guidance and share experience with students
- Provide students with industry exposure and exposure to wider range of projects



G-ENERGY
GLOBAL

ADDP
ARCHITECTS LLP





BCA-MOE Back to School Programme

End of Presentation

Presented by:
Ng Sian Ching
Executive Manager
Building and Construction Authority

Low Carbon Model Towns

**Solar Powered City
- Tainan Reaches for the Sun**

(Gold)

William Lai, M.D. (Lai Ching-te)

Mayor of Tainan

Education:

- B.S., Department of Physical Medicine and Rehabilitation, College of Medicine, National Taiwan University
- M.D., Department of Medicine, College of Medicine, National Cheng Kung University
- Master, Public Health, Harvard University, USA

Career Highlights:

- Doctor in Charge, Nephrology, National Cheng Kung University Hospital
- Doctor in Charge, Nephrology, Sin Lau Hospital, the Presbyterian Church of Taiwan
- Member, the 3rd National Assembly.
- Legislator, the 4th, 5th, 6th, and 7th Legislative Yuan.
- Co-Chair, Social Welfare and Environmental Hygiene Committee, the 4th and 5th Legislative Yuan
- Co-Chair, the Judiciary Committee, the 5th Legislative Yuan
- The 13th President, Health, Welfare and Environment Foundation, Legislative Yuan
- Whip of DPP Caucus, the 6th and 7th Legislative Yuan
- Visitor, the International Visitor Leadership Program, the US Department of State, 2004
- Adviser, National Teachers' Association.
- Mayor of Tainan (2010- present)

Solar Powered City - Tainan Reaches for the Sun

Chinese Taipei

Managing Organization:Economic Development Bureau, Tainan City Government

Project Description:

From the Dutch ruling to Ming and Qing Dynasty, Tainan was Chinese Taipei's political and economic center that benefited from the fishing and salt making businesses. The earliest developed salt field at Rushing Current Mouth now the site of internationally well-known Jingzaijiao Tile-paved salt fields and Cigu Salt Mountain punctuating the advantageous conditions of Tainan with the annually average 2,181 sunshine hours and the generation of annual capacities of 1,343 KWh. In 2011, with the combined opinions and consensus reached by the industry, the government, academia, and research institutions, the Tainan City Government enacted the proposal for the building of a low carbon city and were ratified by the Environmental Protection Administration of Executive Yuan as "the only demo city in Southern part of Chinese Taipei ." In the same year, the Solar City Project was initiated.

In 2011, the Solar City Project was launched; the City Government provided comprehensive services for promotion (organization of seminars), counseling (services windows at different districts), subsidies (for financial encouragement), and application reviews. In coordination with the mandatory measures of autonomous regulations, the determination to build great Chinese Taipei into a low carbon and green energy city was conveyed. For the promotion in the past five years, the Tainan City Government approved 2,824 solar energy installation and seventeen solar community applications with the capacity over 156 megawatts. In the future, the capacity is expected for a continuous growth to achieve the goal of building "the Solar City-Great Tainan" that reduces carbon emission and generates green energy.

Brief outline of the low carbon town development plan:

Five Items for Promotion

The development of renewable energy that suits local demands needs to also consider the high density and crowded population in Chinese Taipei. Due to the high value of land, we choose to make use of the idle spaces to install photovoltaic system as the main source to develop renewable energy. In 2011, the “Solar Power City” was launched with the goals to promote five items including solar public housing, solar roofs, solar communities, green factories, and agriculture greenhouses. Flush connection is used for tilt roofs, and trellis photovoltaic systems are installed on the dead-level roofs without any interruption of original spatial use of roofs.

1. Solar Public Housing

In consideration of limited budgets of local government, the Tainan City Government took the lead in Chinese Taipei to lease public housing roofs with open tenders for the bid winner to install photovoltaic system on the roofs of public housing. The installation and other relevant fees are at the cost of bid winner, and the winner then pay the rent of roofs to Tainan City Government according to the payback percentage (income of electricity sold * payback percentage = roof rent). Public housing included in the tenders are places often accessed by the public such as public retailer markets, schools, district offices, community centers, libraries, stadiums, health centers, land/household registration offices, tax bureaus, police stations, fire bureaus, office buildings owned by the Tainan City Government. After construction, the Tainan City Government will arrange for on-site public visits to avoid concerns and gain public recognition. It is expected that with the demonstration of photovoltaic systems installed on buildings of public sector, more citizens and enterprises will follow to install photovoltaic systems on the roofs of community, residential, factory, and agricultural facility buildings.

2. Solar Roofs

We have shared the successful cases of solar public housing and promoted the installation of photovoltaic systems on the roofs of private buildings. Through seminars and observatory meetings, the public has been encouraged for the use of idled roof to install photovoltaic systems that can increase income of electricity sales and at the same time, the roof temperature can be reduced by two to three degrees to save the electricity expanses.

3. Solar Communities

Unlike the scattered installation of solar roofs, solar communities refer to the aggregated installation of photovoltaic systems on the roofs of collective residential units or apartment buildings by expanding green flashing points to lines to develop demo communities of low carbon and green energy. Additionally, representatives of successful solar communities are invited to participate in promotion seminars as solar lecturers to share installation experiences for the promotion of solar communities and building the public consensus on carbon reduction.

4. Green Factories

During operation, the temperature at factories rises, and factory roofs are often the idle spaces not in use. If roofs can be installed with photovoltaic systems, the temperature at factories can be reduced to cool down workplace temperature and to cut down electricity bills. At the same time, electricity generated can be sold for additional income and enterprises can build their green business image. In order to encourage and counsel the installation, we actively visit each administrative districts and industry parks to conduct seminars for factories, business buildings, and gas stations. Positive recognitions have been received from the participants.

Meanwhile, according to “Article 23 of Autonomous Rules for Building Tainan City as a Low Carbon City,” electricity contract users with the consumption more than 800 KW needs to install photovoltaic systems more than 10% consumption capacities

within three years after the date of promulgation to reduce the environmental impacts brought by the big users and to enable them to fulfill social responsibilities.

5. Agricultural Facilities

Roofs of agricultural facilities such as chicken coops, pig houses, sheep pens, cattle depots are built with iron or asbestos sheets. After exposed to the hot sunshine in Tainan, the roof temperature is high enough to hinder the growth of animals and affect the yields of animal feeders. Thus, animal feeders often use water spray system to reduce the temperature. Water is valuable resource, and if we can make use of photovoltaic systems installed on the roofs, thermal insulation efficiency can be reached to reduce roof temperature, prolong the use life of iron and asbestos roofs, water resource can be saved, and extra income can be generated. There are multiple benefits!

“After installing the photovoltaic system on the roof top of pig pen, it becomes cool. Look, my piglets are so happy. They grow well, and I can sell them at good prices. Additionally, I have the income for selling electricity, and I am happy, too,” said the owner of a pig farm in Houbi.

See more at :

<http://esci-ksp.org/project/great-tainan-the-solar-city/>



Solar Powered City

TAINAN

Tainan Reaches for the Sun

3rd APEC Energy Smart Communities 2017 Competition
Low Carbon Model Town Workshop Gold Medal

Report by the Tainan City Government

Tainan City Government

Report Outline

- 1 Introduction
- 2 Solar Powered City Project
- 3 Successes
- 4 Future Prospects

Tainan City Government

Introduction

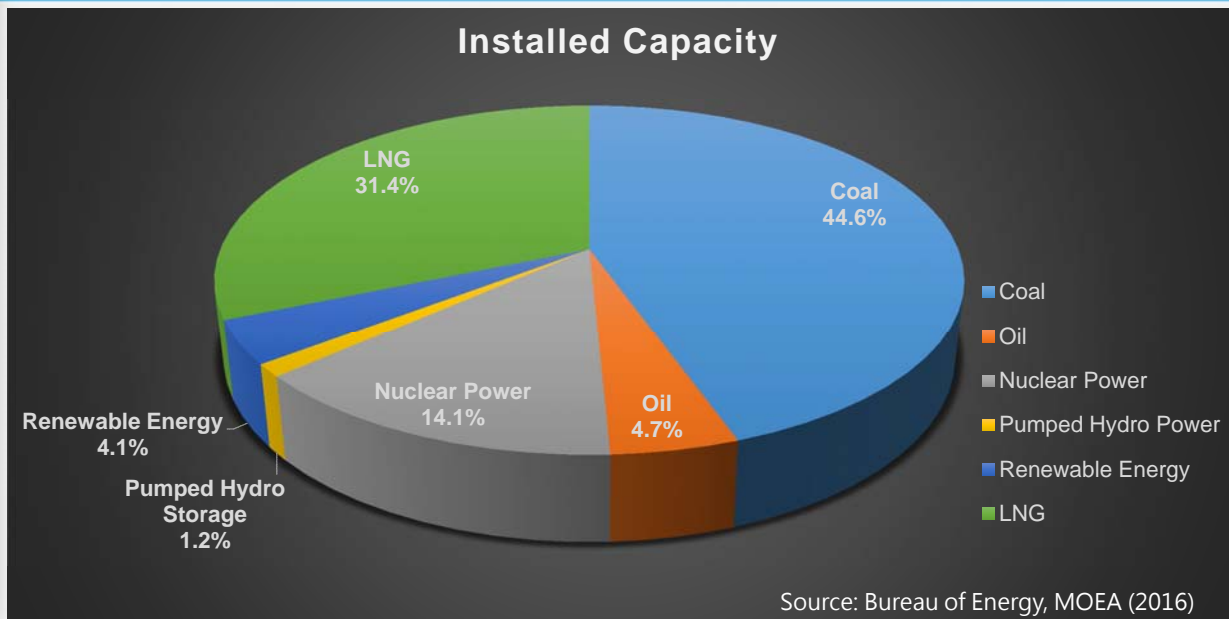

Solar Powered City Project

Tainan's 4 Major Advantages

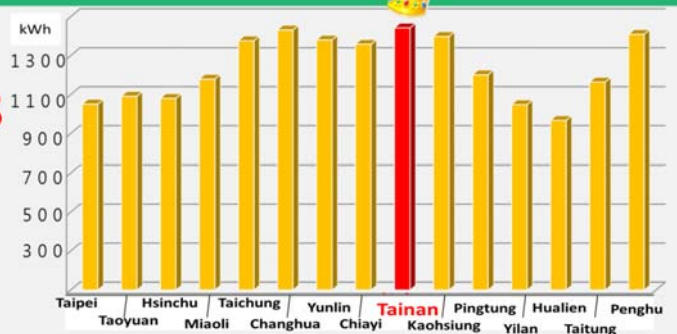
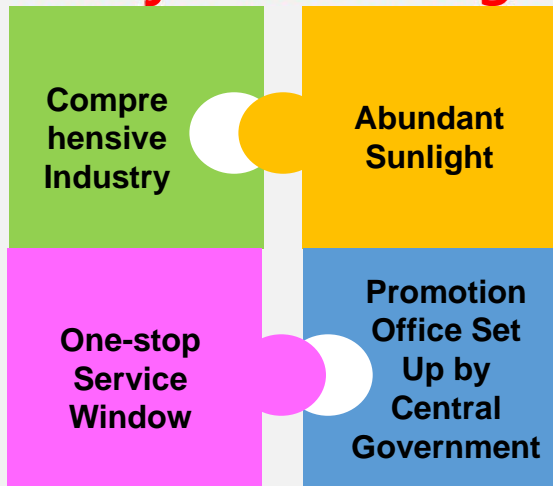

Solar Powered City Project

➤ 5 Major Projects



Solar Powered City Project

➤ 6 Promotion Policies



Successes

Two Years Ahead of Schedule!

- Realized goal of **220MW** in 2016.
- **3,541** applications with an installed capacity of over **233MW** have been approved.
- Nearly **300 million kilowatt hours** of electricity generated annually; reduction of almost **1.6 million tons** of carbon.

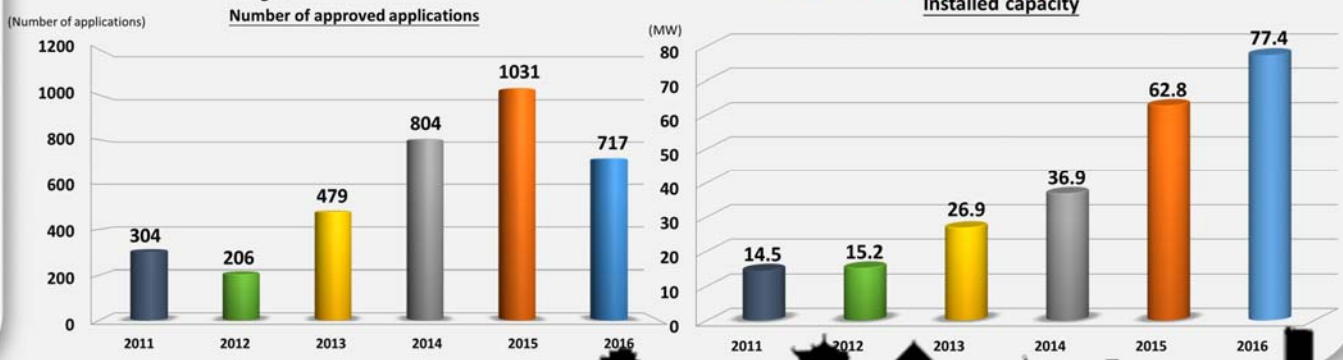

Future Prospects

- Continue to promote installation of five major rooftop type and four land surface type solar powered generator facilities.
- The goal is to achieve **another 220MW** of installed capacity **within 2 years**



Future Prospects

- Shalun Green Energy Science City to be a major center for science and technology in southern Chinese Taipei.

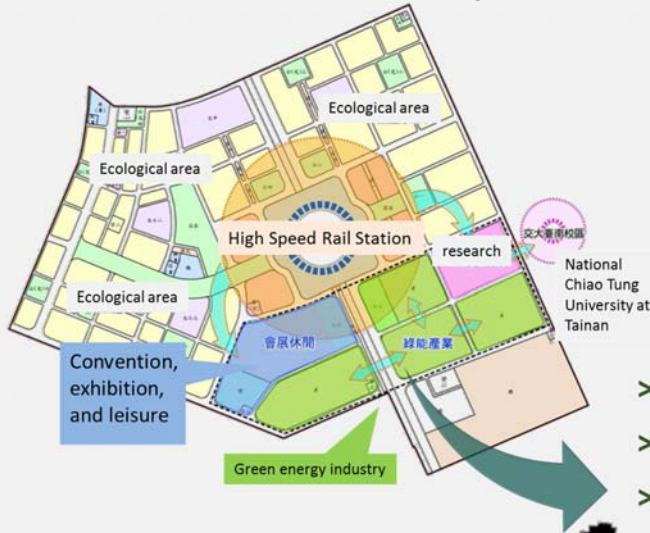

- > 2016 Set up office
- > 2019 Finish construction of Joint Research Center
- > 2020 Finish construction of demonstration sites

Future Prospects

- International standards indices for cities, pursue sustainable development for the city

ISO 37120 standards project consists of some **100** items in **17** areas

Economy	Governance	Telecommunications
Education	Health	Transportation
Energy	Recreation	Urban Planning
Environment	Safety	Wastewater
Finance	Shelter	Water & Sanitation
Fire & Emergency Response	Solid Waste	

2017 data audit launched





Thank you
for
listening