



**Asia-Pacific  
Economic Cooperation**

**Advancing** Free Trade  
for Asia-Pacific **Prosperity**

# **Exchange and Training on Clean Coal Technology and Clean Energy Policy**

**APEC Energy Working Group**

December 2019

APEC Project: EWG 14 2018 S

Produced by

YU Zhufeng

Clean Coal Technology Transfer Program Joint Operation Center, APSEC

Research Garden of Shenhua Innovation Base, Future Science Park

Changping District, Beijing 102211, China

Telephone: +86 10 5733 9975

Fax: +86 10 5733 9999

For

Asia-Pacific Economic Cooperation Secretariat

35 Heng Mui Keng Terrace

Singapore 119616

Tel: (65) 68919 600

Fax: (65) 68919 690

Email: [info@apec.org](mailto:info@apec.org)

Website: [www.apec.org](http://www.apec.org)

© 2019 APEC Secretariat

APEC#219-RE-01.18

## Preface

In global power supply, coal plays an important role, especially in the Asia-Pacific region, where coal reserves and production accounted for 30% and 70% respectively over the world. The endowment, availability and economy of coal determines that coal power will remain a significant base energy source in the world, especially in the Asia-Pacific economies for quite a long time. Meanwhile in the future, over half of the increase of global coal power supply will come from the Asia-Pacific economies.

With the trend of low-carbon development and green economy around the world, all economies are actively speeding up the development of clean energy such as renewable energy. In the meantime, they are improving energy efficiency and reducing carbon dioxide emissions through energy conservation and enhancing the clean utilization of fossil energy.

China is the world's largest consumer and producer of coal. The Chinese government is actively promoting the "Four Revolutions and One Cooperation" (namely the revolutions of energy consumption, energy supply, energy technology and energy system, and strengthened all-round international cooperation) energy strategy. With great devotion to developing clean energy such as renewable energy and carrying out the R&D and demonstration of CCS/CCUS technology, China is actively pushing forwards the development and utilization of the Clean Coal Technology (CCT) further to improve the clean and efficient utilization of coal. China's several clean coal technologies have ranked the top in the world, which has greatly contributed to energy saving and regional pollution solving in China.

To be further engaged in global energy and environment governance, under the APEC mechanism the Chinese government established APEC Sustainable Energy Center (APSEC) in September 2014. Afterwards, Clean Coal Technology Transfer Program Joint Operation Center (CCT Center) was co-founded by APSEC and China Energy Investment Corporation Limited (China Energy).

The main task of CCT Center is to summarize the application outcomes and development experience of CCT in China and share them with the APEC economies and even the whole world. Thus, the Center organized a group of renowned experts from China's universities, design institutes and enterprises to compile this textbook and make a systematic summary of the ideas, technology paths and relevant cases of CCT in China. Through the conclusion and exchanges of the clean energy policy and CCT development experience, the Center aims to provide a reference to the APEC economies, especially the developing economies for dealing with environmental problems caused by coal utilization; and to explore possible technical approaches to achieve low-carbon utilization of high-carbon energy together with APEC member economies.

Thanks to China Energy for supporting the compilation of this textbook. Also, sincere gratitude goes to all experts involved in compiling this textbook and to experts from China Electricity Council (CEC), Electric Power Planning & Engineering Institute (EPPEI) and other institutes for strictly reviewing this textbook.

CCT Center

May 2019

## Contributors

Writers: Yuan Jiahai      Ye Yongjian      Lv Junfu  
Liu Junliang      Ge Zhihua      Zhang Yi  
Zhang Shuai      Xu Zhaofeng      Yu Zhufeng  
Xiao Lingjuan      Zhang Jianyun      Liu Aiguo  
Chao Ketu

Verifier: Xiao Chuangying      Jiang Wenhua      Liang Zhihong  
Wu Shaohua      Long Hui      Liu Zhiqiang  
Zhang Weidong      He Zhao

Translators: HBO (Beijing) Science & Technology Co. Ltd

Zhang Jianyun      Gao Hua      Liu Aiguo

Yang Hairui

# Contents

<b>Chapter I Introduction.....</b>	<b>1</b>
1.1 CCT Overview .....	2
1.1.1 A Brief Introduction to CCT .....	2
1.1.2 Characteristics of CCT.....	4
1.2 Significance of Developing CCT.....	6
1.2.1 Coal plays an important role in the global energy mix .....	6
1.2.2 Coal-fired power is still one of important power source in the world.....	7
1.2.3 Coal-fired power plays a pivotal role in a diversified power supply mix.....	8
1.2.4 Coal-fired power is a key low-cost energy source.....	9
1.2.5 CCT provides greater competitive edge for coal-fired power industry .....	10
1.2.6 CCT benefits sustainable development of global energy.....	10
<b>Chapter II Overview on the Global Development of Clean Coal Technology.....</b>	<b>13</b>
2.1 Clean and efficient coal-fired power generation technologies .....	14
2.1.1 SC/USC coal-fired power generation technology.....	14
2.1.2 Circulating Fluidized Bed (CFB) Power Generation Technology .....	16
2.1.3 Integrated Gasification Combined Cycle (IGCC) Technology.....	18
2.1.4 Combined Heat and Power (CHP) Technology .....	20
2.2 Flue Gas Pollutant Control Technologies .....	22
2.3 Carbon Capture, Utilization and Storage (CCUS) Technology.....	26
<b>Chapter III Rapid Development of CCT Promoted by China’s Clean Energy Policy .....</b>	<b>31</b>
3.1 China’s macro policy supports the efficient, clean and low carbon development of energy.....	32
3.2 State policy encourages the energy diversification .....	37
3.2.1 Orderly control conventional power expansion.....	37

3.2.2 Vigorously promote renewables.....	38
3.2.3 Actively exploit hydropower.....	39
3.2.4 Prudently develop nuclear power.....	39
3.3 State policy promotes the rapid development of CCT .....	41
3.3.1 Driven by innovation-accelerate the technological development for the clean coal utilization.....	42
3.3.2 Led by legislation-lead CCT development with laws and regulations .....	43
3.3.3 Standardized by norms-make strict standards on the air pollutant emission for coal-fired power plants .....	44
3.3.4 Guided by planning-guide the quality development of coal-fired power plants through multi-tier planning .....	47
3.3.5 Supported by industrial policy-formulate policies to raise the threshold for new units, retrofit and upgrade existing units, and eliminate backward capacity	50
3.3.6 Readjusted for better functioning-retrofit coal-fired power plants for better flexibility retrofit so as to help stabilize the grid system and utilize renewable energy.....	52
3.3.7 Guaranteed by mechanisms-guide the coal-fired power industry towards clean and efficient development by economic incentives and regulatory constraints .....	53
3.4 China has achieved remarkable progress in developing CCT.....	56
<b>Chapter IV SC and USC Coal-fired Power Generation Technology in China.....</b>	<b>65</b>
4.1 Development Background .....	65
4.2 Major SC/USC Power Generation Technologies .....	70
4.2.1 Parameter Series of SC/USC Units.....	70
4.2.2 Technical Features of SC Units.....	72
4.2.3 Technical Features of USC Single-reheat Unit .....	73
4.2.4 Technical Features of USC Double-reheat Unit .....	75
4.2.5 Technical Features of Air-cooling Power Generation.....	76
4.3 China’s Achievements in the Application of SC/USC Technology	77
4.4 Policy Drivers .....	78
4.5 Typical Cases of Project Construction and Operation.....	81

4.5.1 Taizhou Power Plant .....	81
4.5.2 Ninghai Power Plant .....	87
4.5.3 2×1050MW Coal-fired Power Generation Project, Java No.7, Indonesia...	91
<b>Chapter V Power Generation Technology of Circulating Fluidized Bed in China.....</b>	<b>95</b>
5.1 Development of CFB power generation technology for the utilization of numerous inferior coals .....	95
5.2 The development history of CFB boiler in China .....	97
5.3 Main technologies of the CFB boiler power generation in China...	97
5.3.1 Subcritical and below CFB power generation technology .....	97
5.3.2 SC CFB power generation technology .....	99
5.3.3 Ultra-low emission CFB combustion technology based on fluidization state optimization .....	101
5.4 Policy Drivers for CFB power generation industry.....	102
5.4.1 Policy Drivers for CFB power generation industry .....	102
5.4.2 Fiscal and tax policy drivers for CFB power generation .....	104
5.5 Application achievements of CFB power generation technology in China .....	106
5.5.1 A complete set of CFB design, manufacturing and construction technology.....	106
5.5.2 Great amount of inferior coal utilized with CFB power generation technology .....	106
5.5.3 CFB boiler technology based on fluidization state specification in commercialization.....	107
5.5.4 Rapid development in SC CFB power generation technology .....	108
5.5.5 Ultra-low emission CFB combustion technology leads CFB international development.....	109
5.6 The significance of developing CFB power generation technology .....	110
5.7 Typical cases of China CFB power generation technology.....	111
5.7.1 The 600MW SC CFB demonstration –Sichuan Baima power plant of China	



Energy .....	111
5.7.2 350MW SC CFB Power Generation-Xuzhou Mining of Hua Mei Thermo-Electric Power .....	113
5.7.3 50MW Energy-saving CFB boiler-Shanxi Huoshi Captive Power Co. Ltd.....	114
5.7.4 100MW CFB power generation with pure combustion biomass- Biomass Electricity Co., Ltd in Thailand. ....	116
<b>Chapter VI CHP Technology in China .....</b>	<b>119</b>
6.1 Development History and Current Status .....	119
6.1.1 Necessity of Developing CHP in China.....	119
6.1.2 Development course of CHP .....	122
6.1.3 Current Status of CHP .....	123
6.2 CHP Policies and Future Directions .....	123
6.3 Principal CHP technologies in China .....	125
6.3.1 Extraction Condensing Technology .....	126
6.3.2 Back-pressure technology .....	129
6.3.3 Retrofit technologies for the existing plant.....	131
6.4 Typical CHP Cases.....	137
6.4.1 CHP plant in Light Industrial Park, Hailun.....	137
6.4.2 Low vacuum retrofit technology in the CHP plant, Guodian Dalian.....	138
6.4.3 2×660 MW CHP plant in Dianta.....	141
6.4.4 2×150MW Power plant, South Sumatra in Indonesia .....	143
<b>Chapter VII Flue Gas Pollutant Control Technologies in China.</b>	<b>147</b>
7.1 Background.....	148
7.2 Main Technical Routes for Flue Gas Pollutant Control .....	150
7.2.1 Technical route for ultra-low dust emission.....	151
7.2.2 Technical route for ultra-low SO <sub>2</sub> emission .....	153
7.2.3 Technical route for ultra-low NO <sub>x</sub> emission.....	155
7.3 Policy Drivers .....	156
7.4 Achievements in Ultra-Low Emission Implementation .....	158

7.5 Significance of ultra-low emission .....	159
7.6 Cases of project construction and operation.....	161
7.6.1 Zhejiang Zhoushan Power Plant .....	161
7.6.2 Hebei Sanhe Power Plant.....	163
7.6.3 Economics of ultra-low emission.....	169
<b>Chapter VIII CCS/CCUS Technology in China .....</b>	<b>171</b>
8.1 CCS/CCUS R&D in China.....	172
8.1.1 CO <sub>2</sub> Capture R&D .....	173
8.1.2 R&D of CO <sub>2</sub> Storage Technology.....	178
8.1.3 R&D of CO <sub>2</sub> Utilization Technology.....	179
8.2 CCS/CCUS Industrial Demonstration and Application in China..	180
8.3 Typical Industrial Demonstration Projects .....	183
8.3.1 Huaneng Greengen IGCC Demonstration Project.....	183
8.3.2 PetroChina Jilin Oilfield CCS-EOR Demonstration Project .....	185
8.3.3 Shenhua 100,000 ton/year CCS Demonstration Project .....	186
<b>Chapter IX      Significance and Demand of Developing CCT in</b>	
<b>the APEC Region .....</b>	<b>189</b>
9.1 The Ever-growing Power Demand in the APEC Region .....	189
9.1.1 Rapid Growth of Primary Energy Demand .....	189
9.1.2 Rapid Growth of Power Demand.....	190
9.2 Significance and Challenges of Developing CCT in the APEC region	
.....	193
9.2.1 CCT Can Ensure Sufficient Supply of Electricity .....	193
9.2.2 CCT Has Cost Advantages.....	193
9.2.3 CCT Can Meet Environmental Protection Requirements.....	194
9.3 Analysis on Future Demand for CCT .....	195
9.3.1 Demand Forecast of CCT .....	195
9.3.2 Analysis and Suggestions on Future Demand for CCT .....	199
<b>Annex I Abbreviation and Acronyms .....</b>	<b>202</b>
<b>Annex II Units.....</b>	<b>203</b>

## Chapter I Introduction

To reduce global pollutant emissions and address global warming, several economies, including the United States, the European Union, and Japan, have carried out R&D on Clean Coal Technology (CCT) since 1980s. Over decades, they have achieved great results in improving coal utilization efficiency and reducing pollutant emissions.

CCT is a general term for technologies that reduce pollutant emissions and improve efficiency in coal development and utilization, including technologies in coal processing, conversion, combustion and pollution control. Generally speaking, CCT can be divided into four categories<sup>[1][2][3]</sup>:

1. pre-combustion coal processing technology, including coal washing and coal water slurry (CWS);
2. clean and efficient coal-fired power generation technologies, including supercritical (SC) power generation, circulating fluidized bed (CFB) and IGCC;
3. coal conversion technology, including gasification and liquefaction;
4. post-combustion pollutant control and resources recycling, including flue gas purification, “CO<sub>2</sub> capture, utilization and storage” (CCUS), and integrated utilization of coal gangue and coal ash.

In face of an ever-increasing demand for global energy and greenhouse gas issue, developing CCT is a realistic and effective means for reducing pollution and carbon emissions.

This textbook is intended to be used for the *Exchange and Training on Clean Coal Technology and Clean Energy Policy, APEC Self-Funded Project (EWG 14 2018S)*. In global energy mix, coal plays an important role: 69% of coal in the APEC region are used for power generation<sup>[4]</sup>. Considering that recent CCT development focuses on clean and efficient

coal-fired power generation technologies and post-combustion pollutant control, **in this textbook**, (as approved by the APEC Energy Working Group at the 56th Session and reviewed by the APEC Secretariat) **CCT particularly refers to Category 2- clean and efficient coal-fired power generation technologies - and Category 4- pollutant control of flue gas, and CCUS**. Summarizing and exchanging China's experience in clean energy policy and CCT development, this textbook attempts to help APEC economies, especially developing economies with rich coal resources, to make better use of coal in power generation, to provide insights into environmental problems caused by coal, and to explore technical means to achieve low-carbon utilization of high-carbon energy source.

## **1.1 CCT Overview**

### **1.1.1 A Brief Introduction to CCT**

Currently, there are several major CCT technologies<sup>[5]</sup>:

(1) Supercritical (SC) and ultra-supercritical (USC) coal-fired power generation, featuring high temperature, pressure and capacity

SC power generation occurs when main steam pressure of a coal-fired generator unit reaches about 24 MPa, with main steam/reheat steam temperature reaching 538-560°C. USC power generation, according to existing data of USC units, occurs when main steam pressure reaches beyond 25 MPa, with a main steam temperature over 580°C.

(2) Circulating fluidized bed (CFB) boiler technology

CFB is a power generation technology that utilizes combustion in a

circulating fluidized bed boiler to heat fluid, thereby generating main steam that drives the steam turbine. CFB technology is an effective way to use inferior fuel in large quantity, because it enjoys such advantages as great fuel adaptability, highly-adjustable load and easy reuse of cinder.

### (3) Combined heat and power (CHP) technology

CHP technology uses a variety of fossil fuel and renewable energy to produce both power and heat in a combined process. By replacing decentralized and limited-capacity coal-fired boilers, CHP units can improve energy efficiency while reducing pollutant emissions.

### (4) Emissions control in coal-fired power generation

These technologies are composed of several control technologies in pre-combustion, combustion, and post-combustion. Pre-combustion technologies include coal washing and pyrolysis/gasification; combustion technologies include low NO<sub>x</sub> burner technology and in-furnace sulfur fixation; post-combustion technologies include desulfurization, denitrification and dedusting. With coordinated post-combustion control technologies, emissions from coal-fired power generation can be reduced to below the limits for natural gas-fired generation.

### (5) Integrated Gasification Combined Cycle (IGCC)

IGCC technology starts with coal gasification; then the coal-gas is purified and fed into gas turbine to generate power; the high-temperature flue gas discharged from the gas turbine enters the heat recovery boiler to generate steam, which then generates power through steam turbine. IGCC is an integrated energy system that can achieve multiple benefits in resources,

energy and environment. Currently, such technology appears less commercially competitive than conventional coal-fired power, due to economics and reliability issues; but in the long run, IGCC will exhibit great potential for its advantages in reducing global CO<sub>2</sub> emissions.

### 1.1.2 Characteristics of CCT

#### (1) Ready for large-scale application

SC, USC and CFB technologies have been widely promoted and commercially applied around the world for their good availability, reliability, adaptability and long equipment lifetime. They have become efficient, clean and economical technologies for coal-fired power generation, along with the development and application of such emissions control technologies as desulfurization and denitrification.

#### (2) Clean, efficient and resources-saving

As major parameters of USC and SC coal-fired power generation units keep growing and more operational and managerial experience is gained, generation efficiency improves, coal consumption decreases, and pollutants discharge per unit of power generation is significantly reduced. Through flue gas treatment, the discharge amount of a conventional coal-fired power unit can be contained within the limits for gas-fired power units.

#### (3) Strong technical applicability

Now, unit capacity of commercialized coal-fired power ranges from 10MW to over 1000MW. This means that these units with clean and efficient coal-fired power generation technologies can be used as a core power source in the region, capable to meet a variety of demand in power

load in different areas. CFB technology can generate clean power efficiently using different types of coal (especially low-grade coal). CHP technology can provide both power and heat for regions in need of both, improving energy efficiency while reducing emissions.

#### (4) High reliability and a strong support to power grid

As power sources diversify, coal-fired power generation plays an increasingly crucial role in power system. According to statistics in China Power Reliability Report 2017<sup>[6]</sup>, 91 1000MW-level coal-fired power units reported an Equivalent Availability Factor (EAF) over 92.72%, with Unplanned Outage Times (UOT) lowered to 0.42 times/unit-year. For outstanding safety and reliability, coal-fired power still plays a fundamental role in maintaining security and stability in power supply and contingent peak shaving.

#### (5) Outstanding cost-effectiveness

In most parts of the world, coal enjoys low cost under limited price fluctuation. As more coal-fired power generation technologies are commercially applied, the investment cost continues to decrease. In most areas where coal is the primary energy source, coal-fired power generation has a clear competitive edge over other types of power generation.

#### (6) Decreasing CO<sub>2</sub> emission

Following a green wave of low-carbon development around the world, clean and efficient coal-fired power generation technology can reduce CO<sub>2</sub> emission intensity by improving efficiency and reducing coal consumption. Moreover, technologies such as CCUS can further reduce CO<sub>2</sub> emission.

Applying CCUS in coal-fired power plants will reduce a large amount of CO<sub>2</sub> emissions. At present, CCUS has not yet achieved large-scale commercialization due to economics and other reasons, but its R&D has been ongoing around the globe, and several coal-fired power plants are carrying out CCUS industrial demonstrations.

Driven by increasing power demand, technology advances in environmental protection, and dropping costs in power generation, coal-fired power is becoming safer, cleaner, more efficient, reliable, and flexible.

## **1.2 Significance of Developing CCT**

### **1.2.1 Coal plays an important role in the global energy mix**

Coal is the most abundant fossil-fuel in the world. As global economy surges with rapid modernization, urbanization and electrification, the world's total primary energy supply has increased from 8,773 Mtoe in 1990 to 13,760 Mtoe in 2016, a near 60% increase (Figure 1-1). In 2017, coal accounted for 27% of global primary energy supply, and remains one of the most important basic energy sources<sup>[7]</sup>. 30% of global coal reserves and 70% of coal production concentrate in Asia-Pacific region<sup>[8]</sup>. Because of such abundant reserves and relatively low cost, coal remains the most important energy source in many APEC economies.



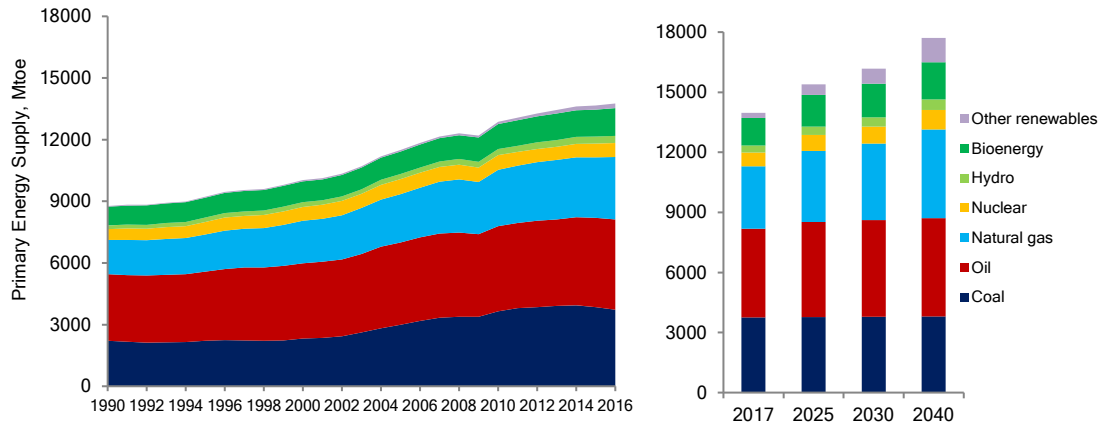
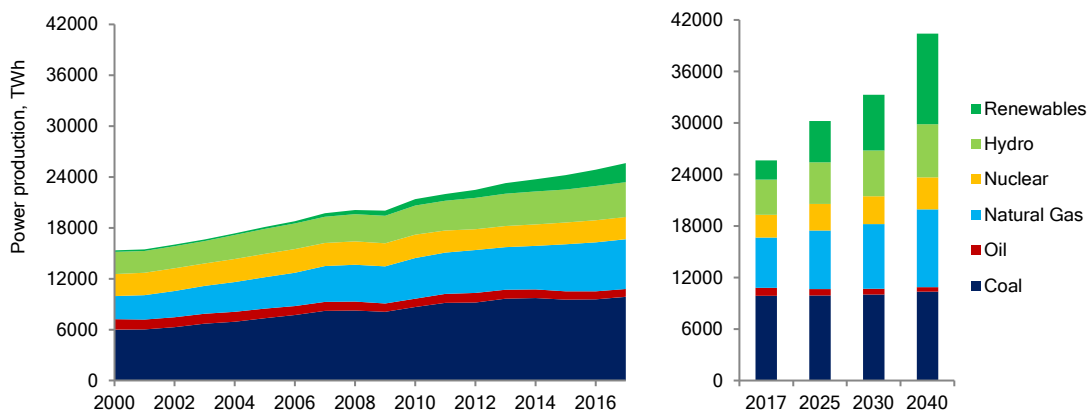

**Figure 1-1 Global Primary Energy Supply Mix and Forecast (New Policy Scenario)**

Source: IEA. World Energy Outlook 2018

### 1.2.2 Coal-fired power is still one of important power source in the world

Coal-fired power plays an important role in the global power supply. Global coal consumption mainly concentrates in power and thermal industries. In 2016, the total global coal consumption reached 3,731 Mtoe, of which 65.3% of raw coal was used for power and heat production<sup>[9]</sup>. Coal, gas, and hydro dominate power production mix, accounting for 38.3%, 23.1%, and 16.6%, respectively<sup>[10]</sup> (Figure 1-2).



**Figure 1-2 Global Power Production Mix (1990-2017) and Forecast**

Source: IEA. World Energy Outlook 2018

In 2017, global coal-fired power generation increased by 3% year-on-year. Coal-fired power witnessed rapid growth especially in the Asia-Pacific region. As China and Southeast Asia consume a great amount of power and new demand emerges, future growth of coal-fired power will mostly come from the Asia-Pacific region. Coupling with great availability, abundance and reliability of the resource, most of these economies will continue to rely on coal in their industrialization. This will make clean and efficient use of coal crucial in safeguarding their energy security and alleviating pressure on the world's oil and gas supply.

### 1.2.3 Coal-fired power plays a pivotal role in a diversified power supply mix

The world's power mix is becoming increasingly diversified, of which renewables, hydro, nuclear, coal, gas and oil power complement each other, underpinning world economy growth. Renewable energy is expanding fast with an increasing share in the world's power mix.

However, among the renewables, wind and photovoltaic (PV) power are sporadic and volatile in nature, and small on the scale. On the other hand, clean coal-fired power is growing in production capacity as technology moves forward: the maximum capacity of efficient coal-fired power generation has exceeded 1000MW. Not only does coal-fired power have advantages in scale, it is also a great way for centralized power generation (as a base-load power source): coal serves as a continuous and reliable power supply for economic growth; it also has economic advantages in peak shaving, frequency adjustment and voltage regulation. For some specific regions especially which are rich in coal, coal-fired power will

continue to play a crucial role in power supply mix, ensuring a safe and stable power system<sup>[11]</sup>.

### 1.2.4 Coal-fired power is a key low-cost energy source

For APEC economies with abundant coal resources and convenient supply, coal is cheaper than oil and natural gas, and coal supply is more stable. Therefore, coal-fired power has a more obvious economic advantage.

Especially for some developing economies, coal-fired power underpins their fast-growing economic and social development, by providing low-cost electricity. Coal has great significance for regional energy security, economic growth, social progress and the improvement of people's life. According to IEA's research on Indonesia and several other Southeast Asian economies<sup>[12]</sup>, SC coal-fired power generation has great advantages in costs, when compared with either renewable energy such as wind and PV power, or traditional oil and gas (see Figure 1-3).



**Figure 1-3 Comparative cost of power generation in Indonesia and other Southeast Asian economies**

Source: IEA Southeast Asia Energy Outlook, 2017

### 1.2.5 CCT provides greater competitive edge for coal-fired power industry

The application of CCT is constantly improving. Thanks to advances in materials and process, efficiency of coal-fired power generation continues to increase, featuring application of high steam parameters and combined cycle technology. At present, the gross power efficiency of the most advanced high-efficiency coal-fired power units has exceeded 47% (LHV). The application of emissions control, especially the advanced technology of ultra-low emission, significantly reduces emissions of conventional pollutants from coal-fired power generation to below the limits of gas-fired power generation.

In terms of CO<sub>2</sub> emissions, improving energy efficiency to reduce coal consumption will also reduce total CO<sub>2</sub> emissions; developing and applying CCUS technology will reduce CO<sub>2</sub> emission intensity. At present, some CCUS projects are going through commercial demonstration; in the future, CCUS is expected to become more efficient with lower cost, thus making coal power cleaner.

### 1.2.6 CCT benefits sustainable development of global energy

There are two strategies in moving towards a clean, low-carbon, efficient and safe global energy: promoting clean non-fossil energy and promoting clean and efficient use of fossil energy. Developing CCT is clearly one of the key measures in the second strategy.

As more CCTs are developed and adopted (such as coal-fired power

generation featuring high temperature, pressure and capacity; emissions control and CCUS), coal-fired power is gradually transforming into a basic power source that is safe, clean, efficient, reliable and flexible, making great contribution to clean energy, prevention and control of coal-fired pollution.

A combination of cheap, abundant and reliable coal resources and clean technologies can maximize energy efficiency of coal, thereby saving resources, reducing pollution, securing energy supply, and even supporting the development of renewable energy such as wind and PV power. Developing efficient, clean, stable, safe and economical coal-fired power is conducive to sustainable economy development and the improvement of people's lives in Asia-Pacific region, especially for economies with rich coal resources.

## References

---

- [1] YAO Qiang(2005), Clean Coal Technology, Chemical Industry Press, Beijing, China.
- [2] YU Zhufeng(2004), The Application And Development Of Clean Coal Technology, Chemical Industry Press, Beijing, China.
- [3] Mehmet Melikoglu(2018), "Clean coal technologies: A global to local review for Turkey", Energy Strategy Reviews, Vol. 22.
- [4] APERC(Asia Pacific Energy Research Centre). Coal Report 2018, APERC, 2019.
- [5] HUANG Qili et al.(2014), Advanced coal-fired power generation technology, Science Press, Beijing, China.
- [6] National Energy Administration, China Electricity Council(2018), 2017 National Electricity Reliability Annual Report, National Energy Administration, China Electricity Council, Beijing.
- [7] IEA(2018), World energy outlook 2018, OECD/IEA, Paris.
- [8] Guo Juan, Li Weiming, Yao Xiaoyin(2015), "Supply and demand analysis of global coal

---

resource”, *China Coal*, Vol. 41(12), pp. 124-129.

[9] IEA(2018). *Coal Information Overview 2018*, OECD/IEA, Paris.

[10] IEA(2018). *Electricity Information Overview*, OECD/IEA, Paris.

[11] Zang Ningning(2018), “Re-examine the position and role of coal power in China's power system”, *Energy of China*, Vol. 40(6), pp.30-34.

[12] IEA(2017). *IEA Southeast Asia Energy Outlook, World Energy Outlook Special Report*, OECD/IEA, Paris

## **Chapter II Overview on the Global Development of Clean Coal Technology**

In the early 1980s, to solve the problem of acid rain on the border between the United States and Canada, the United States initiated Clean Coal Technology (CCT) <sup>[1]</sup>. CCT in the United States has always been at the forefront of the world. In 1986, the United States government took the lead in proposing the Clean Coal Technology Demonstration Program (CCTDP), which aimed to reduce the emission of traditional pollutants such as SO<sub>2</sub> and NO<sub>x</sub> in the power sector by developing and demonstrating advanced CCT which was environmental-friendly and with excellent operation performance and economic competitiveness. Economies such as the European Union and Japan also started to develop clean coal utilization technologies to solve emission problems caused by coal combustion and continuously improve the efficiency of coal-fired power generation.

In the past 40 years, great progress has been made in the development and commercial application of CCT. At present, the international community has solved the technical problems of traditional pollutants emissions such as dust, SO<sub>2</sub> and NO<sub>x</sub>. As low carbon development is becoming a global trend, many economies have paid more attention to the issue of CO<sub>2</sub> emission during coal utilization in recent years, and how to control CO<sub>2</sub> emission has gradually become a new highlight in CCT.

## **2.1 Clean and efficient coal-fired power generation technologies**

In order to continuously improve coal utilization efficiency, the international community has actively promoted the R&D and commercial application of SC/USC, CFB, CHP and other technologies.

### **2.1.1 SC/USC coal-fired power generation technology**

With increased main steam parameters, conventional coal-fired generating units have higher efficiency and lower coal consumption. After decades of development, SC and USC coal-fired power generation technologies have become the most mature and commercialized clean technologies at present, and have achieved remarkable results in energy saving and emission reduction in its wide application.

From the 1950s to the 1980s, economies represented by the United States, Germany and Japan began to develop SC/USC technologies. The world's first USC unit-Unit 6 of the Philo Power Plant in the United States--was put into operation in 1957 with a capacity of 125MW, a steam pressure of 31 MPa and steam temperature of 621 °C/566 °C/566 °C.

In the 1980s, the United States, Japan and Europe all launched new materials research and development programs. With the successful development of new materials, innovation of structure design and



technological improvement, the reliability problems encountered by earlier SC units have been gradually solved. The conventional SC technology has become increasingly mature and the units' cost-effectiveness, reliability and operational flexibility has been greatly improved. Subsequently, USC units were applied in large-scale internationally. The technology at this stage was represented by that of Japan (Mitsubishi, Toshiba and Hitachi) and Europe (Siemens, the former Alstom), and higher steam temperature and pressure was adopted while ensuring high reliability and high availability<sup>[2]</sup>.

At present, the USC units have entered a mature and practical stage, and the efficient coal-fired power generation technology represented by double reheat cycle has also been further developed. SC and USC power plants are mainly operated in China, US, Japan, Europe, Russia and other economies and regions<sup>[3]</sup>. By the end of 2017, China already had 103 sets of 1000MW USC units. At present, the steam parameters of USC units that are operated commercially can reach 28MPa(a)/600°C/620°C. For example, Taizhou Power Plant Phase II, which adopts USC double reheat technology, has a design gross power efficiency of 47.92% (LHV), gross coal consumption rate<sup>1</sup> of 256.28g/kWh, and steam parameters of 31 MPa/600°C /610°C/610°C (see 4.5.1 for details).

---

<sup>1</sup> Gross coal consumption rate: standard coal equivalent consumption per kilowatt hour power generation, 7000 kcal (LHV) per kg of standard coal equivalent.

To further reduce CO<sub>2</sub> emissions, power generation coupling coal and renewable energy (especially biomass) is regarded globally as one important measure to reduce coal-fired carbon emissions. There are now more than 150 sets of large-capacity power plants that co-firing biomass with coal for power generation in the world, mainly located in the European Union, the United States and Australia. The single unit capacity of coal-fired biomass power plants is usually 50-800MW<sup>[4]</sup> (including pulverized coal-fired boilers, grate furnaces, CFB, etc.). In recent years, China has also begun R&D and demonstration of co-firing biomass with coal for power generation.

### 2.1.2 Circulating Fluidized Bed (CFB) Power Generation Technology

CFB is an important clean and efficient coal-fired power generation technology due to its outstanding fuel flexibility, wide load adjustment range and convenient ash and slag handling. In the past 40 years, this technology has developed rapidly and been widely used in the world.

In the 1970s, the United States, Europe and Japan began the R&D of this technology one after another. In the 1980s, Lurgi GmbH from Germany applied for the first CFB patent. In 1979, the first 15MW commercial CFB boiler developed by Ahlstrom was put into operation in Pihlava, Finland. In 2002, the world's earliest 300MW CFB boilers were put into operation

in JEA Power Plant in the United States, which were designed and manufactured by Foster Wheeler, an American company. In the 1990s, boiler manufacturers began to devote a lot of energy to the R&D of SC CFB boilers. In June 2009, Lagisza Power Station in Poland using Foster Wheeler CFB technology was put into operation which is the world's first SC CFB project. The power plant had a total installed power capacity of 460MW, and its steam parameter was 27.5MPa/560°C/580°C<sup>[5][6][7]</sup>.

To further improve efficiency, the operation parameters of CFB are continuously improved and the capacity is continuously increased. In 2012, a 600MW SC CFB boiler was put into operation in China's Baima Demonstration Power Station, which has the largest single-unit capacity in the world (see section 5.7.1 for details). In 2017, Samcheok 4×550 MW USC CFB boiler of Korea Southern Power Co. began commercial operation with a designed steam parameters of 25.7 MPa/603°C/603°C<sup>[8][9]</sup>. Currently, 660MW USC CFB boilers are at the stage of R&D and demonstration. By the end of 2017, China's installed CFB power generation capacity has exceeded 100GW and thus became an economy with the most CFB boilers and the largest total capacity in the world.

In addition, the CFB technology also has great potential of being applied in poly-generation and the co-firing of biomass, coal slime, municipal waste and garbage, etc., and there were a number of demonstrations and

applications in the world. Poland, Finland and Republic of Korea all have cases of co-firing biomass by large-capacity CFB boilers <sup>[4]</sup>. These cases have not only expanded the technology's application scope, but also promoted the utilization of low heating value (LHV) fuels as resources, especially biomass and municipal waste, which plays a highly positive role in improving the comprehensive utilization of resources, energy conservation and emission reduction.

### 2.1.3 Integrated Gasification Combined Cycle (IGCC) Technology

The Integrated Gasification Combined Cycle (IGCC) adopts a gas-steam combined cycle, which improves the power generation efficiency of the whole system by cascade utilization of energy. The technology converts coal into syngas, which solves the problem of pollution emission control caused by coal burning. In addition, in terms of CO<sub>2</sub> capture and storage, IGCC adopts a pre-combustion capture technology route, which is more efficient than traditional coal-fired power units that use post-combustion capture, and is technically easier to deliver with lower cost. Therefore, IGCC has better power generation efficiency and environmental potential.

In 1984, the 100MW Cool Water demonstration project in California, US was the first IGCC plant in the world that was truly successfully operated. Its main purpose was to verify the reliability of IGCC. The successful

operation of this project gave rise to the first wave of IGCC construction and R&D, during which the gasifier technology, syngas purification technology and advanced gas turbine technology with a high temperature and pressure ratio developed rapidly.

Currently, the United States, Europe, Japan and China have all built their own IGCC demonstration power plants. Globally, IGCC power plants that have put into operation mainly include Buggenum in the Netherlands, Puertollano in Spain, Wabash River and Tampa in the United States, Negishi and Nakoso in Japan and China Huaneng Group Greengen Co., Ltd, etc. Among them, Tampa IGCC power plant in the United States has a total output of 315MW and a net output of 250MW. In this project, Texaco gasification process is adopted using coal-water slurry fuel, and the design net power efficiency is 42% (LHV), and the emission of major atmospheric pollutants such as particulate matters, sulfur, NO<sub>x</sub>, CO, volatile organic compounds (VOC) and mercury are effectively controlled. The investment cost of this project is about \$1900-2000USD/kW<sup>[10]</sup>. Generally speaking, the power supply efficiency of these stations is about 38-43% at present, among which the actual highest net power efficiency of Buggenum Power Station adopting Shell gasification technology is 43% (LHV)<sup>[11]</sup>. However, due to factors such as huge equipment investment, high power generation cost and lack of operation and debugging experience, IGCC is still at the demonstration stage and has not developed

into a technology that can compete with SC/USC coal-fired power plants.

In recent years, global warming caused by greenhouse gas dominated by CO<sub>2</sub> has become an important and pressing hot-spot issue facing mankind. Reducing and controlling CO<sub>2</sub> emissions in energy production and utilization is a major challenge in global energy production. Against this backdrop, IGCC power generation technology's high efficiency and its advantage in CO<sub>2</sub> capture have attracted wide attention. IGCC has become one important technical solution for reducing CO<sub>2</sub> capture costs and CO<sub>2</sub> emission. Most IGCC projects promoted around 2008 considered CO<sub>2</sub> capture and disposal issues<sup>[12]</sup>. After the first IGCC power plant was put into operation in China in 2012, a 60,000-100,000t CO<sub>2</sub>/year capture system was also built.

#### 2.1.4 Combined Heat and Power (CHP) Technology

CHP technology is highly efficient, and it has been widely used in industrial production and people's life, which brings the obvious benefits in energy saving and environmental protection.

In 1905, Britain manufactured the world's first CHP steam turbine unit. In 1907, Westing House manufactured a type of CHP unit with regulated extraction turbine, which could adjust the extraction pressure. Since then, due to the rapid industrial development, the demand for electricity and heat

has increased simultaneously, and CHP generation has more obvious advantages compared to separate generation of heat and power. With the introduction of incentives as supportive policies and diversified financial subsidies in many economies, the technology has developed rapidly in northern Europe, Russia and the United States <sup>[13]</sup>.

At present, natural gas, coal, oil and renewable energy have account for 53%, 36%, 5%, and 6% respectively in fuels used for CHP worldwide. According to statistics, the total installed capacity of CHP globally reached 755.2GW in 2016<sup>[14]</sup>, in which the Asia-Pacific region, represented by China, India and Japan, had the largest installed capacity, accounting for 46%. Europe is a traditional market of CHP, and its share of the installed capacity is about 39% (with that of Russia being relatively larger). And the Asia-Pacific region is the main growing market. With the CHP's advantages in environmental protection and energy efficiency, the Chinese government also started promoting its development and application. Driven by national policies, the proportion of CHP units in China has continuously increased, with the installed capacity scale in China reached 435GW by the end of 2017.

At present, in public heating supply, CHP has become public welfare infrastructure for urban pollution control and improvement of people's quality of life <sup>[15]</sup>. Centralized heat supply for people's livelihood or

industrial parks by CHP can replace a large number of scattered and inefficient small boilers, thus greatly reducing emissions and effectively improving regional environmental quality <sup>[16]</sup>.

## **2.2 Flue Gas Pollutant Control Technologies**

The United States Environmental Protection Agency (EPA) promulgated the *Clean Air Act* in 1970. Under the guidance of this Act, the United States issued the first emission standards for air pollutants from new sources of coal-fired power plants in 1970, which set emission limits for SO<sub>2</sub>, NO<sub>x</sub> and particulate matters in newly-built power plants. Since then, the standards have been continuously tightened <sup>[17][18]</sup>. The scope of pollutants has also been gradually extended to include PM<sub>2.5</sub>, SO<sub>3</sub> and heavy metals such as mercury. Europe and Japan also adopted an active reduction and control strategy, and imposed further limits on pollutant emissions from newly-built power plants<sup>[19]</sup>. With the introduction of policies and ever stricter emission standards, flue gas pollutant emission control technologies have developed rapidly and been widely used.

### (1) Dedusting

At present, coal-fired power plants mainly have adopt electrostatic precipitators (including dry precipitators, DESP and wet electrostatic precipitators, WESP), bag precipitator and electric-bag precipitator for



dedusting. Among them, wet electrostatic precipitators are mainly used for second-time dedusting after wet desulfurization process, which can effectively remove dust and particles generated in wet desulfurization process, and can also remove  $\text{SO}_3$ , mercury and its chemical compounds.

Currently, about 36% of coal-fired power units in the United States have adopted bag precipitators which are mainly used in the semi-dry desulfurization and multi-pollutant removal process. As of December 2015, electrostatic, bag and electric-bag precipitators accounted for about 70%, 8% and 22% respectively of the total capacity of coal-fired power units in China<sup>[20]</sup>.

## (2) Desulfurization

Flue gas desulfurization usually has three processes, i.e. wet process, dry process and semi-dry process. Among them, limestone-gypsum wet desulfurization is the most widely used technology that is sophisticated, and has strong adaptability to changes in coal types and power load, low operation and maintenance costs, and high desulfurization efficiency. Besides, its by-products can be sold, and  $\text{SO}_3$ , particulate matters and heavy metals in flue gas can also be partially removed.

In 2016, 78.9% installed units used the wet desulfurization process in the United States<sup>[21]</sup>, while the rest mostly used the spray dryer absorber (semi-

dry process). Most coal-fired power plants in Japan and China adopt the limestone-gypsum wet desulfurization process. In recent years, several coal-fired power plants in Japan have also begun to use the activated coke flue gas desulfurization technology.

### (3) Denitrification

Coal-fired power plants mainly use two NO<sub>x</sub> emission control technologies: one is low NO<sub>x</sub> combustion technology, which controls NO<sub>x</sub> generation in combustion through various technical approaches, which are mainly low NO<sub>x</sub> burners and air-staging combustion technology; the other is flue gas denitrification technology, which treats NO<sub>x</sub> generated in flue gas mainly by Selective Catalytic Reduction (SCR) and Selective Non-Catalytic Reduction (SNCR). At present, SCR is the most widely used, mature and effective flue gas denitrification technology in the world.

At present, low NO<sub>x</sub> burners have been widely used in coal-fired power plants in the United States, among which about 47% adopt the SCR technology<sup>[22]</sup>; In China, pulverized coal boilers of 200MW and above all adopt the low NO<sub>x</sub> combustion technology and SCR technology is mostly used in flue gas denitrification, accounting for more than 90% of the capacity of coal-fired power plants.

### (4) Mercury control technology

The mercury control technology includes mercury oxidation by modified SCR catalysts, adsorbents (such as activated carbon, modified fly ash, other porous materials, etc.) injection upstream of electrostatic precipitators, adding stabilizers in desulfurization towers, adding complexing agents into desulfurization wastewater, etc. Existing flue gas treatment facilities such as denitrification devices, precipitators and desulfurization devices in coal-fired power plants can also remove a certain amount of mercury in flue gas synergistically.

The United States leads the world in the development of flue gas mercury control technology in coal-fired power plants. At present, a lot of coal-fired power units in the United States have installed mercury control equipment using activated carbon injection systems.

#### (5) Ultra-low emission

In 2014, China put forward the concept of “ultra-low emission” for coal-fired power plants to meet the emission limit for gas-fired power generation (i.e. the emission concentration of dust, SO<sub>2</sub> and NO<sub>x</sub> should not be higher than 10mg/m<sup>3</sup>, 35mg/m<sup>3</sup> and 50mg/m<sup>3</sup> respectively under the basic condition of 6% O<sub>2</sub>), which was rapidly promoted and applied in China (seen Chapter 7 for details). No single technology is able to control the pollutants emission within certain limits, so to help coal power achieve ultra-low emission, a series of technologies must be systematically used.

The air pollutant emissions of some coal-fired power plants in Japan and the United States are close to its limits for gas-fired power generation using current desulfurization, denitration and dedusting solutions. The technical route adopted is generally the combination of SCR, high efficiency dedusting, high efficiency wet desulfurization and WESPs, e.g. Hekinan Power Plant in Japan, ELM Road Power Plant and Trimble County Power Plant in the United States and MPP3 Power Plant in Netherlands<sup>[23]</sup>.

### **2.3 Carbon Capture, Utilization and Storage (CCUS) Technology**

To cope with climate change and reduce greenhouse gas emission, economies, on the one hand have promoted the R&D and commercial application of SC/USC and other clean and efficient coal-fired power generation technologies; on the other hand, they continuously expanded the R&D and demonstration of such technologies as CCS/CCUS to reduce the carbon emission intensity in coal burning.

CCS/CCUS mainly includes CO<sub>2</sub> capture, transport, storage and utilization technologies. CO<sub>2</sub> capture technologies include post-combustion capture, pre-combustion capture and in-combustion enrichment (including oxy-fuel combustion and chemical looping combustion). At present, these technologies have all entered into commercial demonstration, except for chemical looping combustion, which is still in the development stage.

Post-combustion CO<sub>2</sub> capture removes CO<sub>2</sub> in flue gas discharged after combustion. At present, the amine-based post-combustion capture is the most developed of the CO<sub>2</sub> capture options. Canada's Boundary Dam Unit 3 is the world's first commercial scale post-combustion capture power plant, which started operation in 2014 and has an annual capture capacity of 1 million tons CO<sub>2</sub>.

Pre-combustion CO<sub>2</sub> capture is mainly used in IGCC and polygeneration systems based on coal gasification. The combination of IGCC and CCS/CCUS is one of the most promising directions at present. Most IGCC projects in recent years designed with CO<sub>2</sub> capture.

In-combustion enrichment represented by oxy-fuel combustion has been successfully applied in small-scale pilot projects, such as Germany's Schwarze Pumpe (30MW), Australia's Callide (30MW) and China's Huazhong University of Science and Technology Yingcheng 35MW oxy-fuel combustion test facility <sup>[24]</sup>.

The method for CO<sub>2</sub> transport mainly includes tankers, ships and pipelines, among which the transport of CO<sub>2</sub> via pipelines is considered the most economical and reliable method for large-scale and long-distance transport.

The captured CO<sub>2</sub> is usually stored in deep saline formations, deep unmineable coal seams or depleted oil and gas fields. In this aspect, CO<sub>2</sub>

Enhanced Oil Recovery (CO<sub>2</sub>-EOR, hereinafter referred to as EOR) is the most mature and valuable storage technology. CO<sub>2</sub> utilization technologies that have been developed in recent years include geological utilization, chemical utilization and biological utilization.

At present, economies such as the United States, Norway, Australia, France, and China have all carried out CCS demonstration projects, some of which have reached the commercial scale. By October 2017, there were 37 large CCS/CCUS integration projects<sup>[25]</sup> (each with a capture capacity over 400,000 tons/year) . Among them, 17 large-scale projects are in operation with a total CO<sub>2</sub> capture capacity of 30 million tons/year: 10 EOR projects in North America, 2 saline formation storage projects in Norway, 1 EOR project in Brazil, 2 EOR projects in the Middle East and 2 saline formation storage projects in North America. CCS/CCUS is also developing rapidly in China with several commercial demonstration projects successfully carried out.

CCS/CCUS technology is a vital technical solution for reducing CO<sub>2</sub> emission and achieving global climate goals. To realize the goal of keeping global temperature increase "well below" 2°C in the *Paris Agreement*, the international community needs to further speed up the R&D and commercial application of CCS/CCUS technology.

References

- 
- [1]YU Zhufeng(2004), The Application And Development Of Clean Coal Technology, Chemical Industry Press, Beijing, China.
- [2]XIA Fang(2007), “Study on the Key Technologies for Developing the USCT in China”, PhD diss., Harbin Engineering University.
- [3]XIONG Yangheng et al.(2011), “Analysis of operation performance assessment for 600MW and above level ultra-supercritical units”, Thermal Power Generatio, Vol. 40(04), pp.1-4+8.
- [4]MAO Jianxiong(2017), “Co-firing Biomass With Coal for Power Generation”, Distributed Energy, Vol. 2(05), pp.47-54.
- [5]ZHOU Xinglong et al.(2013),” Development And Research of Large-Scale Circulating Fluidized Bed Boiler”, Proceedings of the 2013 Annual Meeting of Chinese Society for Electrical Engineering, Chinese Society for Electrical Engineering, Chengdu.
- [6]YUE Guangxi(2003), “Development and application of circulating fluidized bed technology”, Energy Conservation and Environmental Protection, Vol. 12, pp.3-4.
- [7]ZHANG Yanjun(2009), “600MW Supercritical Circulating Fluidized Bed Boiler Design Key Technology Research”, PhD diss., Zhejiang University.
- [8]XIN Sheng-wei, HAN Ping, NIE Li, et al.(2017) “Research on Furnace Types and Key Technologies of Ultra-supercritical CFB Boiler”, Power System Engineering, Vol. 33(04), pp.1-4+8.
- [9]CAI Runxia, LV Junfu, LING Wen et al.(2016),” Development of supercritical/ultra-supercritical circulating fluidized bed boiler technology”, Electric Power, Vol.49(12), pp.1-7.
- [10]JIAO Shujian(2009), “Review and Prospect on Development of IGCC Technology”, Electric Power Construction, Vol. 30(01), pp. 1-7.
- [11]LI Zhen(2013), “Thermodynamic Performance Potential of IGCC”, PhD diss., Institute of Engineering Thermophysics, Chinese Academy of Sciences.
- [12]SUN Hao, SONG Zhenlong(2010), “Research and Application of Integrated Gasification Combines Cycle”, Electric Power Technology, Vol. 19(19), pp.39-43.
- [13]LIAO Chunhui(2014), “Research On Heating Sources Combination Optimization Of District Heating Systems With Combined Heat And Power Plants”, PhD diss., Harbin Institute of Technology.

- 
- [14]YANG Yongming(2018), “Analysis on the current situation of Global Cogeneration Development”, <http://news.bjx.com.cn/html/20180625/908255.shtml>.
- [15]Li Wei(2015), “Energy Analysis and Optimization Reform of Thermal Power with Cogeneration Heat”, PhD diss., East China Institute of Chemical Technology.
- [16]XU Ershu , SONG Zhiping<sup>2</sup> , LI Shukang(2001), “Development of Combined Heat and Power”, Information On Electric Power, Vol. 03, pp.8-10+18.
- [17]YUN Yaru et al.(2012), “Analysis and Comparative study of Air Pollution Control between China and Europe”, Environment and Sustainable Development, Vol. 37(04), pp.32-36.
- [18]SHENG Qing et al.(2011), “Comparison of the Air Pollutant Emission Standards of Coal-fired Power Plants between China, the United States and European Union”, Journal of Environmental Engineering Technology, Vol. 1(06), pp.512-516.
- [19]LONG Hui at al.(2018), “Standards and technical route selection of flue gas pollutants control from coal-fired power units in Europe and Japan”, Electric Power Technology and Environmental Protection, Vol. 34(01), pp.9-13.
- [20]Ministry of Ecology and Environment(2016), Guideline on Best Available Technologies of Pollution Prevention and Control for Thermal Power Plant(Draft for comments).
- [21]ZHANG Jianyu, Wang Hao(2018), “Environmental protection roadmap for coal-fired power plants in the US”, Electric Power Technology and Environmental Protection, Vol.34(01), pp.18-22.
- [22] EPA(2018). Coal-fired Characteristics and Controls: 2018, <https://www.epa.gov/airmarkets/coal-fired-power-plant-data>
- [23]Ministry of Ecology and Environment(2016), Preparation instructions: Policy on Technologies of Pollution Prevention and Control for Thermal Power Plant (Draft for comments).
- [24]IEA(2016), 20 Years of Carbon Capture and Storage, OECD/IEA, Paris.
- [25]Global CCS Institute(2017), Global Status Report 2017, GCCSI.



## **Chapter III Rapid Development of CCT Promoted by China's Clean Energy Policy**

Coal dominates the fossil fuel mix in China, as it is “rich in coal, poor in oil and gas”. Such resource endowment determines that coal has long accounted for about two thirds of China's total primary energy consumption. Addressing regional air pollution and carbon emission caused by heavy coal consumption in economic development has always been an important issue for the Chinese government to consider and face.

In response to climate change and the appearance of a “new normal” featuring medium-to-high speed growth, the Chinese government has put forward the concept of “innovative, coordinated, green, open and shared development”, which requires changing the development mode, accelerating the industrial restructuring, promoting the reform of energy production and utilization, advancing the energy revolution, building a modern energy system that is characterized by cleanness, low-carbon, safety and efficiency and tailored to China's situation, thereby realizing clean and low-carbon development. Some important aspects of this concept include controlling the total amount of energy consumption and reducing the energy intensity; optimizing energy mix, by promoting the large-scale development of hydro, renewables and other types of non-fossil energy, utilizing fossil energy, especially coal in a clean and efficient way, and

expanding the consumption market of natural gas; improving the efficiency and development of energy system, and enhancing the strategic capability for safeguarding energy security. With the strong support of state policies and led by scientific and technological innovation, China has continuously improved the CCT and built the largest clean coal-fired power supply system in the world.

### **3.1 China's macro policy supports the efficient, clean and low carbon development of energy**

Since the implementation of reform and opening-up policy in the 1980s, China's economy has gradually entered a stage of rapid growth and coal has become its main energy source. To adapt to the transformation of global energy resources towards efficient, clean and low carbon development and promote the coordinated development between economy and environment, and in view of problems in domestic economic development, such as insufficient supply of clean energy, worsening environmental problems and deterioration of regional ecological environment, the Chinese government has adjusted its macro energy policy several times and considered clean, efficient and low carbon development as an important direction, which is supported by its current state policy (see Figure 3-1 and 3-2, Table 3-1).

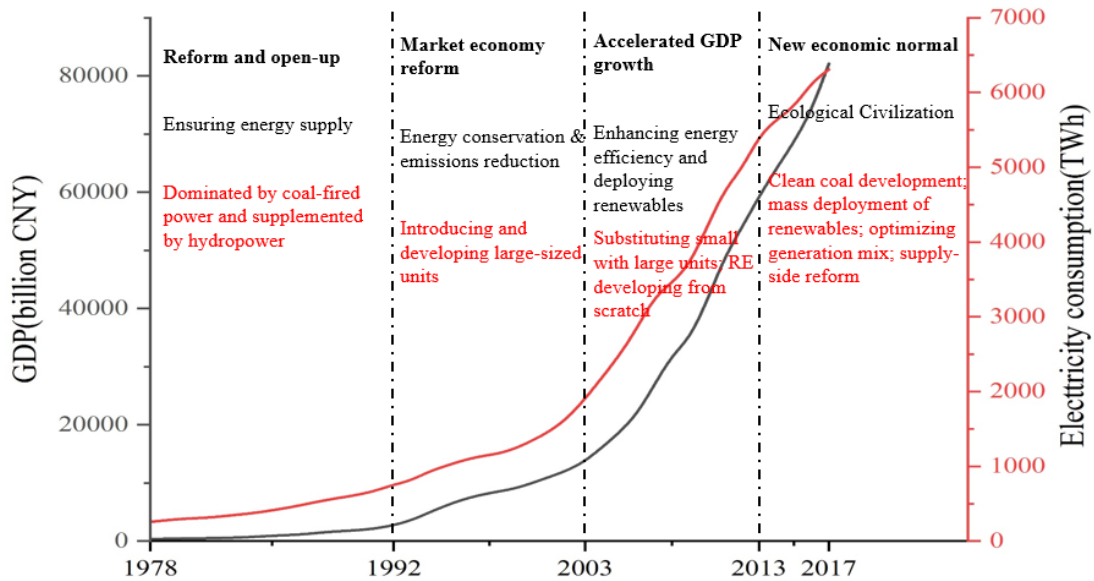

**Figure 3-1 The development history of China’s power industry from 1978 to 2017**

Source: National Bureau of Statistics

**Table 3-1 The evolution of China’s energy and power policy and mechanisms**

Period	Characteristics of energy economy	Characteristics of power policy
1979-1991	Began reform and opening-up and accelerated growth; increased energy-related construction and increased energy supply	Dominated by thermal power and supplemented by hydropower, with thermal power mainly generated by small-capacity units
1992-2002	Established a comprehensive market economic system; emphasized sustainable development, and implemented energy conservation and emission reduction policies	Fully guaranteed power supply; 72.8% of the newly built units were thermal power units; introduced and developed large-capacity units
2003-2012	High-speed growth, the power/energy elasticity coefficient reached the peak and then declined; made efforts to improve energy efficiency, reduced pollutant emission, and promoted the development of renewables	Implemented the policy “shutting down small-capacity units and building large-capacity units” for thermal power, significantly raised energy efficiency standards; non-hydro renewables starting from scratch
Since 2013	Economic development has formed a “new normal”; conserve ecological environment, strictly control total energy consumption, and strengthen clean and efficient utilization of coal and renewable energy development	Develop clean and high-efficient coal-fired power; actively develop large-scale renewables; optimize the power mix; supply side reform

Source: compiled by the author based on public information

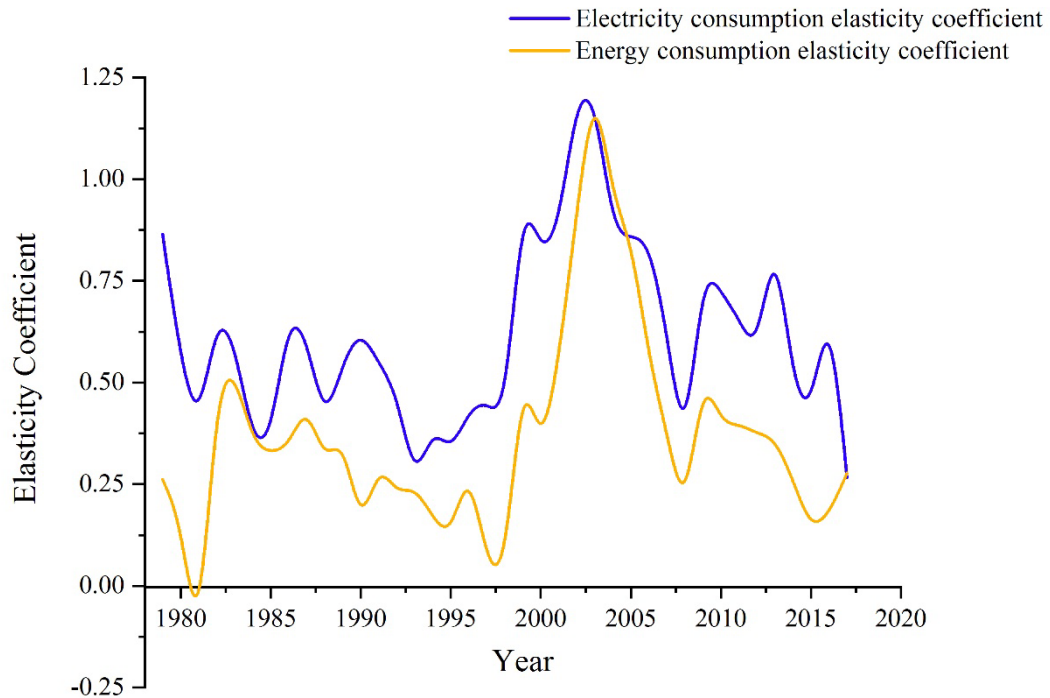

**Figure 3-2 The elasticity coefficients of China’s power and energy consumption from 1979 to 2017**

Source: National Bureau of Statistics, BP

At the beginning of reform and opening-up (1979-1991): China sped up economic development and replaced the heavy industry-oriented development strategy with the modernization strategy; required the enhancement of energy supply capacity and implemented the policy of “raising funds through multiple channels to build power plants” to alleviate power shortage. *The Environmental Protection Law of the People’s Republic of China* promulgated in December, 1989 requires the coordinated development between environment and economy. At that time, the power mix was dominated by coal-fired power and supplemented by hydropower, and coal-fired power was mainly generated by domestic

small-capacity units.

From 1992 to 2002: The focus of economic development gradually shifted from quantity-oriented to efficiency-oriented growth. China promulgated laws and regulations such as the *Energy Conservation Law*, *Electric Power Law* and *Energy Law*, which require equal emphasis on energy development and conservation <sup>[1]</sup>, and the power industry changed from “the combination of government function and enterprise management” to “the separation of government function from enterprise management”; further emphasis was placed on strengthening environmental protection, fully implementing the discharge permit system and raising the charging standard <sup>[2]</sup>. China began to require and encourage the development of CCT by introducing advanced technologies and large-capacity, high-parameter equipment, and the building of large-scale coal-fired power units. The contradiction between power supply and demand in China began to ease.

From 2003 to 2012: China entered a period of high-speed growth. It proposed to achieve green development and set more stringent and quantifiable targets on energy conservation and environmental protection: by 2010, the energy consumption per unit of GDP would be reduced by about 20% from that of 2005, and the total emission of major pollutants by 10% <sup>[3]</sup>. *The Renewable Energy Law* was promulgated and implemented in 2006. During this period, China carried out such measures as separating

power plants from power grids, entering the grid through bidding and energy conservation dispatching. While accelerating the development of renewable energy and encouraging diversified development of power, China also built on its own a large number of 600MW SC units and 600MW/1000MW USC units. So CCT was rapidly developed and applied in China. A policy of “shutting down small-capacity units and building large-capacity units” was implemented for coal-fired power to improve energy efficiency and reduce pollutant emission.

Since 2013: The economy has shifted from high-speed growth to medium-speed growth and formed a “new normal”. The Chinese government proposes to strengthen ecological conservation and low carbon development. *The Environmental Protection Tax Law* is implemented, and the pollution charges changed to the environmental protection tax; a new round of power system reform has begun. *The Strategic Revolution in Energy Production and Consumption (2016-2030)* requires that by 2020, the total amount of energy consumption be controlled within 5 billion tce and the proportion of coal consumption be reduced to below 58%; by 2020, China’s installed power generating capacity be 2000GW and that of non-fossil energy reach about 770 GW <sup>[4]</sup>. China also promises that its CO<sub>2</sub> emission will peak around 2030 and it will strive to reach the peak as early as possible; the carbon intensity of its GDP will be cut by 60% to 65% compared to 2005. During this period, driven by technological progress

and subsidy policies, its renewable energy has been developing at a high speed, with 229GW of wind and solar PV capacity added between 2013 and 2017 <sup>[5]</sup>; CCT is approaching the advanced world level. Electric power has gradually been diversified, covering renewable energy, coal-fired power, hydropower, nuclear power, etc. In this period, power surplus has occurred. The government has implemented the supply-side reform by raising the threshold for newly-built coal-fired power units, restricting the scale of newly-added coal-fired power, requiring the elimination of backward capacity (coal power units below 300MW) and the retrofit and upgrading of existing coal-fired power units for energy conservation and ultra-low emission.

## **3.2 State policy encourages the energy diversification**

### **3.2.1 Orderly control conventional power expansion**

As China's economy steps into the "new normal", the government has determined to cap the coal power and leave more space for sustainable energy transition. In the 13<sup>th</sup> FYP Power Sector Planning it is required to cap coal power capacity within 1100GW by 2020 <sup>[6]</sup>. To orderly control the construction of new coal-fired power plants, considering the economic return of coal-fired power projects, resource adequacy and environmental constraints, a risk warning index system for coal-fired power has been established since 2016. During the 13<sup>th</sup> Five-Year Plan period, a total of

150GW new coal-fired power projects has been halted or postponed, and another 20GW of existing coal-fired units with low efficiency and high pollution will be phased out [7]. Besides, in these key eastern provinces for air quality improvement, new captive coal-fired power projects are not allowed to approve and construct.

### 3.2.2 Vigorously promote renewables

To promote the development of renewable energy, the Chinese government promulgated the *Renewable Energy Law* in 2006 [8] and the *Medium- and Long-term Development Plan for Renewable Energy* in 2007 [9], after which it continuously enhanced the development goal of renewables. Policies have been successively promulgated to support the development of renewables, covering energy production, energy supply, technological development and environmental protection, and also including the total capacity target, classified subsidy system, special fund system, compulsory on-grid system and cost sharing system, etc. (see Table 3-2).

With the support of relevant policies, China’s renewable energy has developed rapidly. By the end of 2017, the installed capacity of wind power has reached 163GW and that of solar 130GW, which ranked the first in the world.

**Table 3-2 The overview of China’s renewable energy policies and mechanisms**

Supportive policy	Implications of policy
-------------------	------------------------



Total capacity target system	By 2020, non-fossil energy will account for 15% of the total primary energy; the installed power generating capacity will reach 770GW, and that of wind and solar PV will reach 210GW and 110GW respectively.
Classified subsidy system	Implement the feed-in tariff mechanism in renewable energy, which is adjusted as the industry develops; clarify the subsidy policy for distributed solar PV, and determine the benchmark price of solar-thermal power demonstration projects
Special fund system	Establish a renewable energy development fund, whose fund sources mainly include special funds and surcharges
Mandated on-grid system	Implement a full-scale guaranteed acquisition system for renewable energy, and dispatch thermal power units that shave the peak by renewable energy first
Cost sharing system	Clarify the imposition method and standard of surcharges, which increased from 0.002 yuan/kWh in 2007 to 0.019 yuan/kWh in 2016 after 5 adjustments.

Source: compiled by the author based on public information

### 3.2.3 Actively exploit hydropower

While accelerating the development of wind and solar PV, the Chinese government also attaches equal importance to the development of clean power such as hydropower, nuclear and gas. In 2017, the installed capacity of hydropower reached 341GW, accounting for 26.9% of the global total which has maintained a leading position in the world for long <sup>[6]</sup>. Meanwhile, the hydro capacity under construction is more than 48GW.

### 3.2.4 Prudently develop nuclear power

Initially, China's aggressive planning was to install 78GW of nuclear power by 2020. After the Fukushima nuclear disaster in Japan, China has revised the target to prudently build 58GW of nuclear power by 2020.

China’s nuclear capacity installation (35.8GW) and new capacity under construction ranks the fourth and first in the world respectively. With continuous efforts in developing nuclear industry, China has formed a complete industrial chain in design, equipment manufacturing, construction, safe operation and nuclear fuel cycle [10].

After decades of efforts, China today has been powered by a more diversified generation mix (see Figure 3-3 and Figure 3-4). The power structure has shifted from the combination of thermal and hydropower in the early days of reform and opening-up to the diversified development of coal, hydro, wind, solar PV, nuclear and natural gas currently. By the end of 2017, the installed power capacity of non-fossil energy reached 670GW, accounting for 37.8% of the total power capacity in China; the power generation reached 1863.1TWh, accounting for 29% of the total [5].

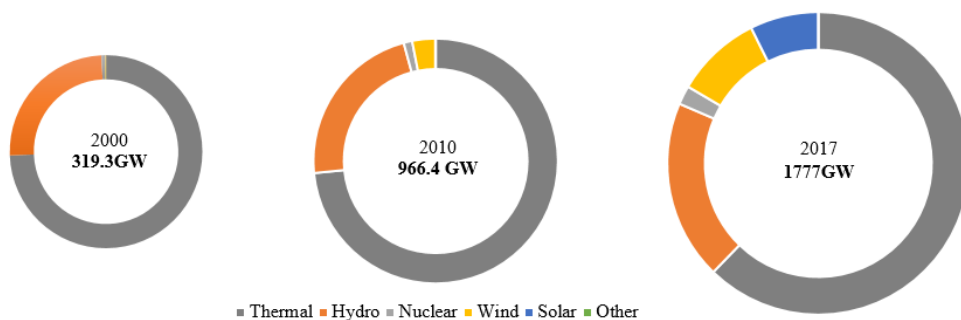

**Figure 3-3 The structural changes of China’s power generating capacity in 2000, 2010 and 2017 respectively**

Source: China Electricity Council

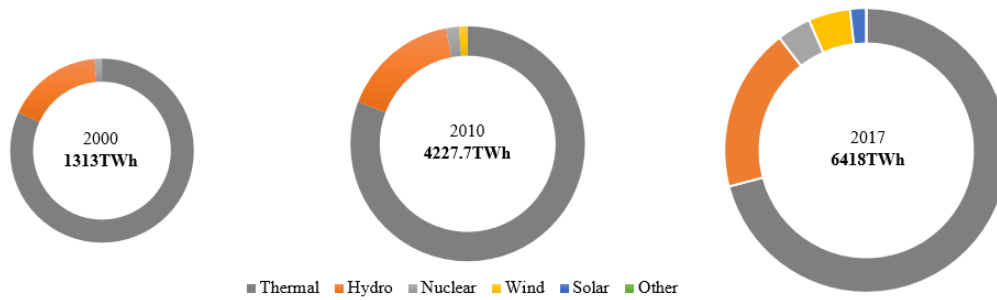

**Figure 3-4 The structural changes of China’s power generation in 2000, 2010 and 2017 respectively**

Source: China Electricity Council

China will endeavor to raise the clean and renewable power up to 50% of total power generation by 2030 <sup>[11]</sup>. It is predicted that China’s renewable increase in the next 20 years is likely to exceed the total of the EU and the United States <sup>[12]</sup>.

### **3.3 State policy promotes the rapid development of CCT**

To solve the problem of pollution caused by the inefficient use of coal in large amounts in many regions, the Chinese government has continuously elevated the requirements for green and low-carbon development, and considered renewable energy and other types of clean power as well as clean and efficient power generation technologies as two important orientations of sustainable power development. The National Development and Reform Commission (NDRC), Ministry of Ecology and Environment (MEE, originally Ministry of Environmental Protection, MEP), Ministry of Science and Technology (MOST), and relevant industry administrative

authorities are pressing ahead in this aspect jointly. While environmental protection standards are tightened continuously, a series of policies and industry management measures have been put in place to promote the development of clean and efficient coal-fired power generation technologies by technological guidance, dynamic planning, raising the threshold, upgrading and reconstructing active units within a time limit, issuing negative lists, and conducting environmental impact assessments.

### 3.3.1 Driven by innovation - accelerate the technological development for the clean coal utilization

China has increased investment in Research & Development (R&D) annually. From 2011 to 2017, China has made a total input of 45.87 billion yuan <sup>[13]</sup> in electric power R&D (see Figure 3-5), including the National Basic Research Program (973 Program), the National High-Tech R&D Program (863 Program), the National Key Technology R&D Program, the International Science and Technology Cooperation and Exchange Program, and the National Key R&D Program. Among the National Key R&D Programs approved in 2017, 21 were in the fields of clean and efficient utilization of coal and new energy-saving technologies, with a total research grant of about 500 million yuan <sup>[14]</sup>, such as “high-performance absorbents, materials and technologies for CO<sub>2</sub> capture”, “basic theory and key technology research on supercritical, efficient CO<sub>2</sub> coal-fired power

generation”, “coal gasification power generation technology with nearly-zero CO<sub>2</sub> emission”. Clean coal-fired power is also a direction with key support in the field of air pollution control technology.

Government departments, research institutes, universities and enterprises have facilitated joint R&D, formed a development and demonstration system of CCT, and promoted the technological progress and rapid development of the power industry, thus enabling China to stand in the forefront of CCT within just two decades.

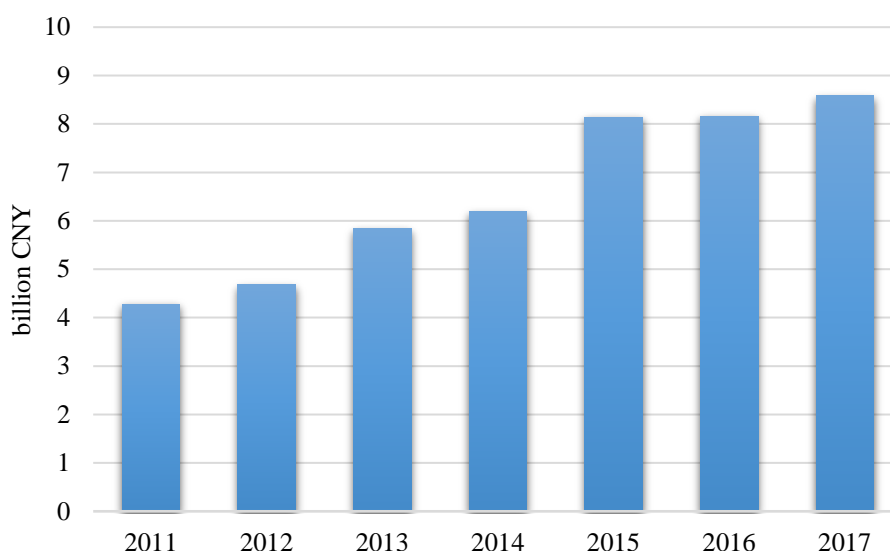

**Figure 3-5 Input of R&D from China’s Power Sector**

Source: *Statistical Report on Nationwide Science and Technology Expenditure (2011-2017)*, National Bureau of Statistics

### 3.3.2 Led by legislation - lead CCT development with laws and regulations

The Chinese government has gradually improved the clean energy

legislation system. The *Environmental Protection Law* (1989) aims to protect and improve the environment and encourage the preferential use of clean energy; the *Electricity Law* (1995) guarantees and promotes the development of power industry and adapts to the needs of national economy and social development; the *Coal Industry Law* (1996) aims for the rational development, utilization and protection of coal resources; the *Energy Conservation Law* (1997) promotes energy conservation and energy efficiency in the whole society; the *Cleaner Production Promotion Law* (2002) improves resource utilization efficiency and reduces or avoids the generation of pollutants; the *Renewable Energy Law* (2005) promotes the development and utilization of renewable energy to achieve sustainable economic and social development. China promulgates and revises energy-related laws to adapt to the changing economy and society, so as to guide the CCT development with a comprehensive legal system.

### 3.3.3 Standardized by norms - make strict standards on the air pollutant emission for coal-fired power plants

With the promulgation of increasingly strict limits on the emission of air pollutants for coal-fired power plants, China has been increasingly tough towards environmental protection (see Table 3-3).

**Table 3-3 The development history of air pollutant emission standards or requirements for coal-fired power plants**

Year	Name of standard (No.)	Emission limits of coal-fired power units
------	------------------------	---

		(mg/m <sup>3</sup> )		
		Dust	SO <sub>2</sub>	NO <sub>x</sub>
1973	Standard on the emission of three industrial wastes (in trial) (GBJ4-1973)	None	None	Irrelevant
1991	Emission Standards of Air Pollutants for Coal-Fired Power Plants (GBJ13223-1991)	600	None	Irrelevant
1996	Emission Standard of Air Pollutants for Thermal Power Plants (GBJ13223-1996)	200	1200	650
2003	Emission Standard of Air Pollutants for Thermal Power Plants (GBJ13223-2003)	50	400	450
2011	Emission Standard of Air Pollutants for Thermal Power Plants (GBJ13223-2011)	30 (20*)	100 (50*)	100
2014	Action Plan for the Retrofit and Upgrading of Coal-Fired Power Plants for Energy Conservation and Emission Reduction (2014-2020)	10 (5)	35	50

Note: \*Implement this standard in key areas, compiled based on public information.

In 1991, the first limit for dust emission was proposed, and various emission standards and limits were put in place for different types of dust removal facilities and corresponding coal ashes.

In 1996, nitrogen oxides were listed as pollutants for the first time, and new boilers were required to adopt the low NO<sub>x</sub> combustion measure. Dust emission standards were tightened, and new, expanded and reconstructed coal-fired power plants using medium and high sulfur coal were required to build desulfurization facilities.

In 2003, the limits for pollutant emission were further tightened and the flue gas of coal-fired power units was required to be desulfurized comprehensively.

In 2011, more stringent standards were implemented. The flue gas of coal-fired power plants not only needed to be desulfurized, but also denitrified; stricter and special emission limits were put in place for power plants in key areas; and Hg and its compounds were listed as pollutants for the first time.

From 2014 to 2020, ultra-low emission has been promoted throughout China. It is required that the emission of conventional air pollutants by new coal-fired power units should be close to the emission level of gas-fired units, and the retrofit for ultra-low emission among existing units should be completed by 2020.

At present, China is one of the economies that implement the most stringent standard for the emission of conventional pollutants from coal-fired power generation (Table 3-4).

**Table 3-4 Comparison of standards on air pollutant emission in major economies (mg/m<sup>3</sup>)**

Economies	SO <sub>2</sub>		NO <sub>x</sub>		PM	
	Active	New	Active	New	Active	New
China*	50	50	50	35	50	10
The EU	200-400	150-400	200-450	150-400	20-30	10-20
United States	160-640	160	117-640	117	23	23



India	200-600	100	300-600	100	50-100	30
Indonesia	750	750	850	750	150	100
Japan	-	-	123-513	123-513	30-100	30-100
The Philippines	1000	200	1000	500	150	150
Republic of Korea	286	229	308	164	40	20-30
Thailand	700	180	400	200	80-320	80
Viet Nam	1500	500	1000	650	400	200

Source:

China\*: *The Proposals for Comprehensively Implementing the Retrofit for Ultra-Low Emission and Energy Efficiency in Coal-Fired Power Plants*

Other economies: *World Energy Outlook Special Report 2016 Energy and Air Pollution*, IEA

### 3.3.4 Guided by planning - guide the quality development of coal-fired power plants through multi-tier planning

Featured by a cycle of five years, China's energy planning has an overall arrangement for the structure, development, production, conversion, utilization and distribution of energy. Based on the overall plan of the national economy and social development, and guided by the development plan of energy and power, the special energy planning has provided arrangements for renewables, hydropower, wind, solar, and power grids to lead the healthy and orderly development of the energy and power industry.

China's energy resources and load centers are unevenly distributed. Coal, wind, and solar resources are concentrated in the Northeast- North-Northwest Regions, and hydropower in the southwest region, while load centers are in the central and eastern regions, which are no longer suitable

for large-scale development of coal-fired power units as the requirements for ecological and environmental protection are increasingly strict annually. It is, therefore, necessary to promote the efficient development and utilization of clean energy. And in the planning and construction of power grids, power production bases should play a part in supporting the West-to-East Power Transmission Project.

By relying on 14 large coal bases and applying advanced energy- and water-saving and environment-friendly power generation technologies, China has built nine 10GW coal-fired power bases for outward transmission in Xilingol, Ordos, Northern Shanxi, Central Shanxi, Eastern Shanxi, Northern Shaanxi, Kumul, Eastern Junggar and Ningdong. As planned, the installed capacity of the nine coal-fired power bases would reach 263.93GW and have the full capability of supporting the West-to-East Power Transmission Project by 2020<sup>[15]</sup>. The cross-regional power grid system that supports the development of large-scale clean energy bases is increasingly improved, which bundles clean energy like wind and solar PV power with thermal power. Relevant policies, laws and regulations, and market mechanisms are also introduced to promote the cross-regional and cross-provincial consumption of clean energy.

The high quality development of coal-fired power was well formulated. Besides planning the layout of coal-fired power, strict requirements on the

energy efficiency and emission standards of new units have also been put forward as a guidance in applying advanced CCT. In accordance with the *Action Plan for the Retrofit and Upgrading of Coal-Fired Power Plants for Energy Conservation and Emission Reduction (2014-2020)*, by 2020, the installed capacity of coal-fired CHP units is aimed to account for 28% of the total capacity of coal-fired power. Low-Heating-Value (LHV) coal-fired power generation is developed in an orderly manner and the building of conventional coal-fired power generation projects in the name of LHV coal-fired power generation is prohibited. The retrofit towards ultra-low emission in the eastern, central and western regions is being steadily promoted <sup>[16]</sup>. China will continue to build an efficient, clean and sustainable coal-fired power industry.

The total capacity of coal-fired power plants was strictly controlled. In response to the gradual shift from power shortage to power surplus, the NDRC issued the *Opinions on Promoting the Supply Side Reform to Prevent and Solve Overcapacity in the Coal-fired Power Generation Industry* in 2017, which requires that the construction of 150 GW of coal-fired power generation should be halted or postponed during the Thirteenth Five-Year Plan period <sup>[17]</sup>. In 2017, China proposed “continuing the air pollution prevention and control action to win back the blue sky”, and specified that the building of captive power plants was prohibited in key areas for air pollution control such as the Beijing-Tianjin-Hebei Region,

the Yangtze River Delta and the Pearl River Delta.

3.3.5 Supported by industrial policy - formulate policies to raise the threshold for new units, retrofit and upgrade existing units, and eliminate backward capacity

Raise the threshold for new units. It is required that the average coal consumption for power supply of new coal-fired power units should be less than 300gce/kWh; newly built units of 600MW and above should apply USC steam conditions; CHP and CFB units of 300MW and above should apply SC steam conditions; new coal-fired power units should be equipped with advanced facilities for efficient desulfurization, denitrification and dedusting, and no flue gas bypass should be built <sup>[16]</sup>, thus effectively guiding the development and application of CCT.

Accelerate the retrofit and upgrading process of active units for energy conservation and environmental protection. To further reduce coal consumption and pollutant emission, active coal-fired power units are being retrofitted throughout China to reach the standard on atmospheric pollutant emission as required by local environmental protection needs: such units must be equipped with efficient desulfurization, denitrification and dedusting facilities; unqualified units must accelerate their retrofit and upgrading of environmental protection facilities to stably meet the emission requirement for full-load and full-time operation, in particular

under the minimum technical output. It is required that by 2020, the average coal consumption for power supply of active coal-fired power units should be less than 310g/kWh after their retrofit, among which that of units of 600MW and above (except air cooling units) should be less than 300g/kWh <sup>[17]</sup>. After the retrofit for ultra-low emission and energy conservation among coal-fired power units nationwide, 70 million tons of standard coal equivalent (tce) can be saved per year, CO<sub>2</sub> emissions reduced by 180 million tons per year, and the total emission of major pollutants in the power industry will be reduced by about 60% <sup>[18]</sup>.

Eliminate backward coal-fired power generation capacity. During the Eleventh Five-Year Plan period (2006-2010), China shut down 77GW of small units, which were all small coal-fired power units except for about 7 to 10GW oil-fired units; from 2011 to 2013, 10GW of small units were shut down <sup>[19]</sup>. During the Thirteenth Five-Year Plan period, a total of more than 20GW of backward capacity will be eliminated <sup>[17]</sup>, including units below 300MW that fail to meet the requirement for energy efficiency and environmental protection after the retrofit, condensing units in operation for 20 years and extraction condensing units in operation for 25 years. Coal-fired power units that fail to reach the minimum standard will be also shut down and phased out. It is estimated that 90 million tce will be saved per year after 110 GW of small units are shut down.

### 3.3.6 Readjusted for better functioning - retrofit coal-fired power plants for better flexibility retrofit so as to help stabilize the grid system and utilize renewable energy

It is required that coal-fired generation should serve as supportive power and boost the utilization of wind and solar power. In response to the unreasonable layout of renewable energy development and construction in the rapid development of electric power, the severe curtailment of wind and solar power in the Northeast-North-Northwest Regions, and the curtailment of hydro in the southwest region, the NDRC and the National Energy Administration (NEA) issued a series of policies from 2015 to 2017 to promote the consumption of wind and solar power. This includes adjusting the functional positioning of coal-fired power in the power system or shifting from an energy supplier to both an energy and a power supplier, i.e. taking SC and USC coal-fired power units featuring large-capacity, high-parameter, energy-efficient and low-emission as base load units, with subcritical units of 300-600MW providing flexible service; for units of 200MW and below with a long service life, those meeting energy efficiency and environmental protection standards will be retrofitted gradually to reserve and ancillary units, while those failing to meet the standards will gradually exit the market.

It is required to intensify the flexibility retrofit of CHP and condensing

units. Currently, the peak shaving capacity of China's condensing units is 50% (while the figure in Denmark and Germany is 80% and 60% respectively), and that of CHP units is only 20% (while the figure in Denmark and Germany is 80% and 60% respectively<sup>[20]</sup>). In response to this, it is required to promote the retrofit of CHP units for better heat storage and the flexibility retrofit of condensing units in northern regions, that is, improving their output range and their ability to respond to load changes or dispatching instructions. It is required that by 2020, 133GW of CHP units and 86GW of conventional coal-fired power units should be retrofitted respectively<sup>[6]</sup>; the minimum technical output of condensing units should reach 30% to 35% of rated capacity, and the minimum rating of CHP units should reach 40% to 50% of rated capacity<sup>[21]</sup>. This policy has played a positive role in improving the flexibility of units, and ensuring system stability and the integration of renewables. It is predicted that the flexible operation of thermal power units from 2018 to 2020 is likely to consume 66TWh of new-added wind power in total<sup>[20]</sup>.

### 3.3.7 Guaranteed by mechanisms - guide the coal-fired power industry towards clean and efficient development by economic incentives and regulatory constraints

Through the implementation of both mandatory energy conservation policies and eco-environmental policies, the government has adopted a

series of legal, policy and economic measures to promote the development of coal-fired power industry in a clean and efficient manner.

The market mechanism was adopted to encourage the clean and efficient operation of coal-fired power units:

(1) Implement energy-saving dispatching and green dispatching--in accordance with the principles of energy-saving, environment-friendly and economical and to ensure the reliable supply of power, clean energy power such as wind, solar, hydro, biomass and nuclear are dispatched preferentially and coal-fired power units should be dispatched based on their coal consumption level: those with a low level can generate power fully or even more power, while those with a high level generate less or no power at all. Gradually reduce the planned quota for coal-fired power plants and comprehensively promote the compensation mechanism of ancillary services. The ancillary service markets in Fujian, Shanxi, Gansu and other provinces have started formal operation.

(2) Balance energy efficiency and environmental protection when allocating on-grid electricity generation. The utilization hours of energy-saving and environment-friendly units should be appropriately increased. For example, Shanxi Province provides 100 hours of annual power generation as a reward for units that meet ultra-low emission standards <sup>[22]</sup>; Chongqing provides 200 hours (for units whose dust emission is below



5mg/m<sup>3</sup>, 250 hours are given) <sup>[23]</sup>; Jiangsu and Zhejiang also have similar incentives; for coal-fired power units whose air pollutant emission approaches or reaches the emission limit for gas units, their utilization hours are increased within a certain period of time. For example, Henan rewards such units with 200 hours of electricity generation in their annual basic planning.

The fiscal policy was used to encourage coal-fired power plants to improve their environmental protection level: For plants that meet the requirements for desulfurization, denitrification and dedusting facilities, the price of their on-grid power is increased by about 0.027yuan/kWh on average (the compensation for desulfurization is 0.015yuan/kWh, 0.01yuan/kWh for denitrification, and 0.002yuan/kWh for advanced dedusting) <sup>[24]</sup>. Among coal-fired power units that reach ultra-low emission levels, for active units that began operation before 1 January, 2016, the price of their on-grid power is increased by 0.01yuan/kWh; for new units that have been in operation after 1 January, 2016, the price is increased by 0.005yuan/kWh <sup>[25]</sup>. Shaanxi Province subsidizes units that have completed the retrofit for ultra-low emission based on a standard of 10yuan/kW <sup>[26]</sup>.

The energy conservation and emission reduction of active coal-fired power units were strengthened through industrial management and supervision mechanisms. The NDRC, MEE, NEA, industry associations and local

governments have worked together to supervise the energy conservation and emission reduction efforts of coal-fired power plants, including the operation of new units and the retrofit of active units. The environmental protection authorities are responsible for the environment protection acceptance, testing the emission level of air pollutants, and verifying the reductions of pollutant emission. Local administrative authorities assess the completion of energy saving and emission reduction tasks and announce the results to the public in a timely manner. For example, Guangdong Province has established a detailed list of pollution sources, gradually achieved automatic monitoring, and established mechanisms such as quality control, quality assessment and lab-based quality comparison, third-party quality control, and credit rating.

### **3.4 China has achieved remarkable progress in developing CCT**

The safety and reliability of coal-fired power units has increased significantly. The reliability level is measured by the annual evaluation of Generating Reliability Comprehensive Factor (GRCF). In 2017, a total of 1,756 coal-fired power units were included in the reliability assessment, with an installed capacity of 731GW, accounting for 74.5% of the total installed capacity of thermal power, with an average Equivalent Availability Factor (EAF) of 92.76%. In addition, the EAF of coal-fired

power units put into operation in 2016 reached 94.7%; that of SC coal-fired power units has increased, while the reliability of units of 300MW and below decreased slightly due to the year-on-year increase of planned and unplanned outage time<sup>[27]</sup>, as shown in Figure 3-6. The improved reliability of coal-fired power units is crucial for ensuring the safe operation of power grids and reliable supply of power.

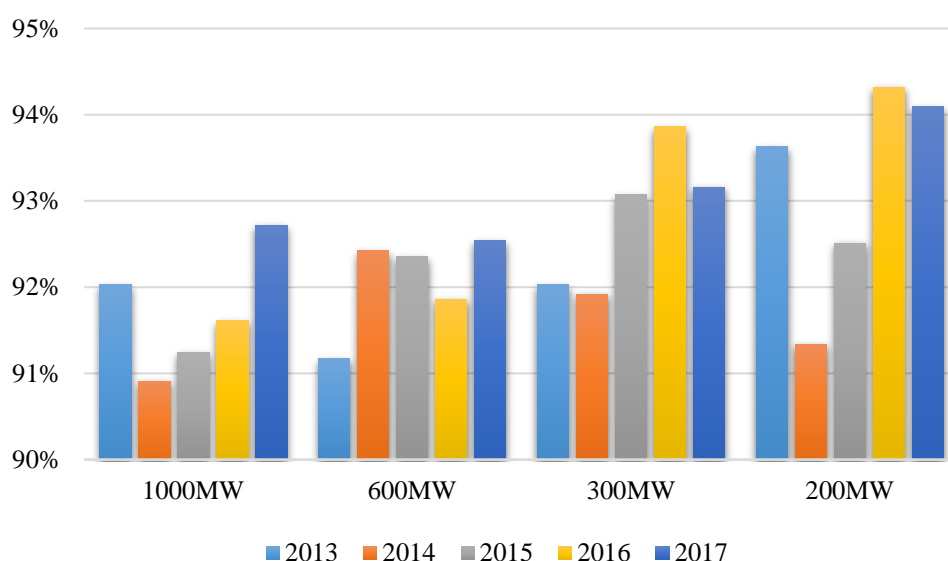

**Figure 3-6 The equivalent availability factor of coal-fired power units**

Efficient and low-pollution SC/USC units have become the mainstream units. Over the past three decades, China's coal-fired power generation technology has leaped from SC to USC. After constructing large-capacity, high-parameter (SC/USC) coal-fired power units and shutting down small and backward units, the proportion of SC and USC coal-fired power units reached 42% in 2016, the structure of installed power generating capacity was optimized, and the efficiency of power generation improved, which

was higher than that of Germany, the United States and Australia, and basically equal to that of Japan (see Figure 3-7) [28].

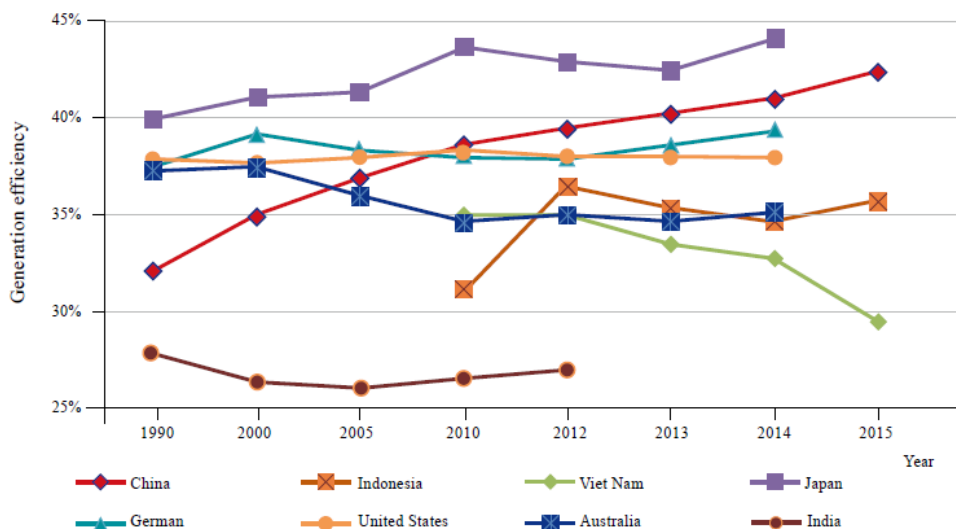

**Figure 3-7 The efficiency of coal-fired power generation in different economies (LHV)**

Source: China Electricity Council, IEA

In the early days of China’s reform and opening-up policy in the 1980s, the most advanced coal-fired power units were a very small number of 200MW units. At present, a power generation system dominated by large, domestic units of 300MW, 600MW and 1000MW has been formed. In the end of 2006, the first 1000MW coal-fired unit was put into operation in China; by 2017, the number became 103; at the end of the same year, the capacity of coal-fired power units of 1000MW and above accounted for 10.2% of the total installed capacity of thermal power; units of 300MW, 600MW and above accounted for 34.7% and 34.5% of the total installed capacity of thermal power respectively (see Figure 3-8) [28].

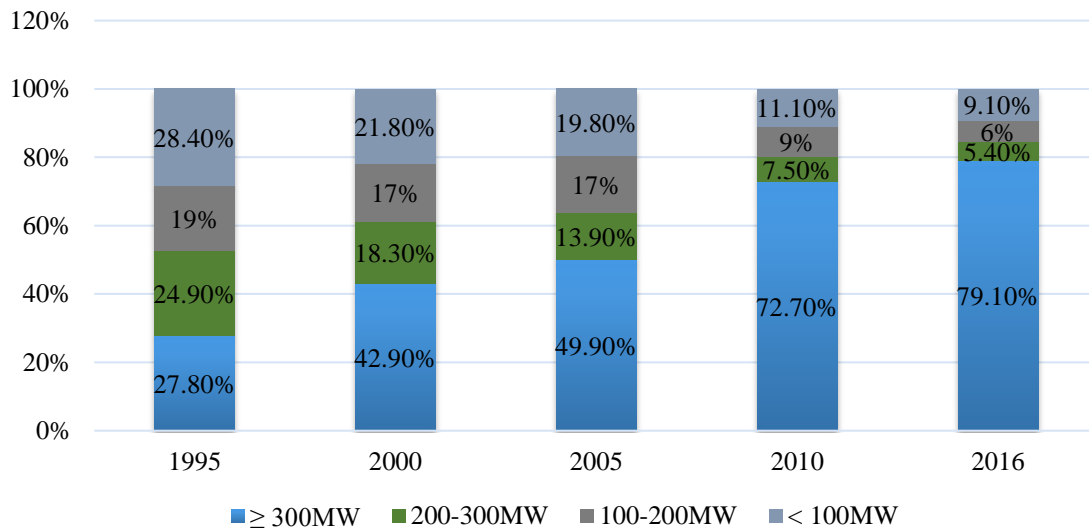

**Figure 3-8 The structure of coal-fired power units in China**

Source: China Electricity Council

The average coal consumption for power supply in coal-fired power plants has dropped significantly (Figure 3-9) and the average efficiency of coal-fired power units has been increasing. The operation of a large number of USC units has markedly reduced the coal consumption of coal-fired power units in China<sup>[10]</sup>. In 2018, the standard coal consumption for power supply of coal-fired power plants (6MW and above) in China was 308gce/kWh, a decrease of 34.6% compared with 471gce/kWh in 1978<sup>[29]</sup>.

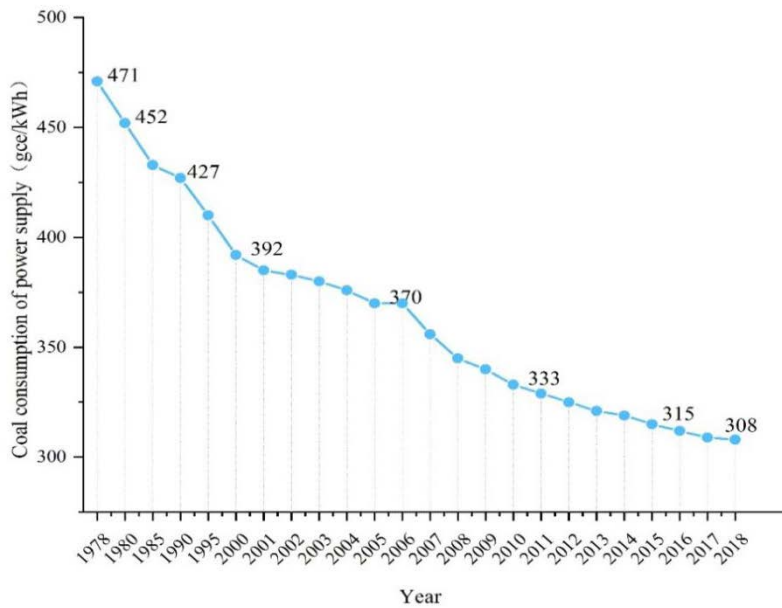

**Figure 3-9 The coal consumption for power supply in China from 1978 to 2018**

Source: China Electricity Council

More than 75% of coal-fired power units have completed the retrofit for ultra-low emission and 70% coal-fired power units completed the retrofit for energy conservation. As of 2018, China’s coal-fired power plants have completed the retrofit of more than 700GW in total for ultra-low emission and the retrofit of 650GW for energy conservation, which over-fulfilled the retrofit plan [30].

It is estimated that the reduced emissions of SO<sub>2</sub> and NO<sub>x</sub> by coal-fired power plants after the ultra-low emission retrofit are 29% and 47% of the total emission reduction in the past five years respectively [31]. The emissions of dust (particulate matter), SO<sub>2</sub> and NO<sub>x</sub> for per unit of power generated decreased from approximately 26, 10, and 3.6g/kWh (estimated by the author) respectively in 1978 to 0.06, 0.26 and 0.25g/kWh

respectively in 2017.

The carbon intensity for per unit of power generated by coal has decreased by one third. In accordance with China Electricity Council (CEC), the carbon intensity of China's total power generation and that of thermal power in 2017 were about 598g/kWh and 843g/kWh respectively, a decrease of 35.7% and 44.8% respectively compared with those of 1978. The carbon emission levels were lower than those of the United States, Germany, Canada, France, UK and other economies (see Figure 3-10) [28]. From 2006 to 2017, China's power industry has reduced about 11.3 billion tons of CO<sub>2</sub> emissions on an accumulative basis after developing non-fossil energy and improving energy efficiency. Specifically, the increased efficiency of coal-fired power generation contributed to 45% of CO<sub>2</sub> emission reduction, and the development of non-fossil energy contributed to 53% [32].

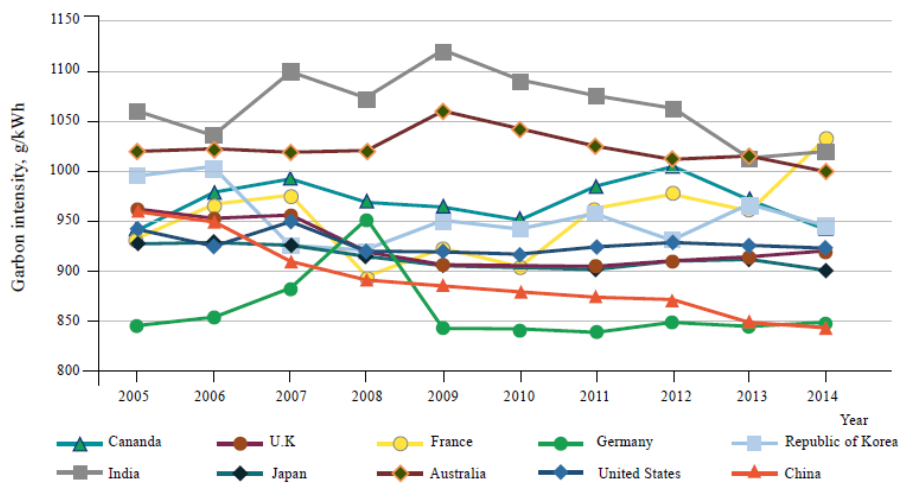

**Figure 3-10 The carbon intensity of coal-fired power generation in different economies**

Source: China Electricity Council

CCT is developing more diversified in China, including coal preparation, coal briquettes, coal water slurry (CWS), SC/USC coal-fired power generation, advanced burners, CFB combustion, IGCC, flue gas purification, coal gasification, coal liquefaction, fuel cells, etc., and a complete industrial chain of CCT has formed. In the field of CCT, SC/USC units, CFB units and poly-generation technologies have been applied in large-scale commercially in China; technologies such as double reheat at 630 °C , USC CFB boilers, power generation that couples coal and renewables are at the demonstration stage; technologies such as materials application at 700°C , CCS/ CCUS are at the R&D or demonstration stage. These diversified technologies has laid a foundation for the development of higher-parameter, higher-efficiency and more environment-friendly coal-fired power generation technologies in the future.

The rapid development of power industry has supported China's economic development. China's installed power capacity and generation increased from 57.12GW and 256.6TWh in 1978 to 1777GW and 6420TWh in 2017 respectively, increasing by 30 times and 24 times respectively <sup>[5]</sup>. In particular, the operation of a large number of 600MW, 1000MW SC and USC units enabled China's installed thermal power generating capacity to rapidly increase from 237.54GW in 2000 to 1104.95GW in 2017 <sup>[33]</sup>. Within just over one decade, China has solved the problem of power



shortage, and sufficient power supply has supported its rapid social and economic development. The development of USC technologies has also driven the technological development of metallurgy, machinery, environmental protection, and automatic control industries in China. China has evolved from an importer of power generating units to one of the world's largest exporters of coal-fired power units.

---

## References

- [1] State Council, People's Republic of China (PRC). China's Agenda 21 [Z]. 1994.03
- [2] Zhang Lianhui, Zhao Lingyun. Historical Evolution of China's Environmental Protection Policy from 1953 to 2003 [J]. Research on China's Economic History, 2007(4): 63-72
- [3] State Council, PRC. Outline of the Eleventh Five-Year Plan for National Economic and Social Development of PRC[Z]. 2005.10
- [4] National Development and Reform Commission (NDRC), National Energy Administration (NEA). Energy Planning for the 13th Five-Year Plan [Z]. 2016.12
- [5] Data collation from China Electricity Council (CEC)
- [6] National Development and Reform Commission. Electric Power Development for the 13th Five-Year Plan[Z]. 2017.06
- [7] NDRC, NEA, et al. Opinions on Promoting Structural Reform of Supply Side to Prevent and Resolve the Risk of Overcapacity of Coal Power [Z]. 2017.7
- [8] State Council, PRC. Renewable Energy Law [Z]. 2006.01
- [9] NDRC. National Renewable Energy Long-Term Planning [Z]. 2006.11
- [10] NDRC. Nuclear power industry medium and long-term development plan (2005-2020) [Z]. 2007.10
- [11] NDRC. Energy Production and Consumption Revolution Strategy (2016-2030) [Z]. 2016.12
- [12] Yang Kun. Analysis and Prospect of Electric Power Development of China in 2018 [J]. China Power Enterprise Management, 2018(10): 10-13
- [13] National Bureau of Statistics. Statistical Bulletin of National Science and Technology Funds Input (2011-2017)
- [14] Ministry of Science and Technology, PRC. List of National Key R& D Program Projects in 2017 [EB/OL]. 2017.06
- [15] Wang Shan. Understanding National Power Base Planning! [EB/OL]. International Energy Network, 2017.09

- [16] NDRC, Ministry of Ecology and Environment, NEA. Actions for Upgrading and Retrofit of Coal-Fired Power Plants for Energy Conservation and Emission Reduction (2014-2020) [Z]. 2014.09
- [17] NDRC, NEA. Opinions on Promoting Structural Reform of Supply Side to Prevent and Resolve the Risk of Overcapacity of Coal Power [Z]. 2017.08
- [18] State Council, PRC. Action Plan for the Prevention and Control of Air Pollution [Z]. 2015.12
- [19] Zhang Shuwei, Chen Xiaojuan. Comprehensive Assessment of the Policy of “substituting small with large units”[EB/OL]. Energy Economic Network, 2014(09):64-66.
- [20] Analysis on Peak-shaving Trend of China's Thermal Power Units in 2018 [EB/OL]. China Industrial Information Network, 2018.04
- [21] NEA. Notice on the Pilot Projects for Flexibility Retrofit of Thermal Power[Z]. 2016.07
- [22] The People’s Government of Shanxi Province. Shanxi Provides 100 Hours of Annual Power Generation Award to Units Meet the Ultra-Low Emission Standard [Z]. 2015.10
- [23] Standing Committee of Chongqing Municipal People's Congress. Suggestions on Formulating and Implementing the Award Policy for Ultra-Low Emission of Coal-fired Units in Chongqing [Z]. 2015
- [24] Wang Zhixuan. Renovation and New Historical Mission of Coal Power during the four decades [J]. Observation on New Energy Economy and Trade, 2018(09): 18-22.
- [25] Ministry of Ecology and Environment, NDRC, NEA. Fully Implementing the Work Program of Ultra-Low Emission and Energy Conservation Renovation for Coal-fired Power Plants [Z]. 2015.12
- [26] Jia Kehua. Enhancing Ultra-low Emission Renovation of Coal Power Intensively to Promote Energy Conservation and Emission Reduction[EB/OL]. China Energy Daily, 2015.12
- [27] NEA, CEC. Annual Report of National Electric Power Reliability in 2017 [R]. 2018.05
- [28] CEC. Report on Clean Development of Coal Power in China[R]. 2017.09
- [29] Wang Zhixuan. Current Situation and Prospect of Energy Conservation in China's Electric Power Industry[J]. Energy of China, 2017, 39(05):13-17+20
- [30] Wang Yichen. Over 700GW of ultra-low emission retrofit has been completed for coal-fired power units in China. [EB/OL]. Economic Daily, 2019.02
- [31] Yu Xuehua. Large-scale clean utilization of coal in power generation [EB/OL]. China Electric Power News Network, 2018.12
- [32] CEC. Summary of China’s Electric Power Development in 2017 [EB/OL]. 2018.06
- [33] National Bureau of Statistics. China Statistical Summary in 2018 [M]. Beijing: China Statistics Press, 2018.

## Chapter IV SC and USC Coal-fired Power Generation Technology in China

Currently, USC power generation technology is the most efficient and cost-effective conventional coal-fired power generation technology worldwide. The combination of USC power generation technology and environmental protection technologies enables coal-fired power generation to be environmental-friendly and cost-friendly, and with advantages of HELE (high efficiency and low emission). It is the most widely used and proven clean power generation technology.

### 4.1 Development Background

The development and application of USC coal-fired power generation technologies in China involve the following three periods:

#### **I. Exploration period: (from 1990s to 2004):**

In 1990s, Shanghai Shidongkou No. 2 Power Plant imported China's first 600 MW SC unit. Subsequently, in 2000 and 2004, the imported 800MW SC unit of Suizhong Power Plant and 900 MW SC unit of Shanghai Waigaoqiao No. 2 Power Plant were commissioned one after another, as shown in Table 4-1. Importing the world's leading SC main machine equipment is significant for China's utilities to know, understand and master SC technology.

**Table 4-1 The SC Units Imported**

Project	Unit Capacity	Unit Parameters	Commission Time
Shidongkou No.2 Power Plant	2×600MW	24.2MPa/538°C/538°C	1992
Suizhong Power Plant	2×800MW	23.5MPa/540°C/540°C	2000

Waigaoqiao No.2 Power Plant	2×900MW	24.2MPa/538°C/538°C	2004
-----------------------------	---------	---------------------	------

## II Rapid Development Period (2003-2010):

In 2003, Ministry of Science and Technology (MOST) in China launched a series of scientific and technological research and development projects such as the 863 Program “Research on USC Coal-fired Power Generation Technology”, gearing up for research on SC and USC coal-fired power generation technology in many aspects, including roadmap decision on SC/USC technology specifications, R&D on the key technology of boiler, turbine, and flue gas cleaning, study on power station engineering and operation, selection of high temperature resistant materials. Under the leadership of the MOST and the former State Power Corporation, USC power generation technology has become full-fledged as the result of cooperation among industrial companies, university, research institutes and utility companies. See Table 4-2.

**Table 4-2 Development Mechanism of USC Power Generation Technology in China**

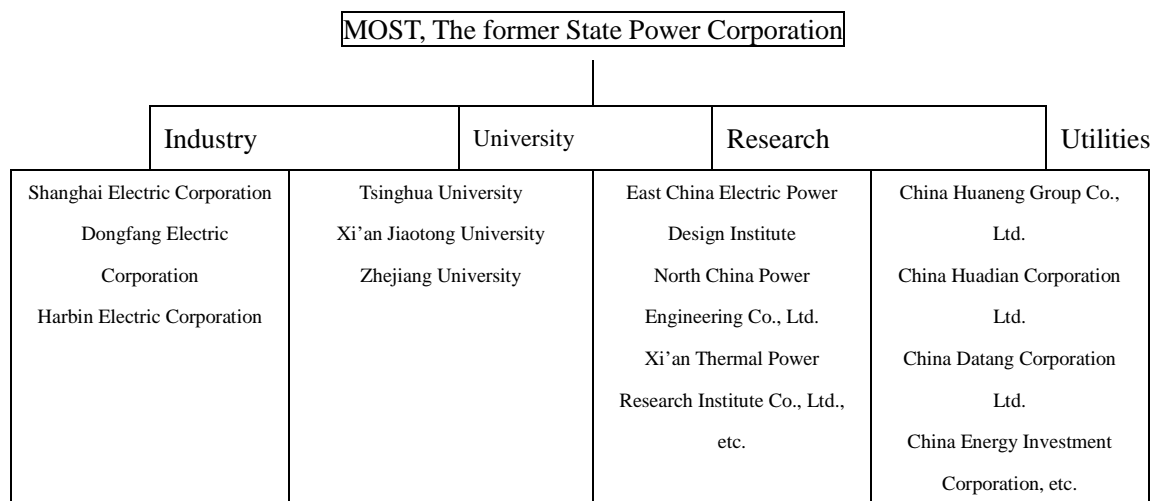

In 2004, China’s first domestic-made 600MW SC units (the parameters of 24.2MPa/566°C/566°C) were commissioned in Huaneng Qinbei Power

Station. In 2006, China's first 1000MW USC unit (26.25MPa/600°C/600°C) was commissioned in Huaneng Yuhuan Power Station. According to the performance of years of operation, in these units, expected technical performance has been achieved, and their operations are reliable.

Since 2006, a group of SC/USC units with capacity above 600MW-class were commissioned in China. Various problems occurred in operation were all solved successfully on time via continuous technical retrofits. Thus, China gained much experience for the development and utilization of SC/USC technology. During this period, SC/USC technology developed rapidly in China, mainly in the following aspects.

(1) SC/USC coal-fired power units are increasingly adaptable. China has developed a series of SC/USC units of various capacities, parameters and cooling system to adapt to meet various electricity demands, parameters hydrographic and meteorological parameters in different areas of China, as shown in Table 4-3.

(2) These units are obviously more efficient and reliable. Constant innovation and optimization of the design for each SC/USC power plant mechanism have driven their investment costs significantly lower, their efficiency and reliability remarkably higher, and their adaptability to the power grid stronger.

**Table 4-3 Diversified SC/USC Technologies Developed in China**

Items	Technical Features	Comments
Unit Capacity series	350MW SC, 600MW SC, 660MW USC, 1000MW USC, 1200MW USC	The 1200MW USC unit is of the largest USC unit currently in the world.
Unit Parameter	Range from the SC parameters of 24.2MPa/538 °C /566 °C to the USC	The unit of the highest parameters in the world operates in China.

	parameters up to 28MPa/600°C/620°C.	
Cooling Mode	Wet-cooling, Direct air-cooling and indirect air-cooling	China's 1100MW direct air-cooling unit and 1000MW indirect air-cooling unit are the largest ones with air-cooling system in the world.

(3) Remarkable achievements have been made in energy conservation and emission reduction. The designed net power efficiency of single-reheat USC units has increased from 43.3% (LHV) of the first-generation USC units to up to 45.4% (LHV) currently, and the emission of flue gas pollutants has matched the leading international standard.

(4) The design, manufacturing and construction capacities of SC and USC units are rapidly formed and enhanced. Since China's first domestic-made SC unit was commissioned in 2004, more than 300 domestic-made SC units have been commissioned in just over ten years, marking the highest growth rate in the world.

### **III The period for R&D and demonstration of advanced USC technology (2012-the next 15 years):**

The main development directions of China's advanced USC technologies are illustrated as follows:

- (1) Double-reheat unit. The development and application of USC double-reheating technology is widely and continuously practiced in China. Among them, Taizhou Phase II Project, which is invested by China Energy Investment Corporation, employs two sets of 1000MW double reheat units with the parameters of 31MPa/600°C /610°C/610°C, beginning to be constructed in 2012 and completed in 2015. It is a national demonstration project of USC double-

reheating technology, realizing complete independent design, manufacturing, and construction by Chinese companies. The success of the USC double-reheating units indicates that the USC coal-fired power generation technology has led the world.

(2) R&D has been carried out for advanced USC (AUSC) technology with higher parameters. “National 700°C USC Coal-Fired Power Generation Technology Innovation Consortium” was established in 2011. According to the plan, this consortium will carry out technical research and application on AUSC in terms of overall design of AUSC power plants, development and verification tests of high-temperature-resistant materials, including large-scale castings and forgings, key technologies of boilers and steam turbines, and construction of demonstration power plants. It is estimated that AUSC units parameters of 650°C and 700°C will be commissioned in 2025 and 2035 in China respectively.

(3) Research on the flexibility of coal-fired power units is being accelerated. As the installed capacity of wind and solar power generation in China’s power grid increases remarkably, thermal power units need to be more adaptable to the fluctuation of grid load and meet the practical requirements of thermal electrical decoupling of CHP units in Northern China. In 2016, China established the “China Thermal Power Flexibility Collaboration Platform”. This platform aims to convene international agencies, domestic power generation utility groups, power grid utilities

groups, design institutes, universities and research institutes to study the technical roadmap, market mechanism, and grid dispatching and operation mechanism to improve the flexibility of coal-fired power units and thermal electrolytic de-coupling.

## 4.2 Major SC/USC Power Generation Technologies

### 4.2.1 Parameter Series of SC/USC Units

China has developed and operated a series of SC/USC units. Their main parameters are shown in Table 4-4.

**Table 4-4 Turbine-inlet Parameter Series of SC/USC units**

Category	Main steam pressure (MPa)	Main steam/reheat steam temperature (°C)	Main steam flow (t/h)	Unit capacity level (MW)
SC single-reheat	24.2	538°C/566°C 566°C/566°C	1000~3000	350, 600, 660
USC single-reheat	25	600°C/600°C	>1800	600, 660, 1000
USC single-reheat	27.25	600°C/600°C	>1800	600, 660, 1000
USC single-reheat	28	600°C/620°C	>1800	660, 1000, 1200
USC double-reheat	31	600°C/610°C/610°C	>1800	660, 1000
USC double-reheat	31	600°C/620°C/620°C	>1800	660, 1000, 1300

Within a certain range, the temperature of main steam has limited influence on the volume flow rate and the efficiency of the flow passage in the steam turbine. However, the increase of the inlet steam temperature may drive up the thermodynamic cycle efficiency. To put it simply, each 10°C increase of superheated steam temperature causes a decrease of turbine heat rate by 0.25%-0.30%; each 10°C of reheat steam temperature causes about a heat consumption margin of 0.16%-0.20%. Under the precondition of constant boiler efficiency, turbine heat rate will directly affect the thermal efficiency



of the whole power plant. Therefore, increasing the inlet temperature of turbine is remarkably effective on improving the unit's thermal efficiency. Compared with increasing steam temperature, increasing the pressure is not as effective on improving the thermal efficiency of the unit. When increasing the main steam pressure, if the main steam pressure is lower than 30MPa, the thermal efficiency of the unit has a larger increase margin; while when the temperature is higher than 30MPa, the increase in efficiency is smaller.

Figure 4-1 and 4-2 respectively demonstrate the relationship between steam temperatures, steam pressures and thermal efficiency of a certain type of single-reheat and double-reheat unit respectively.

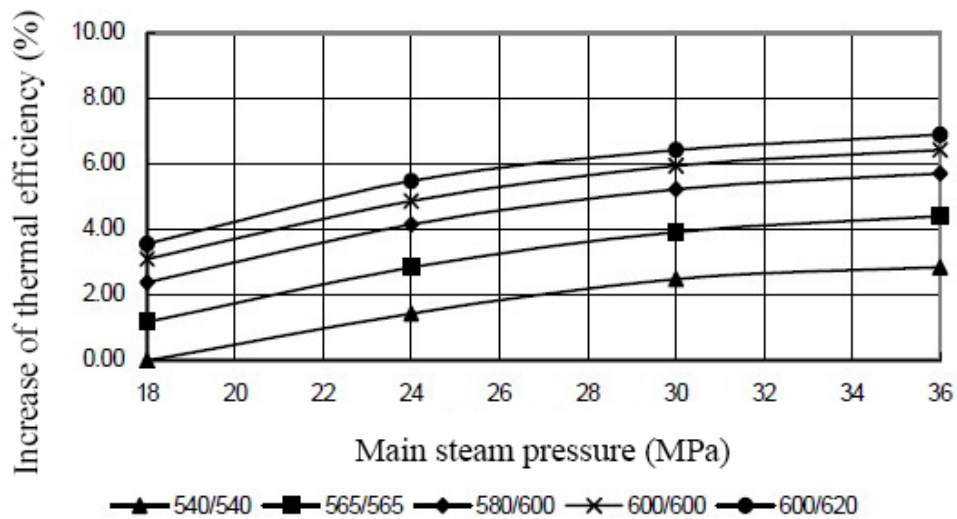

**Figure 4-1 Relationship between Steam Temperature, Pressure and Thermal Efficiency of a Single-reheat Unit**

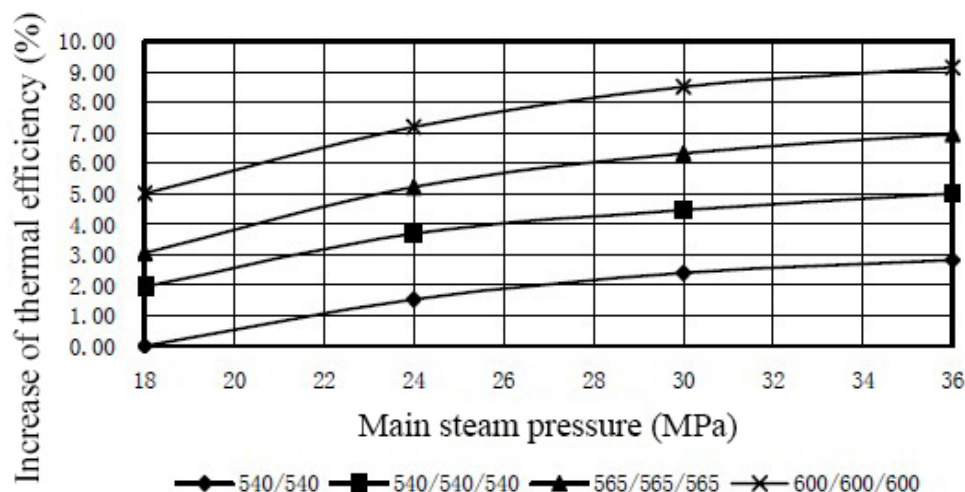

**Figure 4-2 Relationship between Steam Temperature, Pressure and Thermal Efficiency of Double-reheat Unit**

#### 4.2.2 Technical Features of SC Units

The fleet of the SC units already manufactured in China are 350MW, 600MW/660MW. They are all single-reheat units. The main features of China's SC boilers and turbines are shown in Table 4-5.

**Table 4-5 Technical Features of Single-reheat SC Boilers and Turbines**

	350MW SC Unit	600/660MW SC Unit
Boiler Type	Two-pass Boiler	Two-Pass boiler
Combustion mode	Tangential firing, and W-shaped flame firing (for anthracite)	Tangential firing, Wall-type firing, and W-shaped flame firing (for anthracite)
Boiler hydrodynamic mode	Once-through boiler	Once-through boiler
Turbine type	(1) Turbine of Separated HP & IP cylinders: combination of impulse type and reaction type blades, three cylinders with two exhausts (2) Turbine of Integrated HP & IP cylinders: Impulse type blades, two cylinders with two exhausts	(1) Turbine of Separated HP & IP cylinders: impulse type blades, four cylinders with four exhausts (2) Turbine of Integrated HP & IP cylinders: impulse type blades, three cylinders with four exhausts
Steam distribution mode of turbine	(1) Turbine of Separated HP & IP cylinders: full-arc admission +	(1) Turbine of Separated HP & IP cylinders: hybrid steam distribution

	overload valve (2) Turbine of Integrated HP & IP cylinders: nozzle governing steam distribution	(2) Turbine of Integrated HP & IP cylinders: nozzle governing steam distribution
Turbine extraction number	8	8
Unit startup and operation mode	HP-IP cylinder start-up or IP cylinder start-up Hybrid operation mode	

### 4.2.3 Technical Features of USC Single-reheat Unit

The fleet of USC units manufactured in China is 660MW and 1000MW with the main steam pressure from 25MPa to 27.25MPa, the main steam temperature of 600°C, and the reheat steam pressure of 600°C as general parameters. These USC units are the major fleets in China at present.

The types of USC boilers are mainly Two-pass Boilers and Tower-type Boilers. Their characteristics are shown in Table 4-6, and the schematic diagrams are shown in Figures 4-3 and 4-4.

**Table 4-6 Characteristics of Two-pass Boilers and Tower-type Boilers**

	Two-pass Boiler	Tower-type Boiler
Heating surface arrangement	Arranged above the furnace, horizontal flue pass and rear part vertical flue pass of the boiler	Arranged above the furnace
Type of heating surface	U-shaped, partially horizontal heating surface	Full horizontal heating surfaces
Furnace characteristics	Lower in height with larger cross-section	Higher in height with smaller cross-section

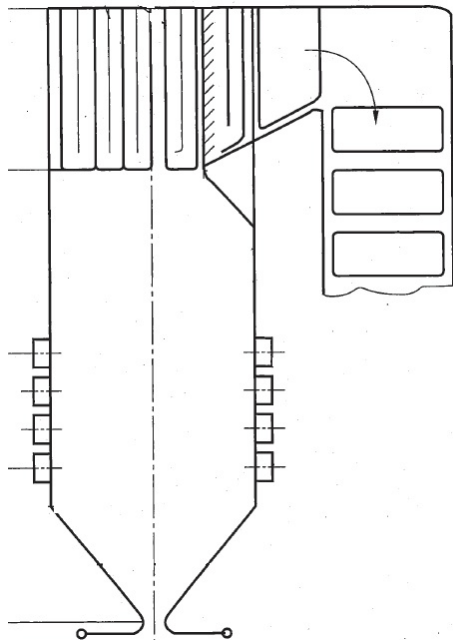

**Figure 4-3 Schematic diagram of Two-pass boiler**

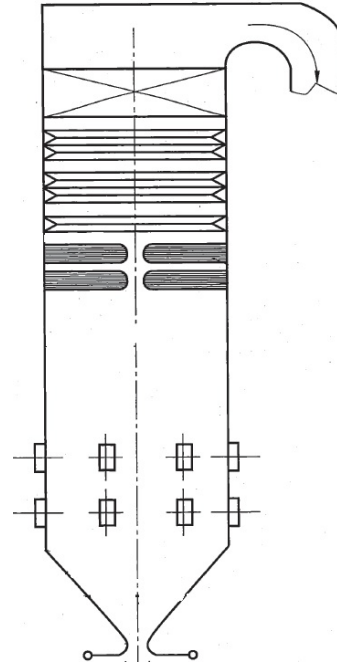

**Figure 4-4 Schematic diagram of Tower-type boiler**

The characteristics of USC steam turbines produced in China are shown in Table 4-7

**Table 4-7 Technical Features of Single-reheat SC Steam Turbine Manufactured in China**

	660MW/1000MW USC turbine
Type	Impulse type blades, four cylinders with four exhausts
Steam distribution mode of turbine	full-arc admission + overload valve
Turbine extraction number	8 or 9
Unit startup and operation mode	HP-IP cylinder start-up or IP cylinder start-up Hybrid operation mode

Since 2012, the main steam pressure of newly built single-reheat USC units in China has been raised to 28MPa and the reheat steam temperature, to 620 °C , improving the thermal efficiency theoretically. Coupled with parameters increase, quite a few design optimizations have been carried out for the whole power plant, which are shown in Table 4-8. These measures have greatly improved the overall efficiency of USC units.

Therefore, this type of unit is called efficient USC units by Chinese users.

**Table 4-8 Major Design Optimization of Efficient USC Unit**

Type of optimization	Name of technology
Thermodynamic system	Steam cooler, No. 0 HP heater, BEST heat regenerative system
Steam turbine frequency modulation Technology	Condensate water frequency modulation, high pressure heater frequency modulation, extraction steam frequency modulation
Flue gas heat recovery technology	Low-temperature economizer, flue gas energy cascade utilization technology, flue gas heat dual recovery technology.
Optimization for the cold end of steam turbine	Optimization of turbine back pressure, condenser type, circulating pump setting, and high-level water collection cooling tower
Main building layout	Compacting main building layout, boiler side coal-bunker arrangement

#### 4.2.4 Technical Features of USC Double-reheat Unit

Compared with the single-reheat boiler, the double-reheat boiler employs an additional primary reheater so that the configuration and arrangement of reheater and superheater heating surfaces are distinctively different. Take the tower boiler as an example, all heating surfaces of the single-reheat tower boiler are arranged on the upper part of the furnace from bottom to top in parallel. The heating surface of the USC double-reheat tower boiler designed in China is also placed over the furnace. However, the heating surface area is divided into the upper and lower parts. Furthermore, the upper part is divided into front and rear flue gas section, in which respectively, the low-temperature part of the first reheater and part of the economizer are arranged in the front section, and the low-temperature part of the second reheater and of the rest of the economizer are arranged in the rear section. The rest heating surfaces are arranged in the lower part.

There is no significant difference between the two kinds of turbine in terms

of materials used, structure of flow path and cylinder, etc. The major difference between a single-reheat steam turbine and a double-reheat steam turbine is that the later has one more reheating process, thus one more cylinder is needed, and its shafting length increasing. Therefore, the shaft stability and shaft expansion of double-reheat steam turbine is more complicated than that of single-reheat steam turbine.

#### 4.2.5 Technical Features of Air-cooling Power Generation

Air cooling power generation technology is a water-saving power generation technology that directly or indirectly cools the exhaust steam of turbine via ambient air. The water consumption rate of circulating water cooling power plants is  $0.6\text{m}^3/\text{s}$ - $0.8\text{m}^3/\text{s}$  per 1GW, 70% ~ 80% of water lost through cooling towers, while the water consumption rate of air-cooling power plants is less than  $0.2\text{m}^3/\text{s}$  per 1GW. This means that the water consumption rate of a wet-cooling unit is 5 to 10 times to that of air-cooling units of the same unit capacity.

Due to the large terminal temperature difference of air-cooling facilities and being easy to be influenced by atmospheric temperature changes, the air-cooling turbine features higher back pressure and larger range of back pressure fluctuation. The back pressure of direct air-cooling turbine generally varies from  $8.5\text{kPa(a)}$  to  $40\text{kPa(a)}$ , while that of indirect air-cooling units generally varies from  $6.0\text{kPa(a)}$  to  $35\text{kPa(a)}$ . Because of the

higher back pressure of the air-cooling turbine, the cycle efficiency is relatively 5% lower than that of wet-cooling turbine, so that in consequence, the annual average standard coal consumption rate of air-cooling units is 10g/kWh to 20g/kWh more than that of wet-cooling units.

The air-cooling system can be identified as three basic types, i.e. direct air-cooling system, indirect air-cooling with surface condenser and indirect air-cooling with hybrid condenser, all of which are proven technologies. In an individual project, a proper air-cooling system shall be selected according to local meteorological conditions and environmental factors.

### **4.3 China’s Achievements in the Application of SC/USC Technology**

**China has the largest USC fleets in the world.** By the end of 2017, China had 481 SC/USC coal-fired power units in operation, of which 103 are 1000MW USC units. At present, the number of USC units operating in China far exceeds the total number of rest region.

Unit efficiency has led the world. According to the statistics of China Electricity Council (CEC), the annual average operating efficiency of China’s 1000MW USC and 600MW USC wet-cooling units ranked in the first class in the world in 2017, as listed in Table 4-9.

**Table 4-9 Average Efficiency of 1000MW and 600MW Wet-Cooling Units in China in 2017**

	1000MW Class	600MW Class
Net Power Efficiency, (% LHV)	43.43	40.61
Net coal consumption rate,	283.22	302.90

g/kwh		
-------	--	--

Unit reliability has ranked among the first class in the world. In 2017, the equivalent reliability factor of large capacity units in China reached 92.2% cited from the report of CEC, as shown in Table 4-10.

**Table 4-10 Equivalent Reliability Factor of Large Capacity Units in China in 2017**

	1000MW Class	600MW Class	300MW Class
Equivalent Reliability Factor, %	92.72	92.54	93.16

Air-cooling technology is at the advanced level in the world too. Adopting air-cooling technology is an inevitable choice for the sustainable development of power in regions with rich coal and insufficient water resources in China. For example, two 1000MW air-cooling units can save 26.64 million tons of water per year, an equivalent of water consumption of 800,000 people, comparing with the water consumption of the wet-cooling units of same capacity, realizing water conservation rate of 80%.

#### **4.4 Policy Drivers**

The Chinese government is very supportive of CCT by guiding and promoting CCT through measures such as policies, standards and increasing investment in science and technology research.

First, the government invests heavily in R&D. MOST, the Ministry of Education (MOE), National Energy Administration (NEA) and the provincial and municipal governments have set up a variety of funding schemes to support the R&D of USC technology. The supporting fields of these funds include basic science study, R&D on material, equipment R&D,



engineering and operation technology R&D. Many research achievements have been successfully applied to engineering projects and won many national awards such as the State Science and Technology Progress Awards. Second, the government pays more attention to the energy consumption and efficiency increase. The Chinese government has issued a series of policies, setting the threshold for the coal consumption rate of the newly-built coal-fired power unit. As early as 2004, NEA required that "in the eastern provinces, priority should be given to the planning and construction of coal-fired power stations with the (gross) coal consumption rate of no more than 275g /kWh. *The Action Plan for the Transformation and Upgrading of Coal Power Energy Conservation and Emission Reduction (2014-2020)* published by NEA in 2014 provides that "the designed (net) coal consumption rate of newly-built 1000MW wet-cooling and air-cooling coal-fired power units shall not be higher than 282g/kWh and 299g/kWh respectively, and the figure of newly built 60MW wet-cooling and air-cooling coal-fired units shall not be higher than 285g/kWh and 302g/kWh respectively"<sup>[3]</sup>. These policies have continuously improved the efficiency of newly-built coal-fired power units.

Third, a system of standards for SC/USC power generation has been formed. Relevant power industry standardization committees have issued and revised hundreds of national standards and industry standards, covering all aspects of SC/USC power generation, including material manufacturing, equipment manufacturing, the whole infrastructure process of power plant project i.e. plan and engineering, construction,

commissioning, test, operation and maintenance, and involving many industries such as machinery, electricity, metallurgy, chemical industry, IT. For example, the national mandatory standard *The Norm of energy consumption per unit Product of General Coal-fired Power Set* (GB21258) has specified coal consumption rate for SC/USC unit. The standard was issued in 2007 and revised in 2013 and 2017. The requirements for coal consumption of units have been gradually strict, which drives technological improvement. At present, a complete system of standards and codes of the entire industrial chain of SC/USC power generation technology has been established and is still being updated.

Fourth, the government encourages the engineering application of innovative technologies by means of approving demonstration projects. In 2012, NEA issued administrative measures for major national energy science and technology demonstration projects, giving priority to scientific and technological innovation as the key to promoting the transformation of energy production and utilization modes, building a safe, stable, economic and clean modern energy system, and accelerating the R&D and industrialization of advanced technologies in the energy field.

Fifth, benchmarking and appraisal are conducted within the industry. Every year, CEC conducts a nationwide benchmarking of the energy efficiency level and reliability level of thermal power units, and issues annual reports on the efficiency and reliability of the national power system. In the report,

the Council evaluates the energy consumption level and availability level of almost every operating unit of 300MW and above in China. CEC and other industry associations regularly conduct various technical seminars. Within individual power utilities group, there are also some benchmarking and appraisal for the power plant of its own. All these activities have promoted the overall technological progress of the thermal power industry. The last but not the least, local government and residents have strict requirements on environmental protection of coal-fired power plants. According to China's *Environmental Protection Law* and *the Environmental Impact Assessment Law*, environmental impact assessment must be carried out before the coal-fired power plants construction, and the results must be publicized with the consent of the residents and the local government where the power plants are located. Local authorities have successively promulgated local standards for pollutant emissions and coal consumption limits for power plants. All these measures are huge incentives for power plant investors and operators to adopt advanced technologies and continuously improve the environmental protection and energy consumption of newly-built power plant and operating power plants.

## **4.5 Typical Cases of Project Construction and Operation**

### **4.5.1 Taizhou Power Plant**

#### **(1) A Brief Introduction**

Taizhou Power Plant is located in Taizhou City, Jiangsu Province, China. Since it was commissioned, the plant has improved the power supply

stability for the regional power grid, filled the gap not only in local electricity supply, but also in industrial steam. It has also boosted local employment. (Figure 4-5 and Figure 4-6)

Phase I engineering project employs two 1000MW USC units commissioned in December 2007 and April 2008 respectively and designed by East China Electric Power Design Institute Co., Ltd (ECEPDI). The main equipment was supplied by Harbin Electric Corporation. The project has won “Luban Prize (The Luban Prize for Construction Project)”, the highest prize on construction quality in China.

Phase II project employs two 1000MW USC double-reheat units commissioned in September 2015 and January 2016 respectively and also designed by ECEPDI. The main equipment was supplied by Shanghai Electric Group Cooperation. The Unit 3 is the first 1000MW USC double-reheat unit in the world, designed by ECEPDI. This project has won the Gold Prize of National Quality Project Award. Both prizes demonstrate that the overall quality of Phase I and Phase II projects of Taizhou Power Plant is among the top class in China.



**Figure 4-5 A Bird View of Taizhou Power Plant**



**Figure 4-6 Taizhou Phase II Double-Reheat Steam Turbine**

## (2) Technical Features

### 1) Efficient double-reheat technology

Phase II units have adopted advanced double-reheat technology, ensuring that the unit designed gross power efficiency is no less than 47.92% (LHV) and designed coal consumption rate is not over 256.28g/kWh. The operation data in nearly three years indicates that the average operation

gross power efficiency of the units is 47.82% (LHV, 257.2g/kWh in coal consumption rate), 0.95 percentage points higher than the best performance unit ever in the world. Figure 4-11 compares Phase II units with conventional USC single reheat units.

**Table 4-11 Comparison between Phase II Unit and the Normal USC Single Reheat Unit**

Item	Conventional USC Single Reheat Unit 2×1000MW	Unit of Taizhou Phase II 2×1000MW
Steam Parameters	25MPa/600°C/600°C	31MPa/600 °C /610 °C /610°C
Turbine heat rate (kJ/kWh)	7350	7040
Boiler efficient (% ,LHV)	94	94.65
Unit gross power efficient (% , LHV)	45.58	47.92
Gross coal consumption rate (g/kwh)	270	256.28
Coal consumption per year ( million ton)	2.97	2.812

A number of advanced technologies are used in designing the Phase II units, including: (1) Advanced double reheat boiler and turbine with the parameters of 31MPa/600°C/610°C/610°C, (2) Advanced thermal system configuring 4 HP Heaters, 5 LP Heaters, 1 Deaerator and 2 Steam Coolers, (3) Flue gas heat recovery system to improve the efficiency of the units furthermore. Figure 4-7 shows the effect of individual technology measure on heat rate of steam turbine.

**Figure 4-7 Effect of Individual Technology Measure on Heat Rate of Steam Turbine**

2) Ultra-low pollutant emissions

The art-of-the-state ultra-low emission technologies, such as SCR denitration, electrostatic and wet dust precipitator, and limestone-gypsum wet flue-gas desulfurization, are applied in the power plant to ensure that the flue gas pollutants emission is lower than national rule limit for ultra-low emission, as shown in Figure 4-8.

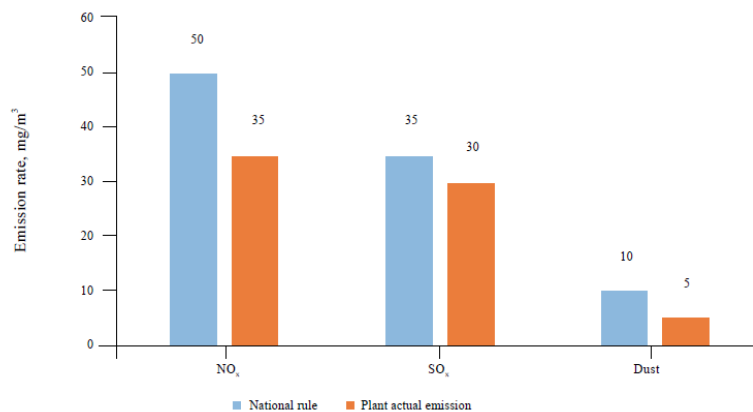

**Figure 4-8 Plant actual emission rate vs. national rule**

(3) Management Features

Standardized management processes including drawings management and protocol formulation, etc. which comply strictly with the National Code are set up to standardize the work flow.

Benchmarking management is adopted by carrying out through standardized operation, synergistic operation, differentiated management and all-factor control. Indicators such as coal consumption rate, house power rate, main steam temperature, reheat steam temperature, and flue gas temperature are benchmarked not only to that of the advanced units of the same type in China, but also to design values and historically best values itself. Lists of indicators with positive and negative variance are drawn. Positive variance analysis was conducted to summarize into the good technical means, which will be consolidated. Negative variance analysis is carried out to find out reasons, and rectification plans are mapped out for implementation. Competitions are held to encourage performance improvement, so that employees are effectively mobilized to adjust operation indicators to promote energy saving and cost cut.

#### (4) Operation Results

Operation performance from 2016 to 2018 indicates that the gross coal consumption rate of two units of Phase II were 256.91g/kWh and 256.15g/kWh respectively, 6.6g/kWh lower than the best the world record and 6g/kWh lower than the best Chinese record. The unit gross



power efficiencies were 47.82% and 47.95% (LHV) respectively, 0.95 percentage points higher than the best in the world. Up to the mid-December of 2018, total power generation of two units of Phase II stood at 38300GWh. Advanced technologies adopted in the Taizhou power plant have brought sound return on investment.

## 4.5.2 Ninghai Power Plant

### (1) A Brief Introduction

Ninghai Power Plant (Figure 4-9) is located in NingBo City, Zhejiang Province, China. It is an important electrical power source supporting east China power grid, and it plays a crucial role in economic development and improvement of the people's life and well-being in Zhejiang Province.

Phase I project involves four 630MW subcritical coal-fired power units with the parameters of 17.5MPa/538 °C /538 °C . Phase I project was commissioned in 20 November 2006 and won the Gold Prize of National Quality Project Award.

Phase II project involves two 1000MW USC coal-fired power units with the parameters of 26.25MPa/600 °C /600 °C . Phase II project was commissioned in 2009 and won the Luban Prize for Construction Project. Phase I and Phase II projects were designed by Southwest Electric Power Design Institute Co., Ltd (SWEPTDI). The main equipment was supplied by Shanghai Electric. The project has won the “Luban Prize”



**Figure 4-9 A Bird View of Ninghai Power Plant**

## (2) Technical Features

Ninghai Power Plant was constructed in line with the most advanced standard at that time. Phase I project adopted three new technologies in China for the first time, i.e. an integrated control room for four units, four boilers sharing one chimney with four-steel-tube inside, the first 600MW subcritical unit with its denitrification facilities designed, installed and commissioned simultaneously in the construction period.

Phase II project adopted three new technologies for the first time, i.e. the largest seawater cooling tower in Asia with the height of 177.2 meters and drenching area of 13,000 m<sup>2</sup>, plasma ignition technology used in tower boiler of 1000MW units, field bus control system (FCS) used in the desulfurization system of 1000MW units.

## (3) Management Features

The energy efficiency indicators of the units in Ninghai Power Plant did

not outperform other plants only after a few years of commissioning, due to a number of newer power plants adopting more advanced technologies commissioned in recent years. The gap between the most advanced units in other power plant and units in Ninhai Power Plant is widening over time. In order to enhance enterprises competitiveness, Ninghai Power Plant has successively carried out comprehensive upgrading and retrofit including turbine capacity enlargement and flow path modification, flue gas pollutant emission control system during 2015-2017. Its energy efficiency indicator has been greatly improved, and its pollutant emission in flue gas has been greatly reduced. The unit efficiency and operation performance of power plants reached the advanced level in China once again.

The coal consumption rate has been greatly reduced via comprehensive upgrading and retrofit. In 2016, Steam turbine of Phase I units is retrofitted on the flow pass with advanced thermodynamic design and structural design adapted by the manufacturing works, and the corresponding auxiliary facilities modification were carried out at the same time. Thus, expected goal has been met successfully. The efficiency of HP, IP and LP cylinder of the steam turbines under various working parameters has been greatly improved, with an average turbine heat rate of 7776 kJ/kWh, which is comprehensively better than the design value.

The excellent emission indicators of phase I units is achieved by ultra-low

emission retrofit in 2016, via comprehensive measurements of low NO<sub>x</sub> burner (LNB), low-reheat-steam-temperature treatment, low-temperature economizer, high efficient dry-type electrostatic precipitation (ESP), combination of induced draft fan and flue gas desulfurization (FGD) blower fan, high efficient FGD scrubber, wet-type ESP, chimney “rain” treatment. The ultra-low emission treatment measurements used for phase II units features on LNB, low-reheat-steam-temperature treatment, optimization of induced draft fan and blower fan, high efficient dry-type ESP, improvement of desulfurization efficiency, diversion trench installed in chimney.

#### (4) Operation Results

After the retrofit, the average annual net coal consumption rate of phase I units is 304.24g/kWh (the best record) /307.34g/kWh (average value), which is 12~14g/kWh lower than before. In the National Unit Performance Competition 2017, two units were listed among the top 20% on the index of coal consumption rate and house power rate.

After the retrofit, the emission of dust concentrations, SO<sub>2</sub> and NO<sub>x</sub> inside the flue gas of phase I unit are 1 mg/Nm<sup>3</sup>, 15 mg/Nm<sup>3</sup> and 30 mg/Nm<sup>3</sup> respectively, and the figures of phase II unit are 2.2 mg/Nm<sup>3</sup>, 13 mg/Nm<sup>3</sup> and 28 mg/Nm<sup>3</sup> respectively, which are all lower than the limitation figures of 5 mg/Nm<sup>3</sup>, 35 mg/Nm<sup>3</sup> and 50 mg/Nm<sup>3</sup> according to the state ultra-low

emission standards.

### 4.5.3 2×1050MW Coal-fired Power Generation Project, Java No.7, Indonesia

#### (1) A brief introduction

The Java No.7 power plant is located in Banten provinces, Indonesia, 100km south-eastern to Jakarta, 13km north-western to Merak as demonstrated in Figure 4-11<sup>[4]</sup>. The power plant is planned six units of 1000MW. It is the first 1000MW class unit exported overseas from China. If this project is completed, it would effectively relieve the power shortage in Java.

The phase I project employs two 1050MW coal-fired USC units with parameters of 27MPa/600°C/600°C. The project was commenced on June 30, 2017, and is scheduled to be commissioned by the end of 2019. The project was designed by Shandong Electric Power Design Institute. The boiler is provided by Babcock & Wilcox Beijing Company Ltd (B&WBC). The steam turbine and generator are provided by Shanghai Electric Corp.



**Figure 4-10 Location of Java 7# Project**

## (2) Technical Features

The project is equipped with the largest lignite-fired boiler, the largest the three-phase integrated transformer, the largest pulverizer, the flue gas seawater desulfurization facility, and the seawater desalination device, the intellectual property rights of which is owned by Guohua Power Corp.. Once completed, the power plant will involve the units with the largest capacity and highest parameters in Indonesia, as well as the most advanced and environmental-friendly units in Indonesia. It will be the one with the highest degree of automation in Indonesia functioned with APS (automatic power plant startup and shutdown) and FCB (fast cut-back).



**Figure 4-11 A Bird View of Java 7#**

### (3) Design Objective

After project completion, the heat rate of the turbines will be no higher than 7333 kJ/kWh, the boiler efficiency will be over 92.6% (LHV), the house rate of the plant will be less than 5%, and the net coal consumption rate will be 287.6g/kWh.

### (4) Management Features

The project is constructed in an EPC mode, contracted by the EPC consortium comprising Zhejiang Thermal Power Construction Co., Ltd and Shang Dong Electric Design Institute.

The general principle for the project management of Java No. 7 project is, on one hand, following the traditional ways used in power plant construction in China, and on the other hand, complying with the rules of infrastructure control system of China Energy Cooperation focusing on

safety, quality, progress, and investment etc. lead by engineering. The three partners of the project, i.e. the project company, the EPC consortium and the supervision company, follow the guidance of *the Opinions on the Principles of GHepc General Contracting Model* and the infrastructure control system of Guohua Power Cooperation. On the principles of “managing personnel by the system and businesses by the procedures”, the infrastructure control system covers 181 regulations and procedures in 14 segments, thus effectively guaranteeing the quality of the project.

## References

---

[1] China Electricity Council. Clean Development of Coal-fired Power in China [M]. Beijing: China Electric Power Press, 2017.

[2] National Development and Reform Commission, Ministry of Environmental Protection, National Energy Administration. Coal-fired energy-saving emission reduction upgrade and transformation action plan (2014-2020) [Z]. September 12, 2014.

[3] Wang Zhixuan. Renovation and New Historical Mission of Coal Power during the four decades [J]. *Observation on New Energy Economy and Trade*, 2018(09): 18-22.

[4] The design and construction documents provided by Guohua Power Branch of China Shenhua Energy Co., Ltd.



## **Chapter V Power Generation Technology of Circulating Fluidized Bed in China**

Circulating fluidized bed (CFB) combustion technology is one of the most commercialized clean coal power generation technologies well acknowledged in the world, due to its outstanding fuel flexibility, wide load adjustment range and convenient ash and slag handling. Especially, CFB combustion has outstanding merits in large-scale efficient utilization of inferior coals.

There are many kinds of coals in China. Most of them are inferior coals with low calorific value or high sulfur content have the major proportion. CFB boilers can burn these coals that are difficult to be burnt in conventional pulverized coal boilers, even special fuels like coal gangue, oil coke and municipal wastes. Thus, utilization of CFB boilers is promising in China.

### **5.1 Development of CFB power generation technology for the utilization of numerous inferior coals**

China has rich coals but insufficient oil, uranium fuel and natural gas, thus coal is the most important foundation energy that guarantees the energy security of China.

China has maintained an annual raw coal output of 3.5-3.9 billion tons since 2010 and peaked at 3.974 billion tons in 2013, as shown in Figure 5-1. Among the annual output, about 20% is inferior coals with calorific values less than 3500kcal/kg(LHV), about 0.7 billion tons. If these inferior

coals cannot be consumed timely, plenty of solid waste will be produced, which results in not only severe environmental contamination but also large land occupation.

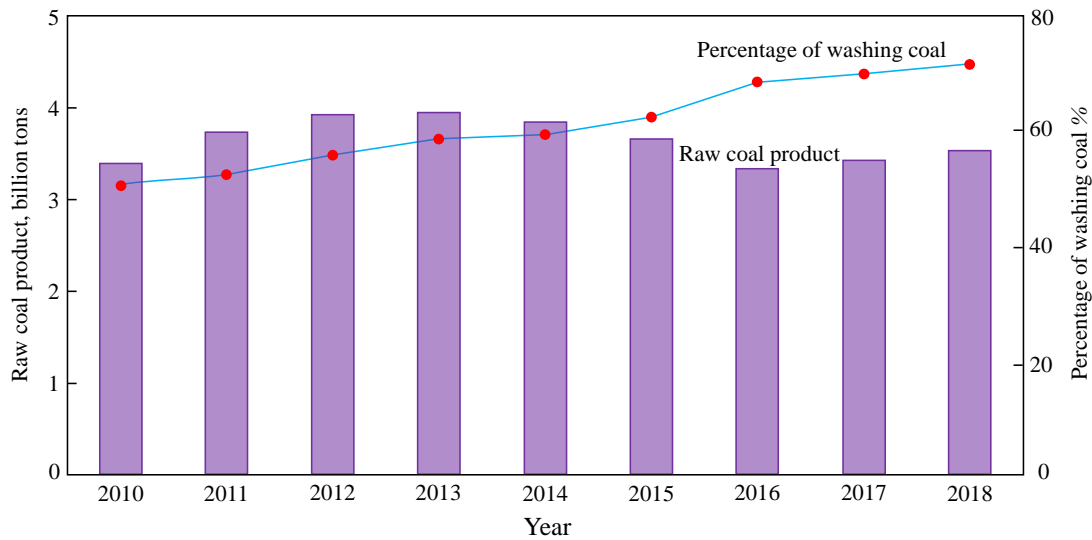

**Fig.5-1 Raw Coal Production and the Percentage of Washing Coal During 2010-2018**

With the acceleration of China’s ecological conservation and the technical progress of coal washing, the selected ratio of raw coals is increasing continually. The selected ratio of raw coals in China was just over 50% in 2010, while in 2018, it increased to 71.8%. Except for producing cleaned coals, coal washing would also produce plenty products of low calorific value including middling, coal slime and coal gangue. Since 2010, about 0.5 billion tons of coal slime and coal gangue have been produced annually in China, and most of them had a calorific value higher than 1200kcal/kg(LHV).

How to utilize these low calorific value byproducts of coal washing, improve energy efficiency and protect the ecological environment of mining area are big issues of China’s coal industry. CFB power generation

technology has unique advantages in comprehensive utilization of low calorific value fuels over other power generation technologies.

## **5.2 The development history of CFB boiler in China**

Since 1960s, China has begun to explore the bubbling bed combustion technology, and a series of bubbling bed boilers were developed. As of the beginning of the 1980s, China had about 3000 bubbling bed boiler units for heat and power generation, becoming the economy with the largest capacity of such boilers in the world.

Since the 1980s, the CFB combustion technology was put forward and studied in China as well as other economies. Due to the lack of systematic theoretical research, many operation problems occurred in CFB boilers in China<sup>[1]</sup>. Over more than 40 years' research and development, an independent CFB combustion technology and CFB boilers design system were established in China, which adapted to the various kinds of coals in China. The CFB boilers designed in China had higher operation reliability and covered all kinds of boiler parameters (subcritical, SC, etc.), capacities (from 65t/h to 660MWe) and fuels (bitumite, lignite, gangue, etc.)<sup>[2]</sup>.

## **5.3 Main technologies of the CFB boiler power generation in China**

### **5.3.1 Subcritical and below CFB power generation technology**

Since 1980s, a series of CFB boilers, whose capacities covers 35t/h to 130t/h, were designed in China for steam generation and heating supply,

and are mainly applied in thermal power plant and industrial captive power plant. With many years' research and operation experiments, the researchers and engineers in China have mastered the comprehensive CFB combustion technology and boiler design method. The structure of CFB boilers has been optimized and the boilers' operation performance is increasingly better, which proved good economy and industrialization has been achieved.

In the late 1990s, due to the stricter environmental regulations, a large number of CFB boilers faced technical reform and shut-down. The demand of 135~200MW CFB boilers brought the opportunity to the development of CFB boilers in China. Dongfang Boiler Company Ltd., Harbin Boiler Company Ltd. and Shanghai Boiler Company Ltd. (three giant boiler companies in China) all introduced CFB boiler design technologies from abroad. However, these technologies from abroad were not suitable for the fuels in China and requirement of varying load operation. Thus, the boiler companies in China had to design their own CFB boilers to meet the Chinese demand. Through independent research and design, many boiler companies in China had successfully designed the domestic CFB boilers, which showed better operation performance and exported to abroad.

300MW subcritical CFB boilers also experienced similar development process like 135~200MW CFB boilers introduced above. Three main boiler companies in China brought in 200~350MW subcritical CFB boiler technology from Alstom, and constructed a demonstration project in Baima Power Plant, Sichuan, China, validating the technical feasibility and

economy of 300MW CFB boilers in power generation. After that, 20 units of 300MW CFB boilers with Alstom technology were constructed and commissioned. However, with long time operation, the CFB boilers designed abroad were not suitable for complex fuel characteristics in China. Thus, the researchers and engineers in China had to study and design the 300MW CFB boilers. During the 300MW CFB boilers design, the engineers in China studied the experiences and lessons from abroad. They simplified the boiler structure and optimized the boiler parameters. Compared with imported technologies, the 300MW CFB boilers designed in China had advantages in boiler operation, control and construction cost. Many power plants in China ordered such boilers with domestic design, and the total orders exceeded 100 units in a short time. The 300MW CFB boilers designed in China were also exported to abroad, such as Bosnia-Herzegovina, Malaysia, and Columbia <sup>[3]</sup>.

Up to now, a series of CFB boiler design technologies with subcritical parameters have been established in China, covering the capacity from 6MW to 350MW, the pressure from 2.4MPa to 17.3MPa and the steam temperature from 400°C to 560°C. The fuels used in CFB boilers, whose calorific value ranges from 2000kcal/kg to 6000kcal/kg (LHV), can be not only solid fuels, like anthracite, lean coal, bituminite, lignite, gangue, coal slurry, middling in coal washing, petroleum coke and biomass, but also waste with low calorific value, like municipal waste, sludge, industrial waste, etc.

### 5.3.2 SC CFB power generation technology

The impending requirements of the Chinese government on the efficiency of coal-fired generating units have promoted the improvement of unit parameters and stimulated the development of SC CFB boilers. Since 2000, with the support of the MOST, China began to conduct R&D of SC CFB boilers synchronously with the rest of the world. After more than ten years of research, the huge theoretical and engineering challenges in the technical leap over 300MW subcritical natural circulation to 600MW SC forced circulation have been solved systematically, and a complete technical system including boiler, auxiliary equipment, auxiliary system, installation, debugging, dynamic simulation and control strategy has been developed for demonstration project construction. The world's first 600MW SC CFB boiler was officially transferred to commercial production after operating at full load for 168 hours in Baima, Sichuan on 14 April 2013<sup>[4]</sup>. The performance has fully met the expectation. IEA has regarded Baima project as a landmark event in the development of international CFB technology [5] (as shown in Figure 5-2), marking that the CFB technology in the China has reached the world leading level<sup>[6]</sup>.

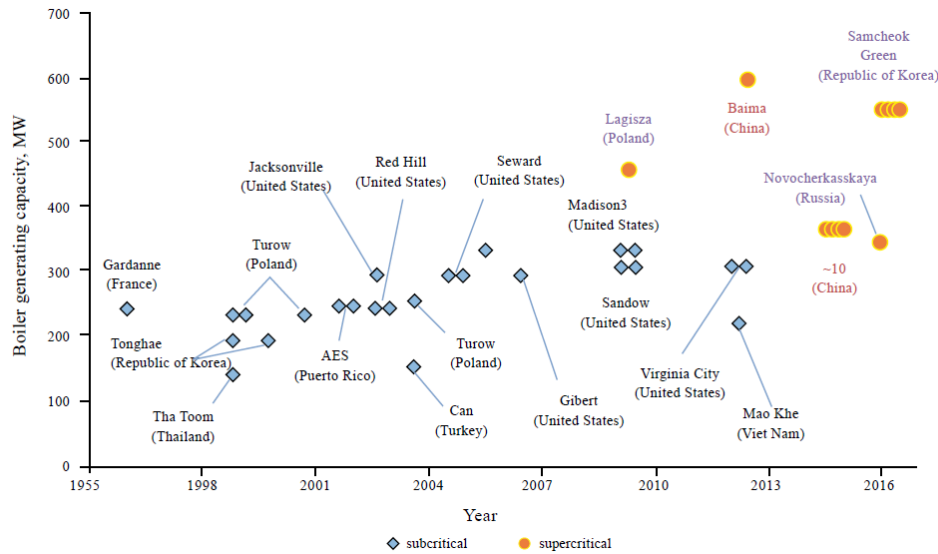

**Fig.5-2 Developing milestone of CFB boiler technology**

The 350MW SC CFB boilers have been developed with excellent performance based on the research achievements of 600MW SC CFB boiler [7].

### 5.3.3 Ultra-low emission CFB combustion technology based on fluidization state optimization

The huge market in China provides practical conditions for the continuous innovation of CFB technology. The auxiliary power consumption rate of conventional CFB boiler is 2% to 3% higher than that of the pulverized coal boiler with the same capacity for the need of high-pressure head fan to maintain material fluidization and circulation, and the fluidization of coarse particles at the bottom of the furnace is easy to cause wear. In order to solve the above problems, Chinese researchers proposed the concept of fluidization state specification and the idea of changing the fluidization state of the designed region [8]. The performance of the material circulation system could be improved by engineering measures such as increasing the efficiency of the cyclone, reducing the resistance of the return material, and

strengthening the mixing intensity of the secondary air<sup>[9]</sup>, thereby changing the particle concentration distribution along the height of the furnace to ensure the particles concentration in the upper part of the furnace the same with or slightly over the conventional level while the height of the dense phase zone in the lower part decrease significantly. The first energy-saving CFB boiler (15MW) based on the fluidization state specification was commissioned in 2007, saving 5 million kWh of electricity per year<sup>[10]</sup>. The energy-saving CFB boiler with a capacity of 75-1000t/h has been rapidly popularized in small and medium-sized capacity CFB boiler market in China and has entered the foreign market due to its advantages of low auxiliary power consumption and high reliability.

Chinese researchers have also proposed a new idea of flow pattern optimization on the above basis. The original NO<sub>x</sub> emissions can be further reduced by effectively reducing the particle size of bed materials. When typical kinds of coals are applied, the original NO<sub>x</sub> emission can be reduced to lower than 50mg/m<sup>3</sup>. The high-efficiency desulfurization technology using limestone particles finer than the existing common ones can realize SO<sub>2</sub> emission lower than 35mg/m<sup>3</sup> with ratio of calcium to sulfur (Ca/S) being 1.9, which provides a new development direction for the ultra-low emission of CFB boiler<sup>[11]</sup>. This technology is gradually becoming a mainstream in CFB boiler market with a capacity under 200MW in China.

## **5.4 Policy Drivers for CFB power generation industry**

### **5.4.1 Policy Drivers for CFB power generation industry**

Since 1998, China's government agencies such as NDRC, the former State



Economy and Trade Commission have issued the "*Coal Gangue Comprehensive Utilization Management Measures*", "*Key Points of Coal Gangue Comprehensive Utilization Technology Policy*" and other documents. These documents emphasized that in the process of coal gangue comprehensive utilization, the key point was bulk quantity, and one of the main directions was coal gangue power generation.

Technical requirements for coal gangue power generation are listed as follows. (1) The coal gangue with high carbon content (calorific value greater than 4.18MJ/kg, LHV) after washing can be burned as low calorific value coal in CFB boiler. (2) The coal gangue with calorific value greater than 6.27MJ/kg(LHV) can be used directly as the fuel of CFB boiler without washing. The calorific value of coal gangue for power generation should be below 12.55MJ/kg(LHV). The heat produced by the CFB boiler can be used for not only generating electricity but also supplying heat. (3) The production of sulfur oxides and nitrogen oxides in flue gas can be reduced by adding desulfurizer such as limestone or dolomite to the furnace of CFB boiler. The ash slag after burning is a good raw building material. Technical requirements for coal gangue and coal slime co-combustion power generation are listed as follows. The calorific values of coal gangue and coal slime should be 4.5-12.55MJ/kg(LHV) and 8.36-16.72MJ/kg(LHV) respectively; coal slime moisture content should be 25-70%. The co-combustion using fluidized bed and CFB boilers adopts coal gangue and coal slurry, coal gangue and slime cake.

*"Energy Saving Power Generation Dispatching Method (Trial)"* specified

that the unit power generation priority is determined by the following order: (1) Renewable energy generator units adopting wind power, solar power or hydro power; (2) Renewable energy generator units adopting hydro energy, biomass energy or geothermal energy and waste generator sets meeting environmental requirements; (3) Nuclear power units; (4) Heat-load-based coal-fired cogeneration units and generator units comprehensively utilizing residual heat, residual gas, residual pressure, coal gangue, middling in coal washing, coalbed methane and other resources; (5) Natural gas, coal gasification generator units; (6) Other coal-fired generator units; (7) Oil fuel generator units.

Moreover, China has formulated a series of policies to support the comprehensive utilization of coal gangue power generation. For example, the comprehensive utilization power plants with capacity less than 12MW are banned from peak regulation. The comprehensive utilization power plants with capacity greater than 12MW can obtain a certain peak regulation capacity, even full load during peak hours, while, the load must be more than 85% load during off-peak hours.

5.4.2 Fiscal and tax policy drivers for CFB power generation  
*“The Catalogue of Comprehensive Utilization of Resources”* specifies that the comprehensive utilization of solid waste includes the utilization of coal gangue, stone coal, coal slime, oil shale, low calorific value fuel and coalbed methane for the electricity and heat generation. *“Notice on Further Comprehensive Utilization of Resources”* clearly states that measures should be taken to support the comprehensive utilization power plants to

produce electricity and heat.

Policies provide fiscal and tax preferential support for the comprehensive utilization of coal gangue. For example, certified coal gangue comprehensive utilization power plants enjoy the policy of 50 per cent discount on the import duty and value added tax; the enterprises that produce electricity and heat with low-calorific fuels such as municipal waste, coal gangue and coal slime should be allowed to connect to the power grid, exempt from generation infrastructure costs, and give priority to power generation scheduling once meet the requirements of grid-connection scheduling. In principle, the feed-in tariff is based on the principle of the same quality and price in the same net. The price can be set individually if the generation cost is extremely high, and the expense incurred by the power grid can be included in the cost.

The national demonstration project has promoted the rapid development of CFB power generation technology. In 2006, the first domestically produced CFB demonstration power station project, 300MW CFB boiler in Baima, Sichuan which belongs to China Energy, was successfully commissioned with the support of the relevant state departments. In 2013, the independently developed 600 MW SC CFB demonstration power station project in Baima, Sichuan which belongs to China Energy was successfully put into operation. In 2019, the 660 MW CFB demonstration power station project with the ultra-SC, ultra-low emission and ultra-low energy consumption in Binchang, Shanxi which also belongs to China Energy was listed as a national power demonstration project. Such national

demonstration projects have given a strong impetus to the rapid development of CFB technology in China.

## **5.5 Application achievements of CFB power generation technology in China**

### **5.5.1 A complete set of CFB design, manufacturing and construction technology**

After several decades of development, many boiler group companies in China have been able to design and manufacture CFB boilers with various parameters and capacities, which also have independent intellectual property rights and are suitable for various fuels and construction conditions. Besides, the corresponding auxiliaries provided by auxiliary equipment companies and the high-level installation carried out by engineering companies have altogether formed a complete set of construction technologies. China now has the world-leading design, manufacturing, construction and operation technologies of various CFB boilers.

### **5.5.2 Great amount of inferior coal utilized with CFB power generation technology**

China is the world's largest producer of CFB boilers and the largest supplier of electricity generated by CFB boilers. So far, there are about 3,500 CFB boilers in operation, with a total capacity of more than 100GW, and the capacity distribution is shown in Figure 5-3. These CFB units utilize about 380 million tons of low-calorie fuels and generate about 403.9 billion kWh

of electricity per year.

The majority of coal-fired CFB boilers in China are small and medium-sized CFB boilers with capacity smaller than 100MW. There are more than 200 coal-fired hot-water CFB boilers used for district heating as well as more than 200 CFB boilers burning biomass and waste respectively. In recent years, due to the preferential policies on biomass power generation, biomass CFB boilers have developed rapidly in China. China's biomass resources are mainly agricultural waste. Limited by conditions and quantity, the capacity of biomass CFB boilers is usually small. In order to pursue high power generation efficiency and relatively high parameters, 25MW CFB boilers generally adopt the design of ultra-high pressure with single reheat.

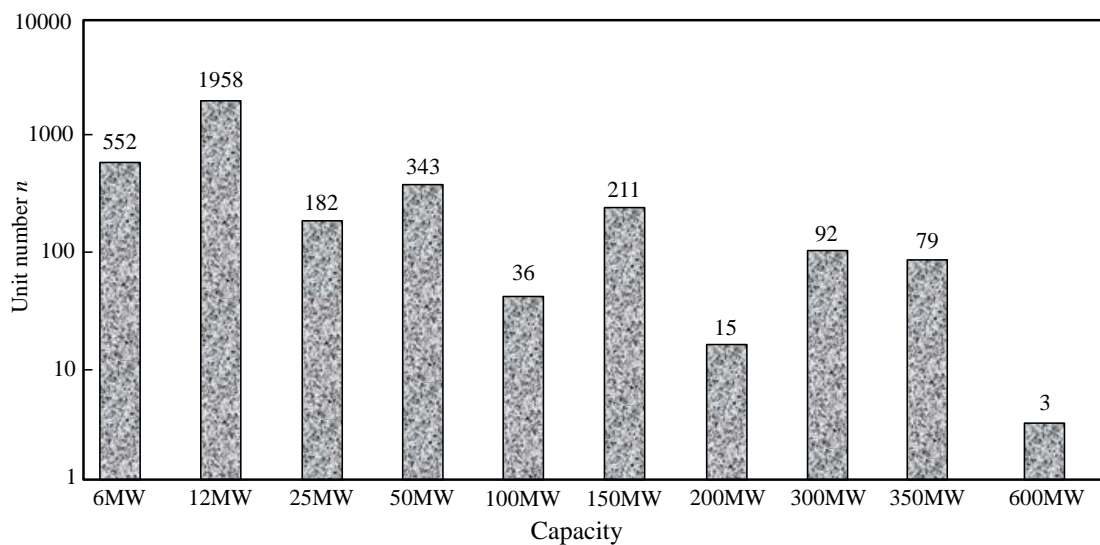

**Figure 5-3 Coal fired CFB power plants in China**

### 5.5.3 CFB boiler technology based on fluidization state specification in commercialization

To maintain the external circulation, when increasing the fraction of effective bed material content, not only the fast fluidization state in the

upper part of the furnace can be maintained, but also the inventory of coarse particles at the bottom can be significantly reduced, so that CFB boilers can operate with a low bed pressure drop. Based on such fluidization state specification, China has developed a low energy consumption CFB boiler technology, which effectively solves the common problems of high consumption of auxiliaries, low availability and combustion efficiency problems existing in the conventional CFB boilers, leading to the power consumption reduction by about 1%, and the wear of the heating surface is effectively reduced, besides the availability is generally higher than 97%. Compared with traditional CFB boilers, the performance of the boilers adopting this technology has been significantly improved. Currently, this type of boilers has become the mainstream in Chinese small and medium-capacity CFB boiler market, with the total number of more than 500 units.

#### 5.5.4 Rapid development in SC CFB power generation technology

The 600MW SC CFB boiler in Baima Power Plant was commissioned in April 2013. After six years of operation (burning high-sulfur inferior coal), it remains stable and reliable in operation and superior in performance, achieving a good demonstration effect. Pingmei Group has built two 660MW SC CFB units with the same steam parameters as the Baima project, which are mainly used for the consumption of low calorific value fuels originated from the coal mining and washing by-products in Pingshuo coal base.

By expanding the 600MW SC CFB boiler technology, China has successfully developed the 350MW SC CFB boiler, which currently has more than 80 orders (3 are exported). By the end of 2018, 27 units of 350MW SC CFB boilers had already been commissioned.

#### 5.5.5 Ultra-low emission CFB combustion technology leads CFB international development

The NO<sub>x</sub> emission of CFB boilers is generally below 200mg/m<sup>3</sup>, and 90%-95% of the sulfur dioxide can be removed by desulfurization in the furnace, which can meet the emission standards of most economies.

China's national standard "*Emission Standard of Air Pollutants for Thermal Power Plants*" (GB13223-2011) requires that NO<sub>x</sub> and SO<sub>2</sub> emission concentrations should be controlled both below 100mg/m<sup>3</sup>, resulting in a great challenge to CFB combustion<sup>[12]</sup>. In 2014, Chinese authorities required the emission concentration of NO<sub>x</sub> and SO<sub>2</sub> respectively below 50mg/m<sup>3</sup> and 35mg/m<sup>3</sup> for coal-fired power units, which places greater demands on CFB power generation technology. In some cases, expensive flue gas purification equipment has to be installed at the tails of some CFB boilers to deal with this challenge <sup>[2]</sup>.

According to the CFB boiler design theory, Chinese researchers proposed to adjust the position of particle size axis in the diagram of the fluidization state specification guides. Through the reduction of the bed material particle size, the reducing atmosphere is strengthened, and the original ultra-low NO<sub>x</sub> emission can be realized. Furthermore, the contradiction between the reaction surface area and residence time of limestone can be

solved at the same time, thus efficient desulfurization in the furnace can be realized as well. This new-generation ultra-low emission CFB combustion technology goes far beyond the knowledge of the ability of emission control of CFB combustion technology in the rest of the world. Currently, this technology has been rapidly promoted due to its outstanding performance advantages. It has become the mainstream technology of CFB boilers below 200MW in China. At present, more than 200 CFB boilers adopting this technology have been built, which represents the developing orientation of CFB boilers.

## **5.6 The significance of developing CFB power generation technology**

In China, the raw coal production and coal washing are large in amount, and a great number of low caloric value fuels, such as inferior coal, washery rejects, middling in coal washing and coal slime, are produced every year. Domestic and foreign practices show that CFB power generation technology is the best choice to achieve large-scale use of coal gangue, coal slime, middling in coal washing and inferior coal efficiently and cleanly and is able to realize the comprehensive utilization of resources. The large-scale application of CFB in China helps to realize green mining and utilization of coal.

USC CFB boiler combines the advantages of CFB low-cost pollution control and -USC high-efficiency steam cycle, and can achieve high power efficiency and low pollutant emission levels. The designed coal consumption for power supply of the constructing 660MW USC CFB



boiler is 18g/kWh and 48g/kWh lower than that of 600MW SC and sub-critical CFB boiler, respectively. Thus, developing the ultra-SC boilers is of great significance.

Due to the excellent fuel flexibility of CFB combustion, the effect of fuel mixture on operation performance is almost negligible, which is convenient for the co-firing of biomass and municipal sludge. Almost without any modification of the boiler structure, the CFB boiler can meet the requirements of co-firing. As for biomass-coal coupling power generation, CFB power generation technology is a more economical way. Therefore, vigorously developing CFB power generation technology is of great significance for the economies with more utilization of coal to improve the energy efficiency of inferior fuel.

## **5.7 Typical cases of China CFB power generation technology**

### **5.7.1 The 600MW SC CFB demonstration –Sichuan Baima power plant of China Energy**

The demonstration project of 600MW SC CFB boiler was built in Baima power plant subordinating to China Energy (shown in Fig 5-4, 5-5). The Baima demonstration project began to be constructed in 2010 and passed 168-hour-operation on 14 April 2013. The designed coal is low caloric value lean coal with ash content of 43.82% and sulphur content of 3.3%. The operating fuel is generally close to design fuel.

Baima 600MW SC CFB boiler has designed superheated steam pressure of 25.39MPa, superheated steam temperature of 571°C, main steam flow of 1819.1t/h, reheated steam temperature of 569°C, bed temperature of 890°C,

exhausted gas temperature of 128°C, desulfurization efficiency of 96.7%, and NO<sub>x</sub> emission less than 160 mg/m<sup>3</sup>. The six-year operation of the Baima 600MW SC CFB boiler shows that all the parameters of steam and flue gas completely match the designed values, indicating the accuracy of the heated surface design.



**Fig 5-4 Baima 600MW CFB boiler**

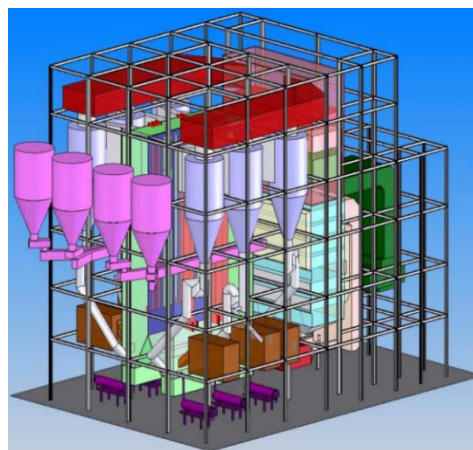

**Fig 5-5 600MW SC CFB boiler**

Compared with the SC CFB boilers developed by other economies in the same period, the Baima project shows better boiler capacity, emissions control, boiler efficiency and higher steam parameters. In spite of poorer coal quality, Baima project has 0.5% higher thermal efficiency than design parameters. With the same SO<sub>2</sub> emission, the desulfurized limestone equivalent consumption is only 80% of that in other economies; and the original NO<sub>x</sub> emissions are only 40% of that in other economies.

Due to the unique environmental characteristics of CFB, Baima 600MW SC CFB boiler can meet the requirements of emission standards at that time without additional de-NO<sub>x</sub> devices, which saves de-NO<sub>x</sub> investment. In-situ desulfurization can be achieved by just putting limestone into the furnace, saving investment cost compared with wet desulfurization. The

above two measures can decrease construction investment by 3%. Moreover, the operating cost of de-NO<sub>x</sub> and desulfurization decreased markedly, and averaged cost of per degree of electricity was decreased by ¥0.012.

Calculated by saving coal consumption 30g/kWh, a single 600MW SC CFB boiler can save 90,000 tons standard coal per year (5000 hours per year) compared with the sub-critical boiler, which shows significant economic benefits and drives local employment.

### 5.7.2 350MW SC CFB Power Generation-Xuzhou Mining of Hua Mei Thermo-Electric Power

Xuzhou Mining Co. Ltd. is a giant coal production company in East China. In order to consume the by-products, a large amount of low calorific value coals, Hua Mei Thermal Power Plant constructed 2×350MW SC CFB generating units (Figure 5-6). Units 1 # and 2 # passed 168 hours in operation in January and February 2016 respectively.。



**Fig. 5-6 Xuzhou Mining of Hua Mei Thermo-Electric Power**

The superheated steam pressure of 350MW SC circulating fluidized bed boiler is 25.4MPa. The superheated steam temperature is 571°C. The flow rate of main steam is 1110t/h. The temperature of reheated steam is 569°C. The CFB boiler is further optimized from the first generation of 350MW SC CFB boilers. A series of measures have been taken to improve combustion efficiency, reduce CO emission and carbon content of fly ash, enhance the reaction between limestone and SO<sub>2</sub>, improve desulfurization efficiency and obtain higher denitrification efficiency,.

The operation shows that under the condition of burning bituminous coal and without using SNCR, the average original emission of NO<sub>x</sub> is less than 50mg/m<sup>3</sup>, which can meet the national ultra-low emission standard and achieve low-cost emission control.

### 5.7.3 50MW Energy-saving CFB boiler-Shanxi Huoshi Captive Power Co. Ltd.

There are two 220t/h energy-saving CFB boilers built in Shanxi Huoshi Captive Power Co. Ltd. (shown in Figure 5-7). The project is a captive thermal power plant in Changzhi Chemical Industry Park, which generates electricity by inferior fuels produced from the raw coal washing. It provides electricity and heat for chemical industry park at the end of power grid, and provides cheap heat source for local residents in winter, effectively alleviating the tension of steam supply in the industrial park, and promoting local economic development.



**Figure 5-7 Huoshi Captive Power Co. Ltd.**

The fuel is bituminous coal with calorific value of 3800-4200kcal/kg(LHV) and sulfur content of 0.7%-1.2%. The boiler was commissioned in 2015. The pressure of primary air chamber is 5.5-6kPa, the furnace differential pressure in upper furnace is maintained at 1200-1400Pa, and the furnace temperature is about 830-850°C. The operating parameters fully meet the design values.

The comprehensive test of performance and environmental protection of China Special Equipment Inspection and Research Institute shows that under the condition of 90.52% boiler efficiency, by burning bituminous coal with 1.06% sulfur content, using limestone desulfurization and low nitrogen combustion in the furnace,  $\text{NO}_x$  emission can be less than  $50\text{mg}/\text{m}^3$ , and  $\text{SO}_2$  emission can be less than  $20\text{mg}/\text{m}^3$ . The project is equipped with SNCR and semi-dry desulfurization at the back of the furnace as a standby to ensure that ultra-low emission can be achieved by burning any fuels.

#### 5.7.4 100MW CFB power generation with pure combustion biomass- Biomass Electricity Co., Ltd in Thailand.

With the support of the World Bank, Biomass Electricity Co. Ltd in Thailand built a 100MW biomass power generation project using local forestry and agricultural wastes (shown in Figure 5-8). The CFB boiler is of pure biomass combustion with super high pressure and primary reheat. This boiler is the largest pure biomass combustion boiler in Asia, manufactured by Harbin Boiler Co., Ltd of China. The boiler passed the 168-hour operation in August 2016. The fuel is a mixture of bark, sawdust, rice husk and other biomass. The operation efficiency of the boiler is more than 92% and the availability is more than 95%. The original emission of NO<sub>x</sub> and SO<sub>2</sub> meets the local environmental protection standards. The project solves the sintering and deposition problems caused by high alkali metal content at high temperature when pure biomass is burnt, and verifies the corrosion mechanism and the effectiveness of anti-corrosion measures.



**Figure 5-8 100MW CFB with Pure Combustion Biomass (Biomass Electricity Co. Ltd. in Thailand)**

Different from the situation that most biomass resources are woody plants in the rest of the world, main biomass resource in China is agricultural waste. In view of the actual situation of biomass fuels in China, CFB boilers burning pure agricultural straw have been developed, and a large number of successful practical cases have been tested such as the 30MW unit of Qian'an Biopower Company in Songyuan City of Jilin Province (see Figure 5-9). The boiler consumes more than 30% of the corn straw in Qian'an and has operated normally since its commissioning. The boiler efficiency is 91%, and the emission of SO<sub>2</sub> is only 2.5mg/m<sup>3</sup>. Above all, it has good economic benefits. Phase II is being constructed at present.



**Fig. 5-9 30 MW CFB Boiler with Pure-fired Corn Straw (Qian'an Biopower Plant in Jilin Province)**

## References

- [1] Yue G, Li Y, Lu X, et al. The first pilot compact CFB boiler with water cooled separator in China[C] //Proceedings of the 14th International Conference on Fluidized Bed Combustion, Vancouver, 1997: 497-506.
- [2] Yue G X, Lyu J F, Xu P, et al. The up-to-date development and future of circulating

- fluidized bed combustion technology. *Electric Power*, 2016, 49(01): 1-13.
- [3] Guo Q, Zheng X S, Zhou Q, et al. Operation experience and performance of the first 300mwe CFB boiler developed by DBC in China[C]//Proceedings of the 20th International Conference on Fluidized Bed Combustion, Springer Berlin Heidelberg, 2009: 237-242.
- [4] Li Y, Nie L, Hu X K, et al. Structure and performance of a 600MWe SC CFB boiler with water cooled panels[C]//Proceedings of the 20th International Conference on Fluidized Bed Combustion, Springer Berlin Heidelberg, 2009: 132-136.
- [5] Zhu Q. Developments in circulating fluidised bed combustion [R]. copyright © IEA Clean Coal Centre. CCC/219 ISBN 978-92-9029-539-6
- [6] The world's first 600 MW circulating fluidized bed plant (Baima, China) [EB/OL]. <http://www.iea.org/tcp/fossilfuels/fbc/>.
- [7] Song C, Lyu J F, Yang H R, et al. Research and application of SC and uiltra-SC circulating fluidized bed boiler technology. *Proceeding of the CSEE*, 2018, 38(02): 338-347.
- [8] Yang H R, Zhang H, Lu J F, et al. Novel CFB Boiler Technology with Reconstruction of its Fluidization State[C]//Proceedings of The 20th International Conference on Fluidized Bed Combustion, Springer Berlin Heidelberg, 2009: 195-199.
- [9] Yang H, Yue G, Zhang H, et al. Updated design and operation experience of CFB boilers with energy saving process in China[J]. *VGB Powertech*, 2011, 91(7).
- [10] Yang S, Yang H R, Lyu J F, et al. The new generation combustion technology for energy saving circulating fluidized bed boilers. *Journal of Power Engineering*, 2009, (08): 728-732.
- [11] Li J, Yang H, Wu Y, et al. Effects of the updated national emission regulation in china on circulating fluidized bed boilers and the solutions to meet them[J]. *Environmental Science & Technology*, 2013, 47(12): 6681-6687.
- [12] Li J, Yang H, Wu Y, et al. Effects of the updated national emission regulation in china on circulating fluidized bed boilers and the solutions to meet them[J]. *Environmental Science and Technology*, 2013, 47(12): 6681-6687.



## **Chapter VI CHP Technology in China**

Following the principle of energy cascade utilization, high-grade thermal energy in CHP is first used for power generation, after which the medium- and low-grade energy is used for heating, leading to a high energy utilization efficiency<sup>[1]</sup>.

Due to the above process, CHP has significant advantages in both energy conservation and environmental protection. Except for the electric power, the coal-fired CHP plant can also provide steam and hot water for surrounding residents and industries, which can replace numerous scattered and inefficient small boilers in the heating area.

CHP has widely used in industries as well as people's lives and has comprehensive benefits including energy-saving and environment improvement. Especially in residential heating, it is a public welfare facility that can control pollutions and improve people's life quality for coal-based cities.

### **6.1 Development History and Current Status**

#### **6.1.1 Necessity of Developing CHP in China**

In China, with the rapid improvement of the national economy and the living standards, the heat demand has increased rapidly and still has a huge market in both industrial & mining enterprises and civil heating (See Figure 6-1 and Figure 6-2)<sup>[2]</sup>.

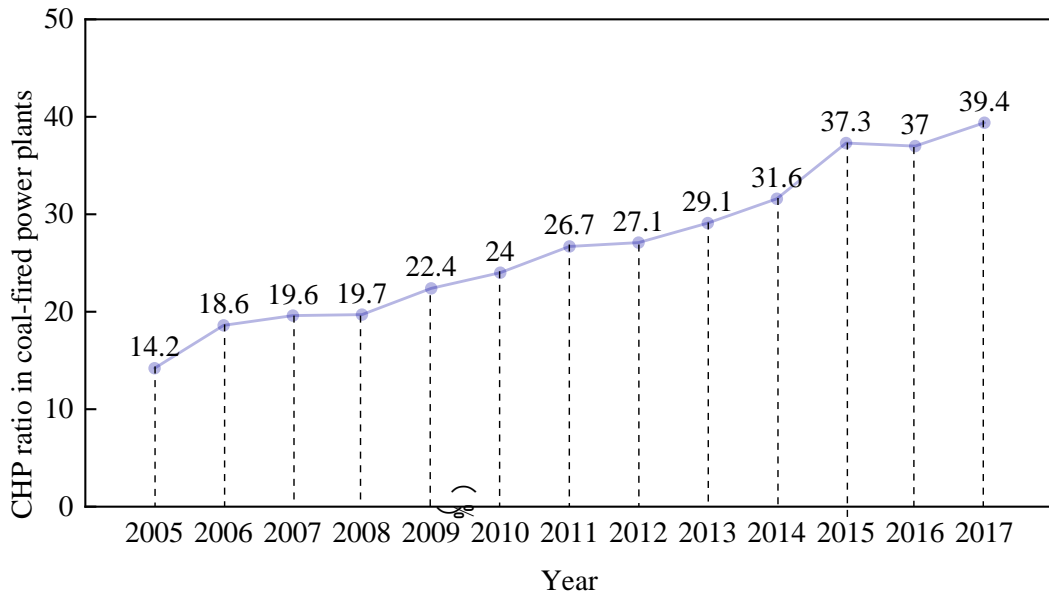

**Figure 6-1 Proportion of CHP plant in coal-fired power plant from 2005 to 2017 (Installed capacity)**

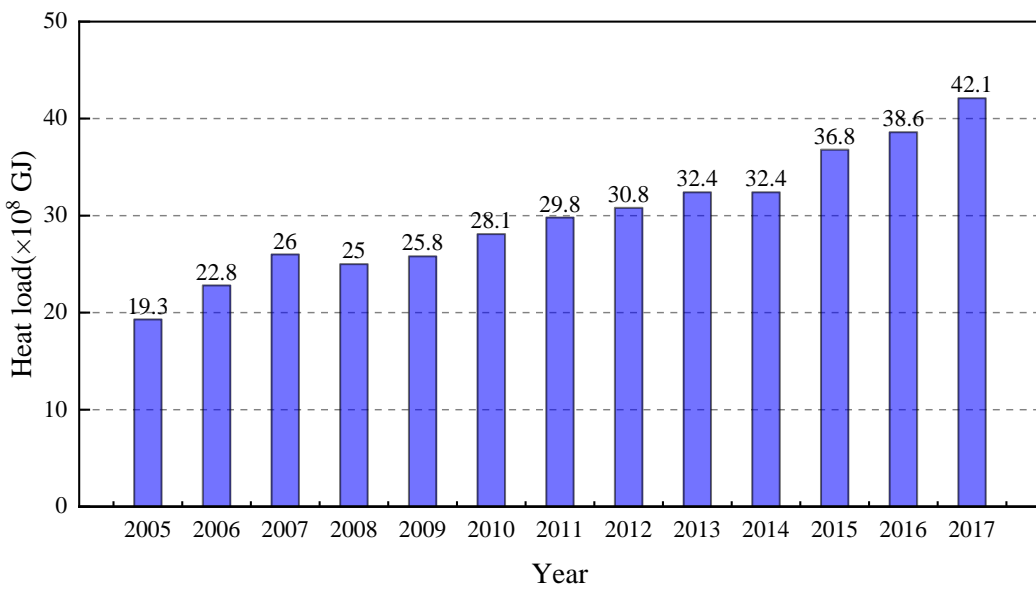
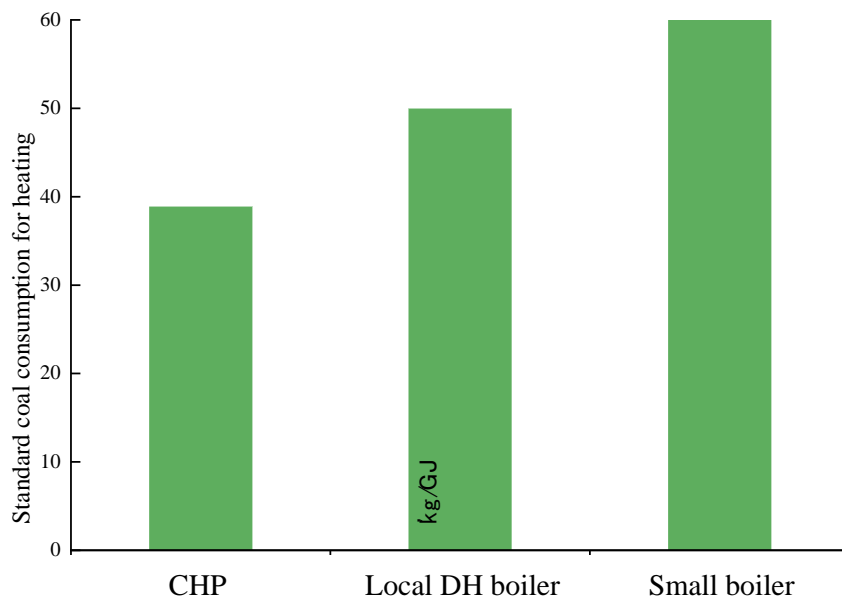

**Figure 6-2 Heat Supply of China's Heating Units from 2005 to 2017**

By the end of 2017, the total heating area in northern China is over 20 billion  $m^2$ , of which only 3.5 billion  $m^2$  is supported by district heating based on coal-fired CHP units, which means an enormous market demand for district heating [3].

Compared with regional boilers and decentralized small boilers, CHP has the advantages of energy conservation and environmental protection. The

standard coal consumption rate for heating of the coal-fired CHP is about 39.8kg/GJ, and can be reduced to 10kg/GJ for large-scale CHP plants with exhaust steam waste heat recovery, while those for regional coal-fired boilers and decentralized small boilers are about 50kg/GJ and 60kg/GJ, respectively (Figure 6-3) [4].



**Figure 6-3 Coal Consumption for Different Heating Modes**

Based on the ultra-low emission standards, the concentrations of dust, SO<sub>2</sub>, and NO<sub>x</sub> in CHP plants should be lower than 10mg/Nm<sup>3</sup>, 35mg/Nm<sup>3</sup>, and 50mg/Nm<sup>3</sup>, respectively, while dust concentration of small scattered coal-fired boilers is usually higher than 1000mg/Nm<sup>3</sup>, and the concentrations of SO<sub>2</sub> and NO<sub>x</sub> are also much higher than those of CHP units.

In addition, by reducing the loss of cold source, the CHP plant has a high energy utilization efficiency which can be more than 80% [5], much higher than the condensing unit, which is around 40%.

Therefore, clean coal CHP plant is strongly supported by the Chinese

government, to meet the residential and industrial heating demands and to eliminate and replace inefficient and highly polluting small decentralized coal-fired heating boilers. And it will help to improve the living standards as well as the atmospheric environment.

### 6.1.2 Development course of CHP

In China, with the rapid development of economy, the heat and power demand has increased dramatically. Meanwhile, the higher standards on energy-saving and environmental protection also have promoted the constant innovation of power technology. Correspondingly, CHP in China has the following stages:

Before 1980, the heat and power demand was both small and limited as the national economy was small. So, CHP plant built then was mainly 50MW or less, and only provide steam and hot water for some industries and large cities.

From 1980 to 2000, due to the growth of the national economy, heat and power demand increased fast in both industries and DH system in cities, which brought the applications of ultra-high CHP plants, including 100MW and 200MW.

Since 2000, with the acceleration of urbanization, heat demand also increased dramatically. Moreover, environmental protection has attracted more attention, and many local coal-fired boilers and scattered small boilers have been closed according to the government policy. Thus, the scales of CHP plants have become larger, including the sub-critical and super-critical plants of 135MW, 200MW, 300MW, and 600MW.

In recent years, the government has made policies to promote the CHP technology and application, such as the large-scale back-pressure technology, high back-pressure technology, retrofit technology for the existing plant, gas-steam combined-cycle and et al.

### 6.1.3 Current Status of CHP

In the past decades, a heating mode has been built for cities and industrial enterprises in China, which stands on coal-fired CHP and large boilers heating, supplemented by other clean (or renewable) energy sources and decentralized coal-fired boilers.

To provide hot steam for industrial parks and enterprises, and heating for urban residents, coal-fired CHP of 135MW, 300MW and 600MW with extraction condensing turbines are the major units, with small- and medium-sized extraction condensing units and back-pressure units below 50MW as auxiliary units.

By the end of 2017, CHP units are 435GW and account for 39.4% of installed thermal power plants in China <sup>[6]</sup>, of which the steam district heating capacity is about 120,000t/h and the hot water DH capacity is about 570GW. According to the forecast of Zero Power Intelligence Research Institute, by 2020, CHP steam heating capacity in China will reach 177,000t/h and hot water heating capacity will be 734GW.

The rapidly-developing CHP has contributed to China's national economy and society and is also an effective way to save energy and reduce emission.

## 6.2 CHP Policies and Future Directions

The Chinese government has published a series of policies to encourage the scientific development of CHP to address the problems, including air pollution, lagging development of CHP and acute regional conflict in the utilization of electricity and heat <sup>[7]</sup>.

In 2014, the *Action Plan on the Upgrading and Transformation of Coal-Fired Power Plants for Energy Conservation and Emission Reduction (2014-2020)* <sup>[8]</sup> was promulgated. In 2016, the *Administrative Measures for CHP* was revised. In 2017, the *Winter Clean Heating Plan for Northern Areas (2017-2021)* was formulated, which put forward stricter requirements on the energy consumption limits and pollutant emission limits of thermal power plants and required the retrofit of units in progress for energy conservation and emission reduction. The introduction of these policies has prompted cities to pay more attention to energy conservation and emission reduction and heating distribution. Many local thermal network plans and CHP plans have been proposed, which have promoted the rapid progress of CHP technology.

The main future directions of CHP supported by the government are as follows <sup>[9]</sup>

- (1) Support the construction of back-pressure units and strictly control the construction of new extraction condensing thermal units.
- (2) Support regional CHP projects and limit the construction of single enterprise-owned CHP projects.
- (3) Retrofit existing condensing units by such mature and applicable technologies such as air extraction by perforation, low vacuum heating, and utilization of waste heat produced by circulating water for district heating.

(4) Expand the heating range of CHP units and develop long-distance heating technology.

(5) Retrofit CHP units by the technology of waste heat recovery to further improve district heating capacity.

(6) Utilize various forms of clean and renewable energy for heating such as waste heat, residual pressure, biomass energy, geothermal energy, solar energy, and gas.

(7) Construct distributed energy projects and achieve cascade energy utilization through CCHP technology. The technology integrates refrigeration, heat supply, and power generation, and is usually composed of a generator set, a lithium bromide absorption chiller (using cold/ hot water) and a heat exchanger. High-grade thermal energy is used for power generation, while low-grade energy is used for heating and cooling. It is a small distributed station for cooling, heating and power generation.

(8) In developed and seriously polluted areas, combined gas-steam cycle CHP plants should be developed, and coal-fired CHP projects should be restricted.

(9) According to the “ordering power by heat” principle, power generated by CHP units shall take the priority to be purchased by power grid enterprises, which shall be promoted under the supervision of related departments with respect to grid connection, dispatch priority and the mode of ordering power by heat.

### **6.3 Principal CHP technologies in China**

According to policies on energy conservation and emission reduction, waste heat recovery, and heat capacity expansion, CHP technologies in China have been well developed in the past decades (See Figure 6-4). There are two directions of CHP technologies that concern the new-built and existing power plant, respectively.

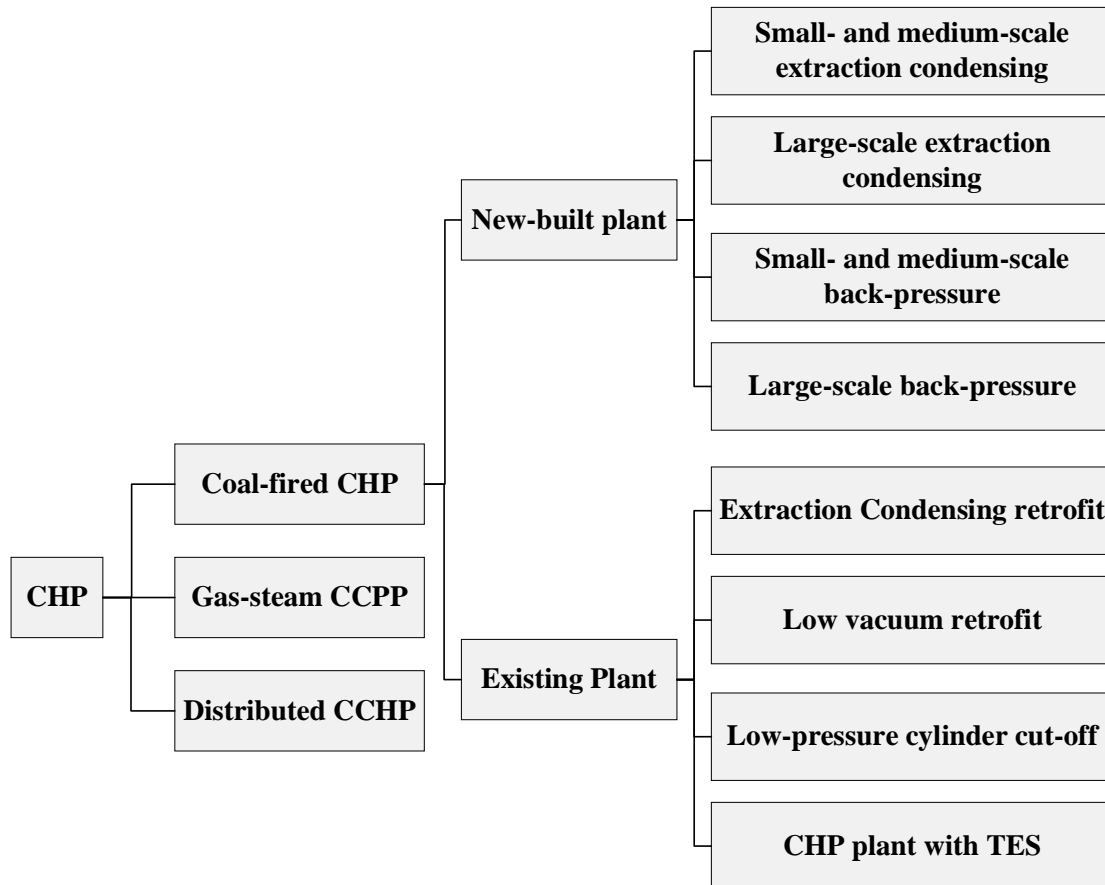

**Figure 6-4 Main Technical Road Map of CHP**

### 6.3.1 Extraction Condensing Technology

In the extraction condensing steam turbine, part of the steam is extracted after expansion in the high- and medium-pressure cylinders, which can reduce the exhaust steam to the condenser and provide steam at an intermediate temperature and pressure for the DH system and industrial process.



In the extraction condensing CHP plant, the power will vary depending on the amount of the extracted steam. This makes for a flexible plant which power and heat load can be balanced depending on the demand, and suitable for the area where heat and power demand changed frequently.

(1) Small- and medium-scale extraction condensing technology

Small- and medium-scale extraction condensing technology can be used in the district where heat and power demand changed fast, such as the small- and medium-sized DH system and industrial process, the industrial park and enterprise-owned CHP station.

According to the heat consumers, the steam turbine that only provides steam for industries or hot water for the DH system can be classified as single extraction condensing steam turbines (C-Type). And steam turbine that provides both steam for industries and hot water for DH system is double extraction condensing steam turbines (CC-Type). Table 6-1 shows the typical extraction condensing steam turbines with C-Type and CC-Type.

**Table 6-1 Type C/CC Extraction Condensing Heating Model**

Types	C- Type	CC-Type
Capacity range (MW)	3~55	3~55
Main steam pressure range (MPa)	3.43~8.83	3.43~8.83
Main steam temperature range (°C)	435~535	435~535
Extract steam pressure range (MPa)	0.118~1.57	0.118~1.57

Manufacturers in China can produce a complete series of small- and medium-scale extraction condensing steam turbines. A single steam turbine can serve the area with power demand of less than 55MW, industrial steam of less than 210t/h, and heating area of less than 6 million m<sup>2</sup>. Customers can select models from product series based on power and heat demand.

The extraction condensing steam turbine can meet the changing heat and power demand in time. When the heat load increases, the main steam mass flow of the turbine can be adjusted accordingly. After serving the heat consumer, part or all the condensed water is recycled to the drain reclaimer in the CHP plant, which can be used in the boiler circulating water system.

(2) Large-scale extraction condensing technology

300MW and 600MW CHP plants with sub-critical and super-critical parameters can be used to provide heat, steam, and power for large cities and industrial parks, and have become the major types of new-built CHP units in China. The process is shown in Figure 6-5.

Large-scale extraction condensing steam turbine is usually developed based on the specific demand and conditions. The extracted steam of the medium-pressure and low-pressure cylinders are designed according to the requirement of customers, thus improving economic performance. The rotating clapboard or a steam regulator after the extraction port is used to ensure the efficiency of the CHP plant.

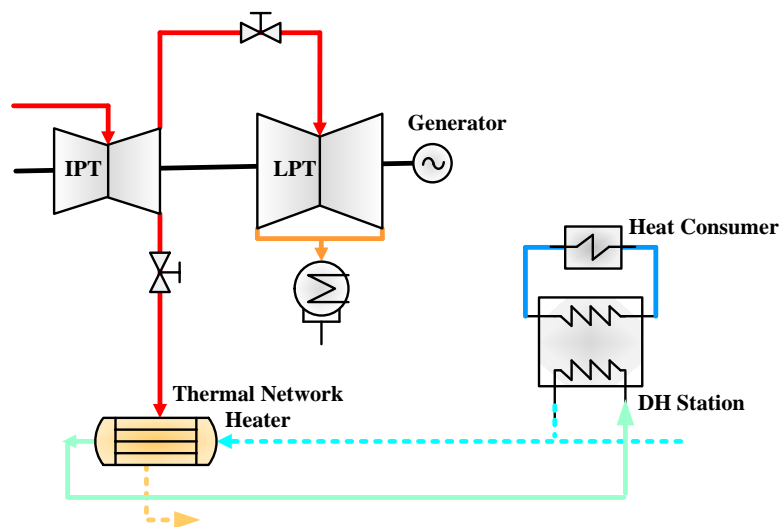

**Figure 6-5 System diagram of high temperature, pressure and capacity extraction condensing heating units**

Large-scale extraction condensing CHP plant usually has a higher efficiency, power and heat capacity as well as the better operational performance. Based on the specific operational demand, it has several operational modes to provide the heat and power load, making the operational dispatch more flexible, convenient and reliable.

In a 600MW extraction condensing CHP plant, whose rated power is 600MW and the steam parameters are 24.2MPa(a)/566 °C /566 °C , the designed and maximum mass flow of the extract steam are 800t/h and 900t/h, respectively. The extracted steam parameters are 1.0MPa/340.9°C, and the heat-power ratio can reach 134.3%, which can provide industrial steam of 900t/h or cover the DH system of about 14 million m<sup>2</sup>.

### 6.3.2 Back-pressure technology

In the back-pressure steam turbine, the steam exiting the turbine exhaust still contains a significant amount of energy with relatively high pressure and temperature and can cover the DH system in direct or indirect methods. That means the exhaust steam is used as heat source, shown in Figure 6-6.

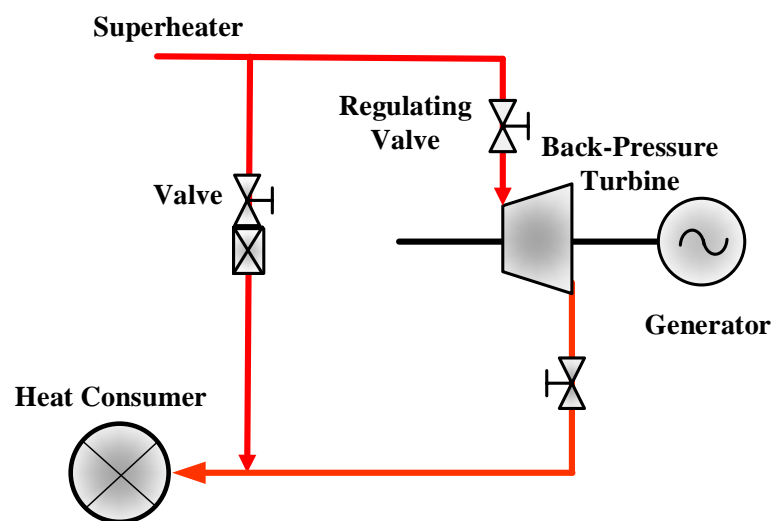

Figure 6-6 System diagram of BP-DH units

Compared with extraction condensing CHP plant, the back-pressure CHP plant is more suitable for areas where the heat load is the main demand with small adjustments. The operation mode must change accordingly with the heat load, so the power load cannot follow power grid requirements.

#### (1) Small- and medium-scale back-pressure technology

Small- and medium-scale back-pressure technology can be used in the small- and medium-sized DH system and industrial process, industrial parks and enterprise-owned CHP stations.

Back-pressure turbines have two common types which are the pure back-pressure type (B-Type, heat supplied by exhaust steam only) and the extraction BP back-pressure (CB-Type, heat supplied by both extracted and exhaust steam).

The back-pressure steam turbine has no cold source loss in the condenser, leading to a low standard coal consumption rate for power generation and therefore is economically optimal. The operation of the back-pressure steam turbine follows the mode of ordering power by heat (the power load is determined by the heat load), so the power and heat load cannot be adjusted separately. The turbine cannot operate without the heat load. If the heat load increases, the main steam will increase accordingly, leading to the increment of power load.

Industry in China can produce a complete series of small- and medium-scale back-pressure steam turbines. A single steam turbine can serve the area with a power demand of less than 55MW, industrial steam of less than 475t/h, and heating area of fewer than 8 million m<sup>2</sup>.

**Table 6-2 Type B/CB BP-DH Models**

Types	B-Type	BC-Type
Capacity range (MW)	3--55	3--55
Main steam pressure range (MPa)	2.35-8.83	2.35-8.83
Main steam temperature range (°C)	300-535	300-535
Extract steam pressure range (MPa)	0.29--1.28	0.29--1.28

## (2) Large-scale back pressure technology

A large-scale back pressure CHP plant can provide steam and hot water for a large city and industrial parks, and it has been developed fast in recent years. The capacity has changed from the ultra-high plant of 25MW and 50MW to super-critical CHP plant of 300MW, which has the higher heat capacity and energy utilization efficiency and can meet the higher heat demand.

### 6.3.3 Retrofit technologies for the existing plant

#### (1) Extraction Condensing retrofit technology

With the development of China's economy, some power plants built early cannot meet the energy demand because both the heat and power loads have changed dramatically. Meanwhile, along with the new policies concerning energy conservation, emission reduction and efficiency improvement proposed by the government, many power plants with different capacities (Including 125MW, 200MW, 300MW and 600MW) are required to serve the DH system, which means they should transfer their mode from power-only to power & heat, or even the mode of ordering power by heat. The objective of the retrofit is to reduce the cold source loss and the coal consumption rate and to increase the gross efficiency or the heat capacity. The retrofit of the power plants usually has a deadline, which

promotes the DH retrofit technology for coal-fired power units.

The selection of DH retrofit technology is usually based on the comprehensive techno-economic analysis, which concerns the power plant, heat load demand, parameters of the DH system, the layout of steam turbines, and the retrofitting investment and benefit.

There are three general extraction sources for the DH retrofit: (1) from the pipe between the medium- and low-pressure cylinders; (2) from the cold pipe of reheat steam; (3) from the port perforated in the medium-pressure cylinder. If the extracting steam has a much higher pressure than the DH system needed, a back-pressure turbine can be used to recover some waste heat to improve the energy utilization efficiency <sup>[11]</sup>. Table 6-3 shows the heating capacity and conditions of retrofitted units.

**Table 6-3 Heating capacity and conditions of retrofitted units**

Capacity (MW)	Extraction pressure (MPa)	Extraction temperature (°C)	Maximum extraction capacity (t/h)	Notes
125	0.25	~250	200	Old type
	0.7~1.0	~260	200	New type
200	0.245	~245	150~200	3-exhaust
	0.245	~245	400	2-exhaust
300	0.7~0.9	310~350	500	Harbin, Shanghai, East
	0.3~0.6	205~250	600	Beizhong
600	0.7~1.0	310~360	800	

**Retrofit case based on a power plant with 600MW sub-critical condensing steam turbine:**

A power plant with two 600MW condensing units was retrofitted to serve

the DH system. The turbine is N600-16.7/537/537, reactionary type with single-shaft, 8-stage extraction, 4-cylinder, and 4-exhaust steam. The main steam parameters are 16.7MPa/537°C, with the rated mass flow of 1806t/h. The reheat steam temperature is 537°C, and back-pressure of the exhaust steam is 4.9kPa.

### **The main retrofit plan:**

The high- and low-pressure cylinders remain unchanged. After the strength check of the last four stage blades of the medium-pressure cylinder, a three-valve is added on the pipe between the medium- and low-pressure cylinders for steam extraction and a butterfly valve is set between the three-valve and thermal network heater to adjust the steam pressure; the heating steam extraction pipeline is led out from the three-way pipe and from the side of column A above the turbine operation platform layer. Check valves, throttle valves, fast cut-off valves, and relief valves are installed on the extraction pipeline.

### **Main parameters after retrofit:**

Designed heat load conditions: Parameters of the main and reheat steam remain unchanged; the main steam mass flow is 1900t/h; the output power is 450.8MW; the extract steam mass flow is 900t/h; the parameters of the extract steam are 0.94MPa/340.9°C; the heat load is 2180GJ; and the heat-electricity ratio is 134.3%.

Maximum heat load conditions: Parameters of the main and reheat steam remain unchanged; the main steam mass flow is 2023t/h; the output power is 460.41MW; the extract steam mass flow is 1000t/h; the parameters of the extract steam are 0.94MPa/340.9°C; the heat load is 2408GJ; and the

heat-electricity ratio is 144%.

After the retrofit of the CHP plant (N600-16.7/537/537), restricted by the blade strength of the medium-pressure cylinder and the flow rate of the extraction pipeline, the adjustment range of the extract steam pressure is usually narrow and maintains between 0.89MPa and 0.94MPa with the temperature from 341.3°C to 340.9°C to ensure the safe operation of the CHP plant.

After the retrofit, the CHP plant can serve the DH system of about 15 million m<sup>2</sup>.

## **(2) Low vacuum retrofit technology**

Low vacuum technology can further reduce the cold end loss of condensing units, and explore the waste heat recovery potential, which can be used to expand the heat capacity of existing plants. And it has been widely used in retrofit programs in China.

In the heating period, the pressure of the low-pressure cylinder can be improved by reducing the vacuum level of the condenser. Then the exhaust steam or the circulating water of the CHP plant can be used as the heating source of the DH system. In this process, the waste heat of the exhaust steam is recovered and the cold source loss is reduced, thus improving the overall efficiency and energy utilization ratio. The common forms of the low vacuum technology are listed as following:

### 1) Low vacuum technology for direct heating



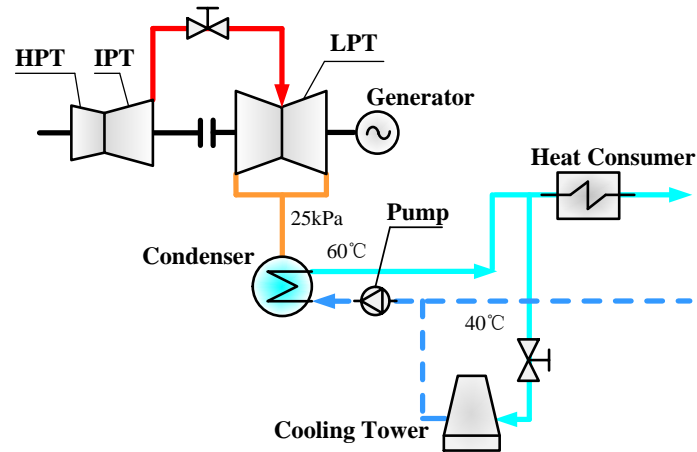

**Fig 6-7 Diagram of LV-DH System**

This technology is suitable for areas with small heat load and short heating distance and is usually applied to plants with small capacity. The temperature of the exhaust steam can be increased along with the improvement of the back pressure, then the thermal network water can be directly heated to 60°C-70°C by the exhaust steam, shown in Figure 6-7.

## 2) Low vacuum-based cascade heating technology

This technology is generally used for waste heat recovery in the extraction condensing CHP plant to improve heat capacity, as shown in Figure 6-8.

By increasing the back-pressure of the CHP plant, the waste heat of the exhaust steam can be recovered, and the condenser can be used as a pre-heater for the thermal network water. After the preheating, the thermal network water needs to be further heated by the thermal network heater driven by the extract steam. Compared with the traditional extraction condensing technology, cascade heating technology can increase the heat capacity by more than 30%, and the primary energy utilization efficiency can reach 90% [12].

Recently, low vacuum-based cascade heating technology has been widely applied in dozens of 300MW power plants in China to reduce the coal consumption rate. These plants have played an important role in the DH system and eased the shortage of heat sources. Meanwhile, they have replaced many small boilers with large pollutant emissions, improved the environment, and brought significant social and economic benefits.

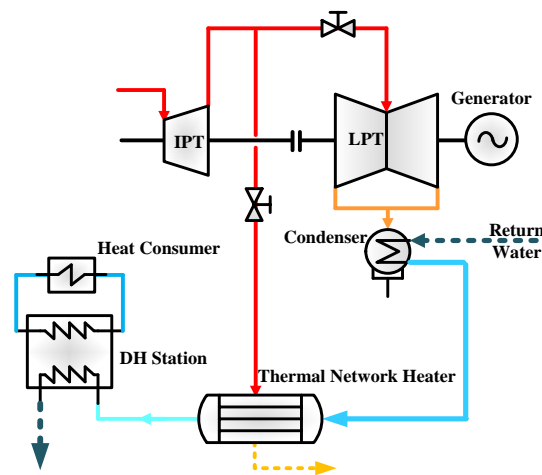

**Fig 6-8 Cascade heating system based on waste heat recovery of HBP turbines**

### (3) Low-pressure cylinder cut-off technology

Low-pressure cylinder cut-off technology is suitable for the CHP plant which has a great demand on peak shaving. The technology can provide a large heat load with a low power load. And it also needs strict monitoring of the operation of the steam turbine. In 2018, there are more than 10 power plants which have applied this technology and operated successfully.

In the low-pressure cylinder cut-off technology, the low-pressure cylinder operates under the high vacuum condition. And the steam used to the low-pressure cylinder is almost cut-off and only a little is left as the cooling steam <sup>[13]</sup>. By doing this, the low-pressure cylinder maintains 3000rpm operation with “zero” power output. And steam to DH system is increased,

leading to higher heat capacity and lower power output <sup>[14]</sup>.

#### **(4) CHP plant with the thermal energy storage**

A large hot water tank can be installed in the CHP plant, which can store the surplus heat in the day with high power load and release heat in the night with low power load. By doing this, it can provide an auxiliary heat source to meet the heat demand when the CHP plant operates with a low power load. It can improve the flexibility of the CHP plant and make the CHP plant easier to follow the power dispatch.

In addition, CHP plants can also choose the combined technology based on their actual demand.

### **6.4 Typical CHP Cases**

#### **6.4.1 CHP plant in Light Industrial Park, Hailun**

In the Light Industry Industrial Park, Hailun (Heilongjiang Province), the CHP plant provides industrial steam and power for the production of 300,000-ton ethanol and 6 other small and medium-sized enterprises. The average heat load is 173t/h in summer and 242t/h in winter (including 15t/h for DH system)

##### **(1) Installation plan**

The CHP plant involves three 130t/h CFB boilers with high temperature and pressure (2 operating boilers and 1 standby boiler), and one 30MW back-pressure steam turbine. The Boiler Maximum Continuous Rating (BMCR) of the boilers is 130t/h, and the maximum rating of 143t/h with rated steam parameters of 9.81MPa/540°C. The steam turbine adopts the

back-pressure type (B30-9.81/0.981), with the rated power of 30MW, the rated main steam temperature and mass flow of 535°C and 231.5t/h, the maximum main steam mass flow of 260t/h, and the exhaust steam back-pressure and temperature of 0.981MPa and 285°C, respectively.

(2) Project achievements:

The CHP plant in Hailun provides an annual power and heat load of  $2.2507 \times 10^8$  kWh and  $394.12 \times 10^4$  GJ with the average efficiency and of 75.81%. The average standard coal consumption rate for power generation and for heating are 154g/kWh and 39.85g/kWh, respectively, with the average heat and power ratio of 630%. The CHP plant can meet the industrial steam demand of 7 small and medium-sized enterprises in the industrial park, and solve the pollutant emission problem by replacing 2 small coal-fired powerhouses and 8 small heating boilers. It can reduce environmental pollution and improve energy utilization efficiency.

#### 6.4.2 Low vacuum retrofit technology in the CHP plant, Guodian Dalian

The CHP plant of Guodian Dalian is located in the Economic and Technological Development Zone, Liaoning Province. Built in 1990, it has two 350MW SC extraction condensing steam turbines (NC350-24.2/0.4/566/566), which are manufactured by Beijing Heavy Machinery Factory, with a designed extract steam mass flow of 500t/h and a heating area of 8.6 million m<sup>2</sup> per unit.

To serve the new-built town and protect the environment in the development zone, the CHP plant needed to increase the heat capacity and replace some coal-fired boilers which supply industrial steam inefficiently

and with high pollution.

Therefore, the CHP plant performed a series of retrofits from 2016 to 2017, including the exhaust steam waste heat recovery, the addition of the industrial steam, bypass system, and heat-power decoupling, which aims to increase heat capacity and flexibility, further improve the energy utilization efficiency and cover the growing heat demand.



**Figure 6-9 A Bird View of Dalian Development Zone Power Plant**

(1) Exhaust steam waste heat recovery <sup>[15]</sup>

In 2016, low vacuum technology was applied to Unit 1#. The back-pressure could reach 34kPa in the heating period and remain at 10kPa in non-heating seasons. During the heating period, Unit 1# operates with low vacuum when Unit 2# operates under the original back-pressure. And the thermal network water is heated by the exhaust steam of Unit 1# and extract steam of Unit 2# consequently. In this process, the waste heat of Unit 1# is fully used, and the extract steam of Units 1# and 2# is reduced, thus improving the energy utilization efficiency.

Project achievements: the heating capacity of Unit 1# is increased to

1785GJ/h. Compared with the original, the heating area is increased by 3.5 million m<sup>2</sup>, and the average coal consumption rate and heat consumption rate are decreased by 84.2g/kWh and 2148.4kJ/kWh during the heating period, which reduces the standard coal consumption by 98,200 tons per year.

**Table 6-4 Conditions comparison of Unit 1# before and after Retrofit**

Items	Unit	Before retrofit	After retrofit
Main steam mass flow	t/h	1067	1067
Power per unit	MW	270.23	284.89
Coal consumption rate	g/kWh	213.87	135.08
Maximum heating capacity	GJ/h	1271.0	1785.1
Maximum heating area per unit	million m <sup>2</sup>	8.60	12.10

(2) Retrofit for the industrial steam supply

To replace small boilers with high pollution, the CHP plant has been retrofitted in 2017 to supply industrial steam for the park. The four-stage extract steam and the reheat steam are mixed by a pressure matcher and then delivered as the industrial steam.

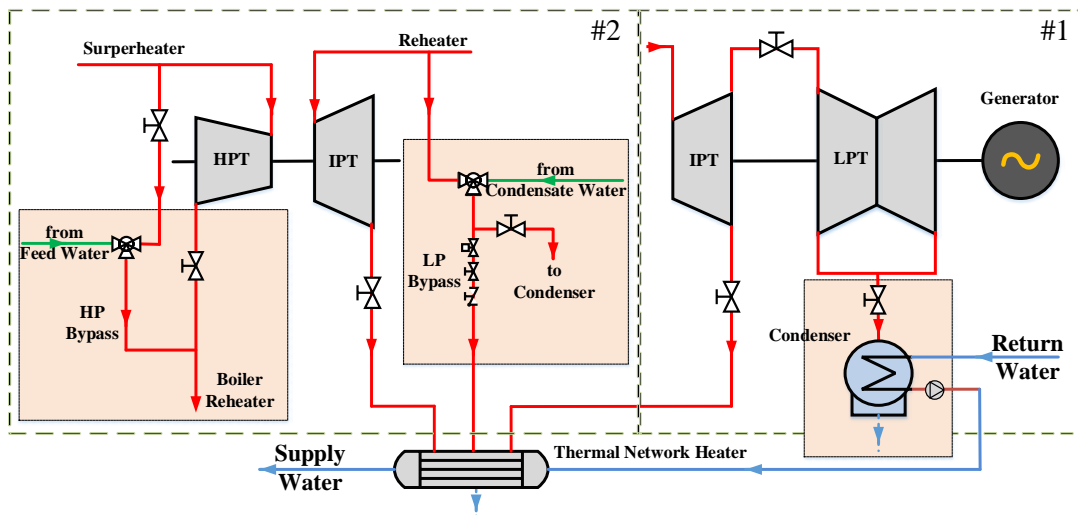

**Fig 6-10 System Chart of Dalian Development Zone Power Plant**

After the retrofit, the industrial steam mass flow of a single unit is 120t/h,

with the pressure and temperature being 1.2MPa/250°C. The four small boilers in the surrounding area are replaced, which has a positive impact on the environment and also brings great benefits to the company.

### (3) Turbine bypass system –heat-power decoupling

To improve the peak shaving capability, the CHP plant has conducted a retrofit using high- and low-pressure bypass system in 2017. After the retrofit, the plant can operate under 20% load stably and continuously with the heat supply. It means that the two units can participate in the deep peak shaving of the power grid during the heating period.

Project achievements: After the flexibility retrofit, the power and heat load range of Unit 2# has been expanded. The power load ratio can be steadily reduced to 19.4% with a DH area of 13 million m<sup>2</sup>, which means that the peak shaving capability of the plant is significantly enhanced.

The retrofit is successful and of great value, for it has paved the way for the technological development of CHP units and played an exemplary and leading role for the same-type power plants.

### 6.4.3 2×660 MW CHP plant in Dianta

The coal-fired power plant in Dianta was built in 2015 and has 2×660MW SC air-cooled units. The steam turbine is SC, single-shaft, 3-cylinder with 4-exhaust with one intermediate reheat. The main steam flow rate under the THA condition is 1913.1t/h, and the steam parameters are 24.2MPa/566°C/566°C. The steam turbine was supplied by Harbin Steam Turbine Factory Co., Ltd.

Due to the local economic development and the demand of the DH system,

the power-only plant needs to be retrofitted to the CHP plant, which becomes a centralized heat source serving the DH system of 10 million m<sup>2</sup> in Shenmu and 2 million m<sup>2</sup> in Dianta. After the retrofit, the CHP plant would support the DH system and replace many heating boilers which are highly-pollutant, scattered, small and inefficient.

#### (1) The technical solution for DH retrofits

The high- and low-pressure cylinders remain unchanged. After the strength check of the last four stage blades of the medium-pressure cylinder, a three-valve is added on the pipe between the medium- and low-pressure cylinders for steam extraction and a butterfly valve is set between the three-valve and thermal network heater to adjust the steam pressure; the heating steam extraction pipeline is led out from the three-way pipe and from the side of column A above the turbine operation platform layer. Check valves, throttle valves, fast cut-off valves, and relief valves are installed on the extraction pipeline. After the retrofit, the maximum extraction capacity is 600t/h per unit, the heating load is 780MW, and the heating extraction conditions are 0.64MPa/360°C. The extraction pipelines of the two units are combined first, and then connected to the new-built primary thermal station.

In the primary thermal station, there are 4 heaters, 4 circulating water pumps, 2 drain coolers, and 2 water supply pumps. The drain coolers drain water to the hot well of the steam turbine exhaust device. The temperatures of supply/return water in the primary thermal network are 120°C/60°C, respectively.

Although extraction parameters are relatively high, no back-press turbine is added to recover the power due to the restriction of layout conditions.



## (2) Retrofit results

After the retrofit, when the extraction volume is 600t/h, the turbine power is 525MW. Meanwhile, the standard coal consumption rate for power generation and for power supply are reduced to 282g/kWh and 309.6g/kWh. 169 small heating boilers are replaced, which reduce SO<sub>2</sub> by 1700t/a, dust by 320t/a and NO<sub>x</sub> by 1350t/a. The CHP retrofit improves energy utilization efficiency as well as the urban environment.

### 6.4.4 2×150MW Power plant, South Sumatra in Indonesia

#### (1) Brief introduction

Guohua (Indonesia) power plant is located in Simpang Belimbing, Muara Enim, South Sumatra, Indonesia, which is about 100km from Palembang. The power plant had two 150MW units, which first operated on July 6 and November 3 in 2011, respectively, and operated commercially on February 27, 2013.

The power plant is a coal and electricity integrated IPP (Independent Power Producer) project invested by the China Energy (the former Shenhua Group), which adopts the BOO mode and has a contract period of 30 years. The registered company, PT.GH EMM Indonesia is a joint venture between the former China Shenhua (70%) and PT Energy Musi Makmur (30%) with a total investment of 380 million US dollars. The project has set many new records for power plant construction in Indonesia. It is the first power plant in Indonesia that has successfully used inferior lignite fuel and is also the first IPP power plant in Indonesia that has generated power ahead of the PPA schedule.

## (2) Technical Features

Based on the integration technology of “pre-drying + medium speed pulverizer + pulverized coal furnace” for ultra-high moisture lignite, local lignite fuel with a moisture content of 60% or above can be used in the power plant. The annual average operating time of the plant is more than 7800 hours. In this project, the extract steam of the turbine is used as the heat source for lignite drying, which reduces both the cold source loss and the moisture content of lignite and further improves the boiler efficiency. Compared with the fan pulverizer, the standard coal consumption rate can be reduced by about 10g/kWh. By the end of 2018, the power plant with lignite drying has been operating safely and stably for more than 7 years, with an average equivalent available coefficient of 98%. And the continuous operation performance is far better than the requirements of Indonesia’s power grid test.

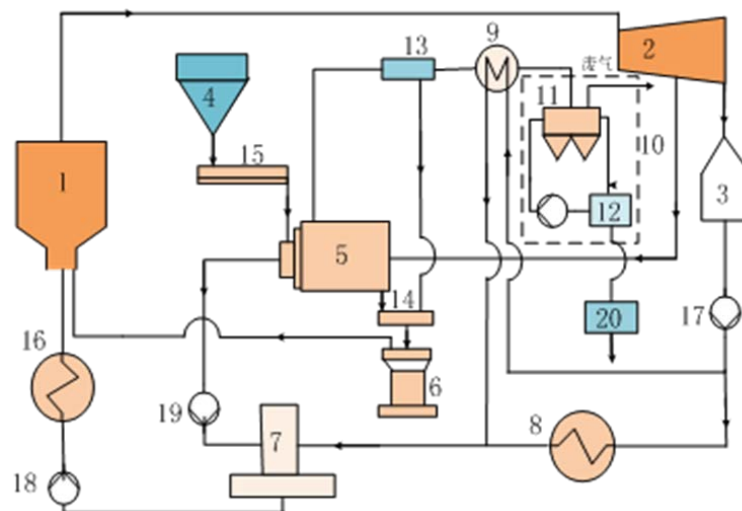

**Fig 6-11 Flow Chart of the Power Station**

1-boiler; 2-turbine; 3-condenser or air cooler; 4-wet lignite bunker; 5-drying device; 6-pulverizer; 7-deaerator; 8-low-pressure heater ; 9-heat recycling device; 10-water recycling device; 11-wet precipitator; 12-sedimenting device; 13-filter device; 14-dry lignite feeder; 15-wet lignite

feeder; 16-high-pressure heater ; 17-condensing water pump; 18-water feed pump; 19-condensate pump; 20- sewage treatment device.

### (3) Project achievements

The power station was awarded the Golden Flag Certificate of SMK3 in 2015, thus becoming a model for China Energy's construction and operation in Indonesia. The project has been highly recognized by the Indonesian President, local government and industry regulatory departments for demonstrating and promoting clean and efficient power generation solutions for ultra-high moisture lignite and for promoting the progress of related equipment manufacturing industry.

### References

- [1] Song Zhiping, Wang Jiakuan. Principle of energy conservation [M]. Beijing: China Water Power Press, 1985: 215-230.
- [2] China Electricity Council, China Coal Power Clean Development Report [M]. Beijing: China Electric Power Press, 2017.
- [3] National Development and Reform Commission, National Energy Administration, Ministry of Finance, etc. Winter Clean Heating Planning in the North (2017-2021) [Z]. 2017-12-20.
- [4] Energy consumption limit for cogeneration unit products: GB 35574-2017 [S], 2017.
- [5] Ghorbani, Naser. Combined heat and power economic dispatch using exchange market algorithm [J]. International Journal of Electrical Power & Energy Systems, 2016, 82: 58-66.
- [6] China Electricity Council. China Power Industry Annual Development Report 2018 [J]. China Power Enterprise Management, 2018, No. 529 (16): 13-14.
- [7] National Development and Reform Commission, National Energy Administration, Ministry of Finance, etc. Cogeneration management measures [Z]. March 22, 2016
- [8] National Development and Reform Commission, Ministry of Environmental Protection, National Energy Administration. Coal-fired energy-saving emission reduction upgrade and transformation action plan (2014-2020) [Z]. September 12, 2014.
- [9] Yang Xuzhong, Guo Xiaoke, Kang Hui. Cogeneration Planning and Design Handbook Beijing: China Electric Power Press, 2009.
- [10] China Association of Science and Technology. 2014 - 2015 Power and Electrical Engineering Discipline Development Report [M]. China Science and Technology Press, 2016.

- [11] Ge Zhihua, Yang Jialin, He Jianren, et al. Energy-saving research on large-scale condensing turbine heating reform [J]. Chinese Journal of Electrical Engineering, 2012, 32 (17): 25-30.
- [12] Ge Zhihua, Sun Shimeng, Wan Yan, et al. Applicability analysis of high back pressure heating for large steam turbines [J]. Proceedings of the China Electrical Engineering, 2017 (11): 162-168 + 323.
- [13] Yang Rongzu, Song Wenxi, Sun Qide, et al. A low-pressure cylinder long blade cooling system based on steam pump steam exhaust: China, 201710385756.6 [P]. July 28, 2017.
- [14] Ye Xiangdong, Zhao He, Luo Faqing, et al. A heating system and method for cutting low pressure cylinder steam inlet: China, 201710386956.3 [P]. August 4, 2017.
- [15] Zhihua G, Fuxiang Z, Shimeng S, et al. Energy analysis of cascade heating with HBP large-scale steam turbine[J]. Energies, 2018, 11(1):119-132.

## **Chapter VII Flue Gas Pollutant Control Technologies in China**

Coal-fired power plants used to produce a large amount of flue gas pollutants in combustion. In the process of their treatment, some air pollutants would also be produced, including particulate matters and gaseous pollutants composed predominantly of dust, SO<sub>2</sub> and NO<sub>x</sub>. In the past 30 years, China has made significant progress in flue gas pollutant control technologies, especially those of dust, SO<sub>2</sub> and NO<sub>x</sub>.

Facing increasingly regional ecology and environment problems, the Chinese government has formulated and issued a series of stricter policies, regulations and standards to control the flue gas pollutants of coal-fired power plants in recent years. In 2014, China proposed the most stringent requirements in its history, requiring coal-fired power plants achieve the “ultra-low emission” of dust, SO<sub>2</sub> and NO<sub>x</sub>, which prompted coal-fired power companies to keep adopting the latest and most advanced pollution control technologies and pushing forward the continuous and rapid development of new control technologies for air pollutants in China.

To achieve ultra-low emission, China’s coal-fired power companies have developed and applied multiple efficient air pollutant control technologies to achieve the further removal of dust, SO<sub>2</sub> and NO<sub>x</sub>. The large-scale

application of these technologies has made a significant contribution to resolving the air pollution from coal-fired power and realizing the clean coal utilization.

This chapter focuses on the development and application of ultra-low emission control technology for flue gas pollutants in coal-fired power plants.

## **7.1 Background**

The coal-fired power industry has supported the rapid economic and social development in China, but also caused air pollution, which has a certain impact on the ecological environment and human health.

In 2011, the Chinese government issued a new version of *Emission Standard of Air Pollutants for Thermal Power Plants (GB 13223-2011)*<sup>[1]</sup>, which significantly raised the emission standard of air pollutants for coal-fired power plants and regulated the emission limit of mercury (Hg) and its compounds for the first time. Although the new standard is the most stringent one on record, coal-fired power remains one of the main sources of air pollutants in China. In accordance with the statistics from China Electricity Council (CEC)<sup>[2]</sup>, China's thermal power industry that mainly used coal for power generation emitted 1.51Mt dust, 8.83Mt SO<sub>2</sub> and 9.48Mt NO<sub>x</sub> respectively in 2012, accounting for 12.2%, 41.7% and 40.6%

of China's total emissions respectively. To achieve the deep reduction of air pollutants in coal-fired power industry, enterprises represented by China Energy have taken the lead in the R&D and engineering demonstration of efficient control technologies for dust, SO<sub>2</sub>, NO<sub>x</sub> and Hg, which has promoted the formulation of national policies and the large-scale implementation of ultra-low emission.

In 2014, the Chinese government further issued the *Action Plan for the Upgrading and Retrofit of Coal-Fired Power Plants for Energy Conservation and Emission Reduction (2014-2020)*, which firstly required that coal-fired power plants should basically reach the ultra-low emission limits for gas turbine units in their air pollutants emission, *i.e.* the emission concentrations of dust, SO<sub>2</sub> and NO<sub>x</sub> should be no higher than 10mg/m<sup>3</sup>, 35mg/m<sup>3</sup> and 50mg/m<sup>3</sup> respectively at the baseline oxygen content of 6% (Table 7-1). Compared with the *Emission Standard of Air Pollutants for Thermal Power Plants (GB 13223-2011)* issued in 2011, the emission standards of dust, SO<sub>2</sub> and NO<sub>x</sub> have been significantly raised, reaching or surpassing those of developed economies, such as the EU, the United States and Japan.

**Table 7-1 Emission limits of air pollutants for domestic and foreign coal-fired power plants**

Pollutants	Application conditions	Unit	Emission limits (mg/m <sup>3</sup> )				
			<i>Emission Standard of Air Pollutants for Thermal</i>	<i>Ultra-low emission</i>	The EU	The Unite	Japan

			<i>Power Plants (GB 13223-2011)</i>	(2014)		d States	
Dust	All	mg/m <sup>3</sup>	30	10	30	12	50
	Key areas	mg/m <sup>3</sup>	20				
SO <sub>2</sub>	New boilers	mg/m <sup>3</sup>	100	35	200	130	200
	Existing boilers	mg/m <sup>3</sup>	200				
	Key areas	mg/m <sup>3</sup>	50				
NO <sub>x</sub>	All	mg/m <sup>3</sup>	100	50	200	91	200
Hg	All	μg/m <sup>3</sup>	30			0.4~6	

Guided and supported by national policies, the ultra-low emission retrofit of coal-fired power plants has entered a stage of fast implementation, with great success achieved in the reduction of air pollutants emission. The emissions of dust, SO<sub>2</sub> and NO<sub>x</sub> in 2017 decreased by 83%, 86% and 88% respectively from 2012, and coal-fired power has no longer been the major contributor to regional environment pollution in China.

## 7.2 Main Technical Routes for Flue Gas Pollutant Control

Based on research, demonstration and engineering practices, the Chinese government issued the *Guideline on Available Technologies of Pollution Prevention and Control for Thermal Power Plants (HJ 2301-2017)*<sup>[3]</sup> and *Technical Specifications for Flue Gas Treatment Engineering of Coal-Fired Power Plants Under Ultra-Low Emission (HJ 2053-2018)*<sup>[4]</sup>.

A variety of technical options are available for the realization of the ultra-low emissions of dust, SO<sub>2</sub> and NO<sub>x</sub>, and the principle technical route is shown in Figure 7-1. In practical engineering application, it is necessary to



consider the synergy of different pollutant control devices; follow the principle of “adapt to coal characteristics, boiler types and local conditions; make overall planning and strive for sustainable development”; choose efficient control technologies that are economical, mature, stable and easy to maintain and have synergetic removal effects and good performance; and determine specific technology routes to ensure that dust, SO<sub>2</sub> and NO<sub>x</sub> can meet the ultra-low emission requirement.

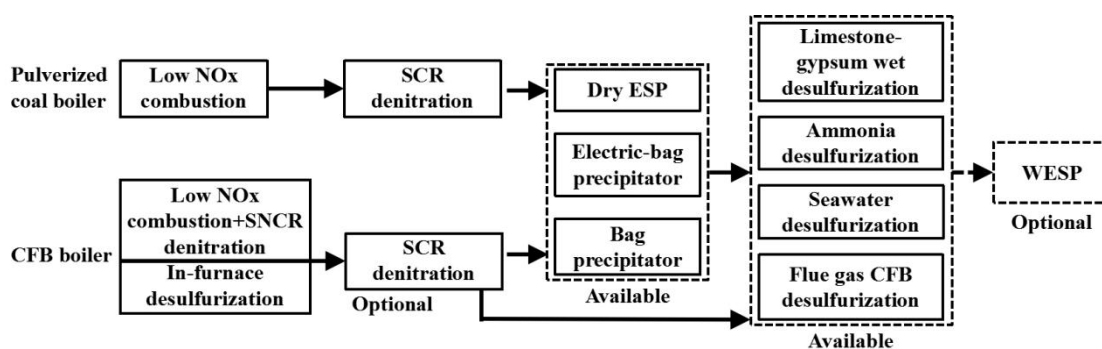

**Figure 7-1 Ultra-low emission technical route of coal-fired plants**

### 7.2.1 Technical route for ultra-low dust emission

(1) Coal-fired power plants should adopt both the primary and secondary dedusting methods to achieve ultra-low dust emission.

Primary dedusting measure refers to efficient dust removal before wet flue gas desulfurization (WFGD) to achieve ultra-low dust emission. The dedusting technologies mainly include electrostatic precipitators (ESP), electric-bag precipitation and bag precipitation. ESP can achieve an efficiency of no lower than 99.85% through the adoption of efficient power supply, advanced ash removal methods and low-temperature ESP

(LLT-ESP), while the other two technologies can achieve an efficiency of no lower than 99.9%.

Secondary dedusting measure refers to synergistic dedusting in the WFGD process and a further removal of dust by WESP to achieve ultra-low dust emission. The limestone-gypsum WFGD-based integrated tower technology, equipped with an efficient demister or a wet electrostatic precipitators (WESP) installed in the desulfurization system, can achieve a synergistic efficiency of no lower than 70%, while a WESP installed after the WFGD helps achieve an efficiency of no lower than 70% stably.

(2) In practical engineering application, coal-fired power plants should consider the characteristics, applicability, economics, maturity of various technologies, secondary pollution, etc. when choosing the ultra-low dedusting technical routes. (See Table 7-2 for details)

**Table 7-2 Ultra-low dust emission technology** <sup>[3]</sup>

Boiler type (combustion mode)	Unit capacity (MW)	Dust concentration of inlet flue gas (mg/m <sup>3</sup> )	Primary dedusting			Secondary dedusting	
			ESP (Efficiency $\geq 99.85\%$ )	Electric-bag precipitation (Efficiency $\geq 99.9\%$ )	Bag precipitation (Efficiency $\geq 99.9\%$ )	WESP (Efficiency $\geq 70\%$ )	WFGD synergy (Efficiency $\geq 70\%$ )
Pulverized coal boiler (tangentially firing, wall firing)	$\leq 200$	$\geq 30000$	★	★★★★	★★★★	★★★★	★
		20000~30000	★★	★★	★★	★★	★★
		$\leq 20000$	★★★★	★	★	★	★★★★
	300	$\geq 30000$	★	★★★★	★★	★★★★	★
		20000~30000	★★	★★	★	★★	★★
		$\leq 20000$	★★★★	★	★	★	★★★★
	$\geq 600$	$\geq 30000$	★	★★★★	★	★★★★	★

		20000~ 30000	★★	★★	★	★★	★★
		≤20000	★★★★	★	★	★	★★★★
Pulverized coal boiler (W-flame firing)		≥30000	★	★★★★	★★	★★★★	★
		20000~ 30000	★★	★★★★	★	★★	★★
		≤20000	★★★★	★★	★	★	★★★★
CFB boiler			★	★★★★	★★	★★★★	★

Notes: (1) The properties of coal and ash should be firstly considered to judge whether ESP is suitable for the primary dedusting process; if not, an electric-bag precipitator or a bag precipitator is preferred.

(2) The ultra-clean electric-bag precipitator is preferred for ultra-low emission (a dust concentration of less than 10mg/m<sup>3</sup> or 5mg/m<sup>3</sup>) when only primary dedusting is applied.

(3) When the outlet dust concentration of primary dedusting process is between 30mg/m<sup>3</sup> and 50mg/m<sup>3</sup>, WESP is more suitable for the secondary dedusting; when the figure is between 20mg/m<sup>3</sup> and 30mg/m<sup>3</sup>, WFGD with synergistic dedusting or WESP is more suitable; when the figure is less than 20mg/m<sup>3</sup>, WFGD with synergistic dedusting is more suitable.

(4) In the table, ★ indicates the level of recommendation: more ★ means greater effects and preference.

## 7.2.2 Technical route for ultra-low SO<sub>2</sub> emission

(1) The limestone-gypsum WFGD technology is applicable to all types of coal-fired power plants. To achieve ultra-low emission stably, different desulfurization processes are applied for different inlet SO<sub>2</sub> concentrations. Meanwhile, the specific process should be chosen based on both its economics and maturity (See Table 7-3 for details).

**Table 7-3 Ultra-low SO<sub>2</sub> emission by limestone-gypsum WFGD technology [3]**

Inlet SO <sub>2</sub> concentration (mg/m <sup>3</sup> )	Desulfurization process and efficiency					
	≤1000	Effect raising of hollow spraying tower	97%			
≤2000	Double tray, boiling bubble	98.5%				
≤3000	Turbulence coupling, double tray, turbulent tube grid		99%			
≤6000	Dual pH value of single spraying tower, turbulence coupling, turbulent tube grid			99.5%		

≤10000	Dual pH value of hollow spraying tower, turbulence coupling	99.7%
--------	---	-------

Notes: (1) To achieve ultra-low emission stably, the desulfurization efficiency is calculated assuming 30mg/m<sup>3</sup> of SO<sub>2</sub> concentration at the outlet of desulfurization tower.

(2) The technology applicable to high inlet SO<sub>2</sub> concentration is also suitable for low inlet SO<sub>2</sub> concentration.

(2) In water-deficient areas where the quality of absorbents is guaranteed, CFB desulfurization technology can be applied for coal-fired power units of 300MW and below with an inlet SO<sub>2</sub> concentration of no more than 1500mg/m<sup>3</sup>. When the in-furnace desulfurization efficiency of CFB boiler is considered, flue gas CFB desulfurization can be used for CFB units of 300MW and below that use coal containing medium sulfur. When seawater diffusion conditions are good and the requirement of environmental function zoning in the nearshore sea area is met, coastal power plants with an inlet SO<sub>2</sub> concentration of no more than 2000mg/m<sup>3</sup> can use the efficient seawater desulfurization technology. With stable ammonia supply, short transportation distance and an insensitive environment, ammonia desulfurization can be applied to coal-fired power units of 300MW and below. (See Table 7-4 for details)

**Table 7-4 Ultra-low SO<sub>2</sub> emission by flue gas CFB desulfurization, seawater desulfurization and ammonia desulfurization technologies** <sup>[3]</sup>

Inlet SO <sub>2</sub> concentration (mg/m <sup>3</sup> )	Area	Single unit capacity (MW)	Ultra-low emission technology
≤1500	Especially suitable for water-deficient areas	≤300	Flue gas CFB desulfurization
≤2000	Coastal areas	300~1000	Seawater desulfurization

$\leq 10000$	Stable ammonia source within a 200km radius of the power plant	$\leq 300$	Ammonia desulfurization
--------------	--	------------	----------------------------

### 7.2.3 Technical route for ultra-low NO<sub>x</sub> emission

(1) In-furnace low NO<sub>x</sub> combustion is the preferred technology for NO<sub>x</sub> control. The NO<sub>x</sub> concentration should be reduced as much as possible at the boiler's outlet while ensuring the boiler's efficiency and safety.

(2) For pulverized coal boilers, burner retrofit and in-furnace combustion condition optimization should be carried out to ensure that the NO<sub>x</sub> concentration is lower than 550mg/m<sup>3</sup> at the boiler's outlet. When SCR denitration technology is applied after in-furnace combustion, the stable and efficient operation of denitration device should be ensured by selecting the number of catalyst layers, precise ammonia injection and uniform flow distribution to achieve ultra-low NO<sub>x</sub> emission.

(3) The combustion method of CFB boilers should be adjusted to ensure that the concentration of produced NO<sub>x</sub> is less than 200mg/m<sup>3</sup>, while a SNCR denitration device should be further installed to achieve ultra-low NO<sub>x</sub> emission; SNCR-SCR denitration technology can be adopted if necessary.

(4) As for the W-type flame boilers with anthracite as fuel, ultra-low NO<sub>x</sub> emission is still difficult to be realized even adopting the low NO<sub>x</sub> combustion technology and SCR denitration technology.

(5) The ultra-low NO<sub>x</sub> emission technical routes for various boiler types are shown in Table 7-5.

**Table 7-5 Ultra-low NO<sub>x</sub> emission technologies** <sup>[3]</sup>

Type of boiler	Inlet concentration (mg/m <sup>3</sup> )	Denitration efficiency (%)	Layers of SCR catalyst
Pulverized coal boiler (tangentially firing, wall firing)	<200	80	2+1
	200~350	80~86	3+1
	350~550	86~91	
CFB boiler		60~80	SNCR (+SCR)

Note: The “n” in “n+1” represents the layers of catalysts and “1” represents the installment space reserved for alternative catalysts.

### 7.3 Policy Drivers

To control the flue gas pollutant emission of coal-fired power plants, the Chinese government has successively issued a series of policies, regulations and standards, among which the *Emission Standard of Air Pollutants for Thermal Power Plants* (issued in 1991 and revised in 1996, 2003 and 2011 respectively) has guided the development and application of air pollutant control technologies, and promoted the reduction and gross control of air pollutants in coal-fired power plants.

In June 2014, China’s State Council issued the *Action Plan for Energy Development Strategy (2014~2020)*, which further improved the thresholds of coal-fired power units by requiring that the air pollutant emission of newly-built coal-fired power units approach the emission standards of gas-fired power units. In September 2014, the National

Development and Reform Commission (NDRC), Ministry of Ecology and Environment (MEE) (formerly Ministry of Environmental Protection, MEP) and National Energy Administration (NEA) issued the *Action Plan for the Upgrading and Retrofit of Coal-Fired Power Plants for Energy Conservation and Emission Reduction (2014-2020)*, which firstly set the ultra-low emission requirements for coal-fired power plants from the national level. In March 2015, China further proposed to fully implement the retrofit of coal-fired power plants for ultra-low emission and energy conservation, and set the deadline of full implementation by 2020 in December 2015. In the same month, the Chinese government issued relevant plans and notifications to support ultra-low emission, among which the *Work Plan for Fully Implementing the Retrofit of Coal-Fired Power Plants for Ultra-Low Emission and Energy Conservation* specified the requirements for ultra-low emission, and the *Notification on Issues Related to Implementing Price Supportive Policy for Ultra-Low Emission of Coal-Fired Power Plants* stipulated a subsidy of 0.01 yuan and 0.005 yuan per kWh for units operating on the grid before and after January 1, 2016 respectively. In November 2016, China's State Council issued the *Implementation Plan for the Permit System for Controlling Pollutants Emission*, which introduced an emission permit system to guarantee the up-to-standard emission and gross control of air pollutants for coal-fired power plants.

From 2014 to 2015, the promulgation of national policies and regulations quickly activated the demand of coal-fired power plants for ultra-low emission retrofit. Accordingly, local governments successively issued plans and schemes to support such retrofit. Developed areas represented by Beijing-Tianjin-Hebei, the Yangtze River Delta and the Pearl River Delta, implemented more stringent requirements for coal-fired power plants. Meanwhile, relevant incentives and punishment policies were introduced across China, which mobilized coal-fired power enterprises and advanced ultra-low emission retrofit.

#### **7.4 Achievements in Ultra-Low Emission Implementation**

According to the statistics from NEA, by the end of the third quarter in 2018, more than 700GW of coal-fired power plants in China completed the ultra-low emission retrofit, and overfulfilled the total target of 580GW ahead of schedule. Together with newly-built ultra-low emission units, more than 750GW of coal-fired power units in China reached ultra-low emission limits, accounting for 75% of the total, thus completing the ultra-low emission task set out in the Thirteenth Five-Year Plan (2016-2020) two years in advance.

In terms of major power generation enterprises, by the end of 2018, a total of 343 (or 160GW) coal-fired power units in China Energy achieved ultra-low emission, accounting for 91% of its total installed thermal power



capacity; a total of 281 (or 112GW) units in China Huaneng Group achieved ultra-low emission, accounting for 94% of its total installed thermal power; in China Huadian Corporation, 86.5% of coal-fired power units achieved ultra-low emission, and its coal-fired power units in central China basically completed the ultra-low emission retrofit; in China Datang Corporation, 224 (92.475GW) coal-fired power units achieved ultra-low emission, accounting for 94.7% of its total installed thermal power .

## **7.5 Significance of ultra-low emission**

(1) Ultra-low emission is a key measure to promote clean coal utilization.

Guided and supported by relevant laws, regulations and policies on energy conservation and emission reduction, coal-fired power plants have greatly reduced their emissions of dust, SO<sub>2</sub> and NO<sub>x</sub> through the development of advanced coal-fired power generation technologies and advanced flue gas control technologies for ultra-low emission (Figure 7-2). The unit cost for coal-fired power units has only increased by 0.01 to 0.02 yuan after the ultra-low emission retrofit, and the total unit cost is only about half of that for gas turbine units, which makes coal-fired power more competitive.

According to the statistics of CEC, as the installed capacity of coal-fired power increased by 30% from 2012 to 2017 in China, the emissions of dust, SO<sub>2</sub> and NO<sub>x</sub> decreased from 1.51Mt, 8.83Mt and 9.48Mt to 0.26Mt, 1.2Mt

and 1.14Mt respectively <sup>[5]</sup>, which represented a reduction of 83%, 86% and 88% respectively. In 2018, the emissions of dust, SO<sub>2</sub> and NO<sub>x</sub> by coal-fired power units accounted for 3.3%, 13.7% and 9.1% of the national total respectively. Therefore, coal-fired power is no longer the main contributor to environmental pollution in China.

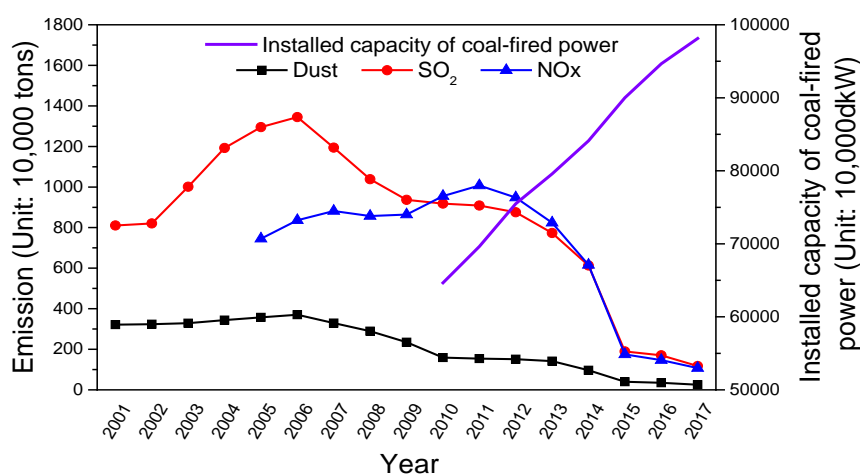

**Figure 7-2 Installed capacity and air pollutants emission of coal-fired power in China from 2001 to 2017**

(2) Ultra-low emission in coal-fired power plants motivates technological upgrading of environmental protection equipment in power industry.

The ultra-low emission of coal-fired power plants has made great contribution to the establishment of the world’s largest clean coal-power supply system in China, and promoted technological upgrading for environmental protection in China’s power industry. A series of advanced environment protection technologies and equipment with independent intellectual property rights have been developed, thus making China’s environmental protection technologies among the top in the world; some

technologies and equipment have been exported and received international acclaim, which provide mature, efficient and low-cost technologies for the global emission reduction of air pollutants.

## **7.6 Cases of project construction and operation**

### **7.6.1 Zhejiang Zhoushan Power Plant**

Zhejiang Zhoushan Power Plant has a total installed capacity of 910MW, and its No.1 (125MW), No.2 (135MW), No.3 (300MW), No.4 (350MW) coal-fired power units were put into commercial operation in November 1997, March 2004, October 2010 and June 2014 respectively (Figure 7-3). Unit 4 is the first newly-built demonstration project for the ultra-low emission of coal-fired power units in China.

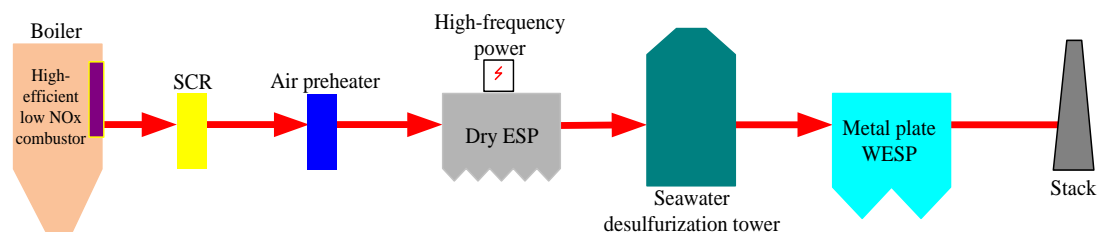

**Figure 7-3 Panorama of Zhejiang Zhoushan Power Plant**

#### **(1) Technical route**

Unit 4 adopts an ultra-low emission technical route of “in-furnace low  $\text{NO}_x$  combustion + high-efficient SCR denitration + dry ESP + seawater

desulfurization with synergistic dedusting + WESP”, as shown in Figure 7-4. The control objectives of air pollutants are designed as: dust $\leq$ 5mg/m<sup>3</sup>, SO<sub>2</sub> $\leq$ 35mg/m<sup>3</sup>, NO<sub>x</sub> $\leq$ 50mg/m<sup>3</sup>.



**Figure 7-4 Implementation route of ultra-low emission technology in Unit 4 of Zhoushan Power Plant**

1) Dust emission control measures: 4 conventional ESPs and 1 rotary electrode ESP are installed and the high-frequency power is retrofitted, which controls the outlet dust concentration within 30mg/m<sup>3</sup>; a WESP is installed at the desulfurization tower’s outlet to control the outlet dust concentration within 5mg/m<sup>3</sup>.

2) SO<sub>2</sub> emission control measures: Based on the geographical advantages, the seawater desulfurization technology is adopted in Unit 4, which makes it the first seawater desulphurization project appraised by China Environmental Impact Assessment of MEE with a desulfurization efficiency of no less than 98%. Furthermore, the seawater desulfurization technology guarantees that the outlet SO<sub>2</sub> concentration is within 35mg/m<sup>3</sup>.

3) NO<sub>x</sub> emission control measures: The efficient low NO<sub>x</sub> combustor retrofit controls the outlet NO<sub>x</sub> concentration within 200mg/m<sup>3</sup> (under whole operating condition) and 160mg/m<sup>3</sup> (when 75~100% loaded)

respectively. With a SCR denitration device installed, the denitration efficiency can reach 80%, and the NO<sub>x</sub> emission concentration is controlled within 50mg/m<sup>3</sup>.

## (2) Implementation Results

The monitoring report issued by Zhejiang Environmental Monitoring Center shows that the emission concentrations of dust, SO<sub>2</sub> and NO<sub>x</sub> of Unit 4 are 2.46mg/m<sup>3</sup>, 2.76mg/m<sup>3</sup> and 19.8mg/m<sup>3</sup> respectively under 100% loading conditions after the ultra-low emission technical route is adopted.

### 7.6.2 Hebei Sanhe Power Plant

Hebei Sanhe Power Plant is located in Yanjiao Town, Sanhe City, Hebei Province, only 37.5 kilometers away from Tiananmen Square in Beijing. The power plant is a crucial power support for Eastern Beijing and an important heat source for residents in Beijing and Hebei.

The total installed capacity of Hebei Sanhe Power Plant is 1300MW. In Phase I, No.1 350MW and No.2 350MW of coal-fired power units were put into commercial operation in December 1999 and April 2000 respectively; in Phase II, No.3 300MW and No.4 300MW of coal-fired power units were put into commercial operation in August and November, 2007 respectively (Figure 7-5). In 2018, the power plant supplied more than 10MGJ of heat for Beijing and Hebei, with a 287.19g/kWh coal

consumption for power supply.



**Figure 7-5 Panorama of Hebei Sanhe Power Plant**

Unit 1 completed its ultra-low emission retrofit in July 2014, and Unit 2, Unit 4 and Unit 3 in November 2014, June 2015 and November 2015 respectively, thus making the plant the first coal-fired power plant that had achieved ultra-low emission in the Beijing-Tianjin-Hebei region. In October 2014, NEA honored Sanhe Power Plant as a National Coal Power Paragon Station for its success in energy conservation and emission reduction.

#### (1) Technical route

Based on the four units' operation status, Sanhe power plant has developed different technical routes for their ultra-low emission retrofit. Through the combined application of different pollution control technologies and the integrated system optimization, the four units all achieved ultra-low

emission and operated economically and efficiently, showcasing the feasibility, advancement and demonstrative role of the technical route.

### 1) Technical route for ultra-low emission of Unit 1

Unit 1 firstly carried out the ultra-low emission retrofit, and its technological implementation route is shown in Figure 7-6. The main retrofit measures include: adopting an M-PM low NO<sub>x</sub> combustor; installing an SCR denitration device and a low-temperature economizer; carrying out high-frequency power retrofit of ESP, the integration retrofit of induced draft fan and blower fan, and desulfurization retrofit for capacity and effect raising; removing the gas-gas heater; installing a flexible plate WESP to change the exhausting way of flue gas. The control objectives of air pollutants are designed as: dust ≤ 5mg/m<sup>3</sup>, SO<sub>2</sub> ≤ 35mg/m<sup>3</sup>, NO<sub>x</sub> ≤ 50mg/m<sup>3</sup>.

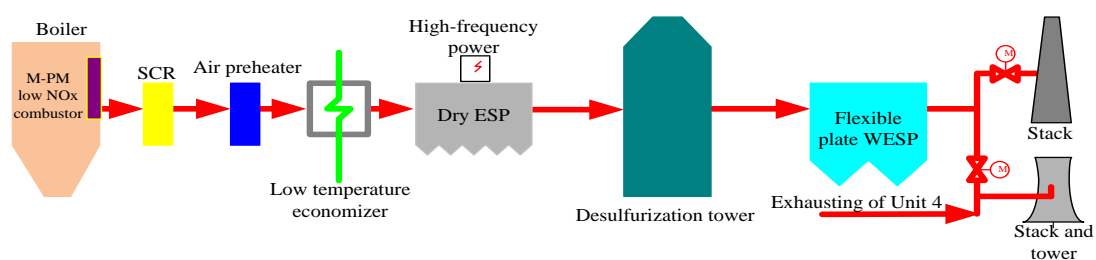
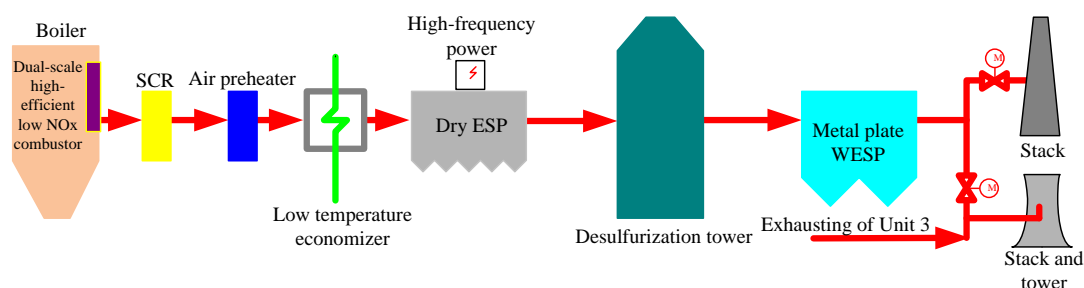

**Figure 7-6 Implementation route of ultra-low emission technology in Unit 1 of Sanhe Power Plant**

### 2) Technical route for ultra-low emission of Unit 2

Based on the successful implementation of Unit 1, Unit 2 made further exploration and adopted a dual-scale, efficient, low NO<sub>x</sub> combustor and a

metal plate WESP. The technical route is shown in Figure 7-7. After the ultra-low emission, the dust emission concentration of Unit 2 is further reduced. The overall control objectives are: dust  $\leq 3\text{mg}/\text{m}^3$ ,  $\text{SO}_2 \leq 35\text{mg}/\text{m}^3$ ,  $\text{NO}_x \leq 50\text{mg}/\text{m}^3$ .

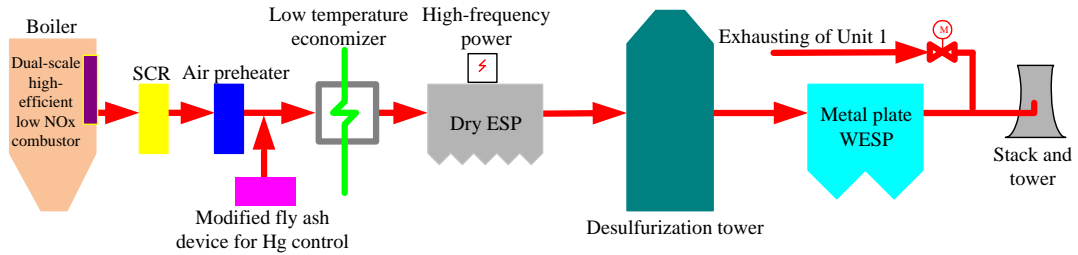

**Figure 7-7 Implementation route of ultra-low emission technology in Unit 2 of Sanhe Power Plant**

### 3) Technical route for ultra-low emission of No. 4 Unit

The retrofit of Unit 4 set more stringent targets for air pollutant control than those of Unit 1 and Unit 2. Besides, Unit 4 adopted a modified fly ash-based demercuration technology with its own intellectual property rights, which was China's first Hg control demonstration project. The technical route is shown in Figure 7-8. The main retrofits include: installing a dual-scale, efficient, low  $\text{NO}_x$  combustor, mercury control device by modified fly ash, and low-temperature economizer; carrying out ESP high-frequency power retrofit; installing an integrated tube bundle device for dust and mist removal and a WESP. The overall control objectives are: dust  $\leq 1\text{mg}/\text{m}^3$ ,  $\text{SO}_2 \leq 15\text{mg}/\text{m}^3$ ,  $\text{NO}_x \leq 25\text{ mg}/\text{m}^3$ .

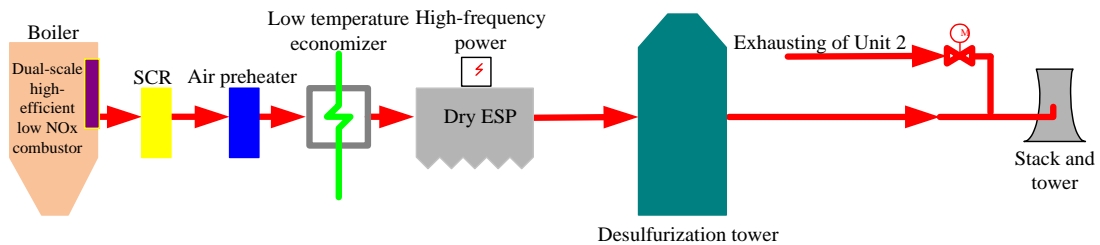



**Figure 7-8 Technical route of ultra-low emission technology in Unit 4 of Sanhe Power Plant**

4) Technical route for ultra-low emission of Unit 3

The technical route for the ultra-low emission of Unit 3 is different from those of Unit 1, Unit 2 and Unit 4, as shown in Figure 7-9. Unit 3 is not equipped with a WESP, and only its integrated desulfurization and dedusting technology is retrofitted to strengthen the synergistic dedusting effect of desulfurization system. The overall control objectives are: dust  $\leq 3\text{mg}/\text{m}^3$ ,  $\text{SO}_2 \leq 15\text{mg}/\text{m}^3$ ,  $\text{NO}_x \leq 25\text{mg}/\text{m}^3$ .



**Figure 7-9 Implementation route of ultra-low emission technology in Unit 3 of Sanhe Power Plant**

(2) Implementation Results

The emission concentrations of the four units in Sanhe Power Plant before and after the ultra-low emission retrofit are shown in Table 7-6.

**Table 7-6 Pollutants emission concentrations of Units 1 to 4 before and after the retrofit for ultra-low emission in Sanhe Power Plant**

		Dust (mg/m <sup>3</sup> )	SO <sub>2</sub> (mg/m <sup>3</sup> )	NO <sub>x</sub> (mg/m <sup>3</sup> )
Unit 1	Before	15.3	34	484
	After	5	9	35
Unit 2	Before	15.1	33.2	256.6
	After	3	10	25
Unit 3	Before	17.1	19.8	85.3
	After	2	12	22
Unit 4	Before	15.9	31.9	80.3
	After	0.23	5.9	20

The monitored emission concentrations of dust, SO<sub>2</sub> and NO<sub>x</sub> were 5mg/m<sup>3</sup>, 9mg/m<sup>3</sup> and 35mg/m<sup>3</sup> respectively after the retrofit of Unit 1, which met and exceeded the emission limits of gas turbine units, thus making the unit NEA's first completed demonstration project among all environmental retrofit projects for coal-fired power plants in 2014. Building on the successful implementation of Unit 1, the dust, SO<sub>2</sub> and NO<sub>x</sub> emissions of Unit 2 was reduced to 3mg/m<sup>3</sup>, 10mg/m<sup>3</sup> and 25mg/m<sup>3</sup> respectively; the dust emission of Unit 4 after the retrofit was only 0.23mg/m<sup>3</sup>, and its SO<sub>2</sub> and NO<sub>x</sub> emissions were 5.9mg/m<sup>3</sup> and 20mg/m<sup>3</sup> respectively. After the adoption of different technical schemes and WESPs with different performances, the emission of dust decreased from 5mg/m<sup>3</sup> to 3mg/m<sup>3</sup> and then to 1mg/m<sup>3</sup> for Unit 1, Unit 2 and Unit 4. Through the optimization of integrated desulfurization and dedusting technology, Unit 3 achieved a dust emission of 2mg/m<sup>3</sup> without the installation of WESP, and its SO<sub>2</sub> and NO<sub>x</sub> emissions were reduced to 12mg/m<sup>3</sup> and 22mg/m<sup>3</sup> respectively.

After the successful application of modified fly ash-based Hg control

technology in Unit 4, another engineering demonstration has been carried out in a 1000MW coal-fired power unit of Jiangsu Xuzhou Power Plant. The Hg emission concentration is as low as  $0.29\mu\text{g}/\text{m}^3$  and the comprehensive Hg control efficiency is higher than 94%, which is only 1% of the Hg emission limit set by China's *Emission Standard of Air Pollutants for Thermal Power Plants (GB13223-2011)*. Meanwhile, the deep removal of heavy metals such as arsenic, selenium, lead, cadmium and antimony has also been achieved with a comprehensive efficiency of more than 90%. In addition, the cost of modified fly ash-based Hg control technology is only 10-15% of that by the activated carbon-based Hg control technology.

### 7.6.3 Economics of ultra-low emission

The cost analysis of the ultra-low emission retrofit of Hebei Sanhe Power Plant's four coal-fired power units shows that, assuming an annual system operation of 5,000 hours for 15 years, the cost of the four units after the retrofit only increases by 0.09 to 0.13 cent (USD) per kWh, among which the cost of Unit 1, Unit 2 and Unit 4 increases by 0.1 cent, 0.11 cent and 0.13 cent per kWh respectively, while the cost of Unit 3 increases by 0.09 cents per kWh due to the reduced investment in WESPs and operation costs. The results show that the implementation of ultra-low emission retrofit may increase the operation costs of power generation enterprises, but the power generation cost after such retrofit is still significantly lower than that of gas-fired power generation.

## References

---

[1] Ministry of Environmental Protection, General Administration of Quality Supervision, Inspection and Quarantine of China. Emission Standard of Air Pollutants for Thermal Power Plants (GB 13223-2011)[S]. China Environmental Science Press, Beijing, 2011.

[2] China Electricity Council. Annual Development Report of China Power Industry 2013[M]. China market press, Beijing, 2013.

[3] Ministry of Environmental Protection. Guideline on Available Technologies of Pollution Prevention and Control for Thermal Power Plants (HJ 2301-2017)[M]. China Environmental Science Press, Beijing, 2017.

[4] Ministry of Ecology and Environment. Technical Specifications for Flue Gas Treatment Engineering of Coal-Fired Power Plants Under Ultra-Low Emission (HJ 2053-2018)[S]. China Environmental Science Press, Beijing, 2018.

[5] China Electricity Council. Annual Development Report of China Power Industry 2018[M]. China market press, Beijing, 2018.

## Chapter VIII CCS/CCUS Technology in China

In recent years, Climate change and greenhouse gas (GHG) emission become hot issues of global concern. From the *1992 United Nations Framework Convention on Climate Change* to *1997 Kyoto Protocol* to *2016 Paris Agreement*, the international community gradually reaches a consensus on tackling climate change and confirming the globally-agreed target of limiting future temperature increases.

Among diverse GHG emission reduction approaches, such as pressing ahead with energy conservation, improving energy efficiency, developing renewable energy, and increasing carbon sink, carbon capture, utilization and storage (CCS/CCUS) technology is an essential technical option in the future. The *Fifth Assessment Report (AR5)* of IPCC (2014) identifies CCUS as being critical to achieving more ambitious climate targets: many models could not achieve atmospheric concentration levels of about 450 ppm CO<sub>2</sub> by 2100 under limited availability of key technologies, such as bioenergy, CCS and their combination; without CCS, the cost of achieving atmospheric concentrations in the range of 430-480 ppm CO<sub>2</sub> would be almost doubled.<sup>[1]</sup> IEA points out that “to achieve the goal of limiting the global temperature increase below 2°C by the end of this century, the global CCS deployment scale needs to reach about 4 billion tons by 2040, contributing 14% of carbon reduction.”<sup>[2]</sup>

The Chinese government attaches great importance to and actively respond to climate change, successively formulating and issuing major strategic documents such as the *National Plan for Tackling Climate Change 2014-*

*2020, The National Strategy for Climate Change Adaptation, and the Work Plan for Controlling Greenhouse Gas Emissions During the 13th Five-Year Plan Period.* These documents clearly state that China will accelerate the development of non-fossil energy, optimize the use of fossil energy, speed up R&D of low-carbon technologies, and promote the pilot demonstration of CCUS [3-5].

Based on China's energy resource endowment dominated by coal, CCS/CCUS, as a technology that can realize large-scale low-carbon utilization of fossil energy, can ensure a smooth transition of China's energy mix, from fossil energy dominance to renewable energy dominance. The Chinese government has invested a large amount of research funds to systematically deploy CCS/CCUS basic theoretical research, R&D of key technologies, and industrial demonstration, etc., in order to reduce the energy consumption and cost of CCUS, extend CO<sub>2</sub> resource utilization, and thereby improve the sustainability and economic benefits of CCS/CCUS technology.

## **8.1 CCS/CCUS R&D in China**

Since 2006, China has funded a series of CCUS-related research on developing strategy and fundamental theories as well as critical technologies, through the National Basic Research Program (973 Program), National High-tech R&D Program (863 Program) and National Science and Technology Support Program. And also, China actively carried out international cooperation research with the European Union, Australia, ADB and other economies and international institutions, thereby

effectively promoting China's CCUS technology development.

### 8.1.1 CO<sub>2</sub> Capture R&D

In power generation, there are three main approaches to capturing CO<sub>2</sub>. They differ based on the power generation cycle: pre-combustion, post-combustion and oxy-combustion capture (Figure 8-1) [6]

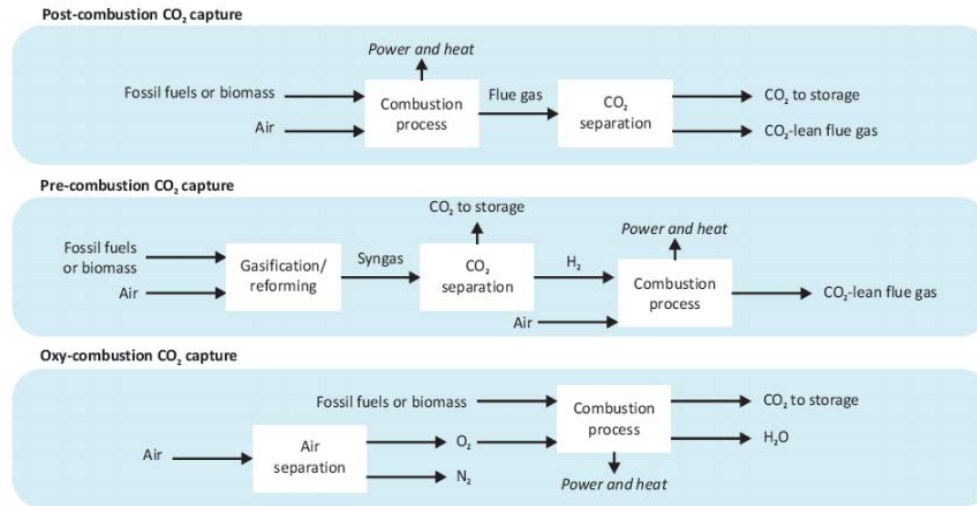

**Fig. 8-1 CO<sub>2</sub> Capture Technologies**

Source: IEA, Energy Technology Perspectives 2012

After years of R&D, China has made various remarkable progresses in CO<sub>2</sub> capture. China's first IGCC power station was successfully commissioned in 2012; the 35MWth oxy-fuel combustion industrial demonstration system was completed in 2014; types of new commercial CO<sub>2</sub> sorbents have been developed for high-efficiency and low-cost CO<sub>2</sub> separation and for diverse technical routes.

#### (1) Pre-Combustion Capture-IGCC Technology

Pre-combustion capture refers to the separation of carbon from fuel before combustion, which is mainly applicable to integrated gasification combined cycle (IGCC).

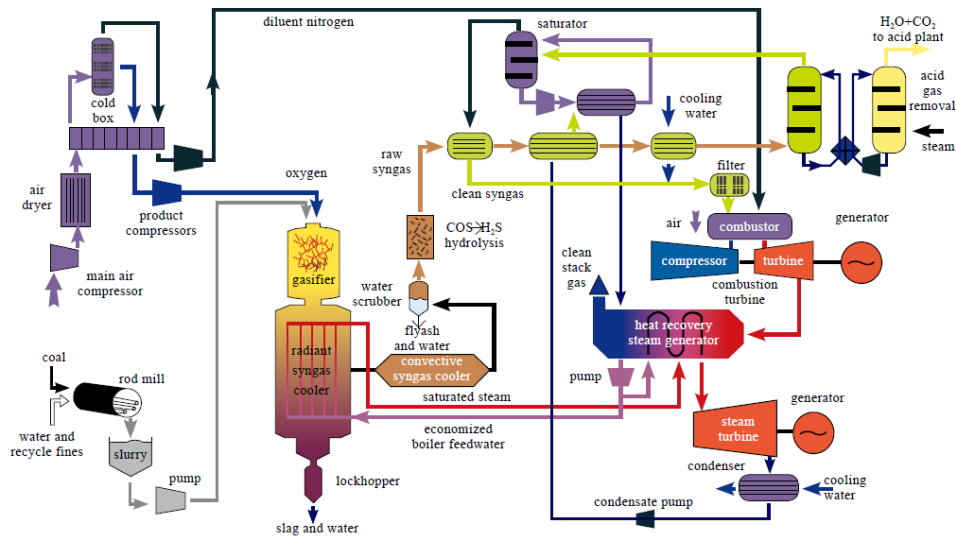

**Fig. 8-2 Schematic Diagram of IGCC System**

In an IGCC plant, coal gasification, syngas purification and gas-steam combined cycle power generation are systematically integrated together, realizing efficient and clean utilization of coal (Figure 8-2). IGCC has one major advantage of high syngas pressure and high CO<sub>2</sub> concentration after water-gas shift reaction, hence easy carbon capture. Its pollutants emission is as low as only 1/3 of that of SC/USC units with the same capacity. However, IGCC technology is still at an early stage of commercial demonstration: some key technologies are still not mature, while the capital investment and the cost of power generation are relatively high, thus IGCC cannot compete with USC in mass production at present.

With the support and promotion of the NDRC, MOST and other government departments, China's research institutions and enterprises have carried out a few fundamental researches on key equipment of IGCC system:

- 1) East China University of Science and Technology, Tsinghua



University, Xi'an Thermal Power Research Institute Co., Ltd and other institutions have cooperated with enterprises to develop various types of gasifier technologies, which have been commercialized in China and started to be exported overseas.

- 2) Institutions such as Tsinghua University jointly established the National Engineering Research Center for Gas Turbine and Gasification Combined Cycle to independently develop and design the gas turbine prototype. Through the relentless efforts of nearly ten years, CGT-60F, as a demonstrator for Class F 300MW gas turbine technology, has been successfully developed with full independent intellectual property rights.
- 3) Funded by the 863 Program, Shandong Yanzhou Mining Group has cooperated with the Institute of Engineering Thermophysics, Chinese Academy of Sciences and other institutions to build a polygeneration demonstration plant of methanol and power production, which was commissioned in April 2006, with the capacity of 600,000 tons of acetic acid, 300,000 tons of methanol, 200,000 tons of ethyl acetate and 80MW of electricity.
- 4) With the support of the former Ministry of Electric Power, as well as 863 Program under the “Tenth Five-Year Plan” and the “Eleventh Five-Year Plan”, Huaneng Group proposed the “Greengen” plan. Under this plan, the Huaneng Greengen Project, China’s first IGCC power plant merely for power

generation was commissioned in December 2012.

## (2) Oxy-Combustion Technology

Oxy-combustion process is illustrated in Figure 8-3: air separation unit or oxygen generation technology is adopted to remove nitrogen from the air; oxygen instead of air is employed for fossil fuel combustion; the flue gas obtained has high concentration of CO<sub>2</sub> gas. However, the cost of oxygen generation by air separation is relatively high.

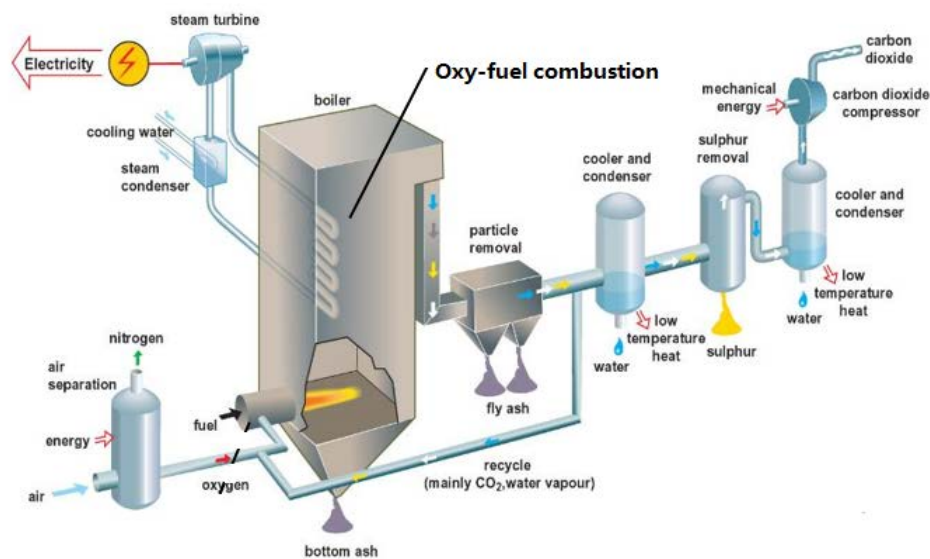

**Figure 8-3 Schematic Diagram of Oxy-combustion Process**

With the support of National Science and Technology Support Program, 973 Program, 863 Program and key projects under the National Natural Science Foundation, the State Key Laboratory of Coal Combustion, Huazhong University of Science and Technology has successively built a 400KWth oxy-combustion comprehensive testbed, a 3MWth oxy-combustion full process system and a 35MWth industrial demonstration system for oxy-combustion power generation, and has drawn up a systematic plan together with roadmap for the development of oxy-combustion carbon capture technology (0.4MWth → 3MWth → 35MWth

→ 200MWe) <sup>[7]</sup>.

At present, the 35MWth industrial demonstration system for oxy-combustion power generation has been completed by the end of 2014; the pre-feasibility study report for the 200MW oxy-combustion power generation industrial demonstration project was completed in the first half of 2015.

### (3) Post-combustion Capture Technology

Post-combustion capture and separation mainly refers to the separation of CO<sub>2</sub> and N<sub>2</sub> from the flue gas after combustion. Among various separation approaches, chemical solvent absorption has higher capture efficiency and selectivity, and lower energy consumption and collection cost. In addition, there are physical absorption, membrane separation, etc.

Nanjing Chemical Research Institute under Sinopec, Huaneng Group, Tsinghua University, Zhejiang University, Process Research Institute of Chinese Academy of Sciences and other institutions have carried out massive research and made important achievements in new composite amine absorbent, ionic liquid, and new type of ammonia absorbent. Compared with the existing industrial MEA technology, energy consumption of CO<sub>2</sub> capture has decreased significantly. <sup>[8]</sup>

China has independently developed new types of composite amine absorbent with high recycling efficiency, high absorption capacity and low regeneration energy consumption, which have been applied in the 3000-ton/year CO<sub>2</sub> capture device of Beijing Thermal Power Plant and 120,000-ton/year CO<sub>2</sub> capture device of Shanghai Shidongkou NO.2 Power Plant.

Thick-slurry CO<sub>2</sub> absorbent and phase transition extraction CO<sub>2</sub> absorbent are under development.

### 8.1.2 R&D of CO<sub>2</sub> Storage Technology

CO<sub>2</sub> storage technology involves injecting CO<sub>2</sub> into underground Saline aquifer or depleted oil (gas) reservoir to permanently store it (Figure 8-4). At present, the main storage methods include saline storage, CO<sub>2</sub>-EOR, CO<sub>2</sub>-ECBM, etc.

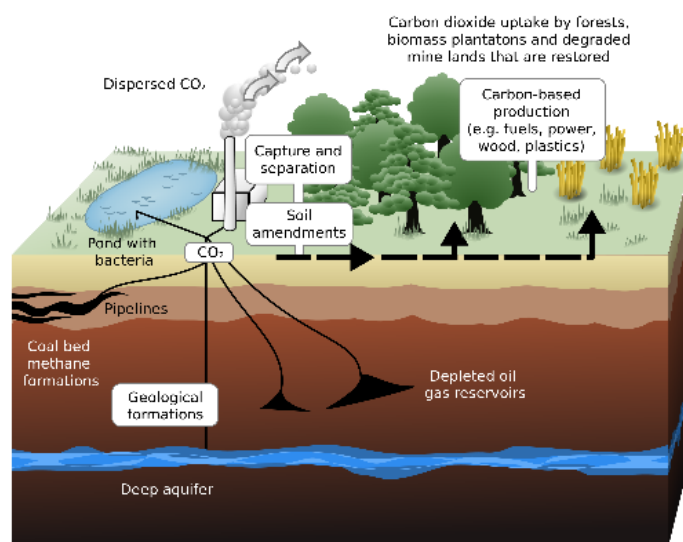

**Figure 8-4 Schematic Diagram of CO<sub>2</sub> Storage and Utilization**

In 2009, the Ministry of Land and Resources incorporated the investigation and evaluation of CO<sub>2</sub> geological storage potential into the *Implementation Plan of Geological and Mineral Resources Guarantee Project (2010-2020)*. The evaluation results show that the main type of CO<sub>2</sub> geological storage in China is deep saline aquifer, of which the eastern basin has the greatest potential for CO<sub>2</sub> geological storage. Tsinghua University, Chinese Academy of Sciences and other institutions have conducted research on the source and sink characteristics of CO<sub>2</sub> in China and the source-sink

matching in certain regions [8].

Research institutions, such as Chinese Academy of Sciences, Tsinghua University and Huazhong University of Science & Technology, have carried out a series of researches on the migration pattern, chemical reaction as well as solidification mechanism of CO<sub>2</sub> saline storage process, and CO<sub>2</sub> injection technology as well as storage control technology. A few industrial-scale saline aquifer storage pilot demonstrations have been carried out in China.

### 8.1.3 R&D of CO<sub>2</sub> Utilization Technology

In recent years, China has actively promoted research and demonstration on CO<sub>2</sub> utilization, focusing on CO<sub>2</sub> enhanced oil recovery (EOR), enhanced coal bed methane recovery (ECBM), CO<sub>2</sub> bio-fixation and chemical production.

In terms of geological utilization, petroleum enterprises such as PetroChina, Sinopec and Shaanxi Yanchang Petroleum (Group), Co., Ltd have actively carried out research on EOR and CO<sub>2</sub> storage technology and have completed a few EOR demonstration projects. China United Coalbed Methane Corp., Ltd. has carried out an experimental study on the technology for enhanced recovery of coal bed methane by CO<sub>2</sub> injection.

In terms of CO<sub>2</sub> chemical utilization, China's enterprises and research institutions have made progress in various fronts in producing high-value chemicals such as methanol, olefins, aromatics, gasoline, formic acid, synthesis gas from reforming CO<sub>2</sub> and methane, and degradable plastics, and are in the process of industrialization.

In terms of bio-utilization, ENN has successfully developed microalgae bio-fixation technology and built a pilot plant for biodiesel production from microalgae. On this basis, it has built a demonstration project for microalgae carbon bio-fixation energy system from in Daqi. Microalgae are used to absorb CO<sub>2</sub> from flue gas of a coal-to-methanol/dimethyl ether plant to produce biodiesel and by-product feed at the same time.

## **8.2 CCS/CCUS Industrial Demonstration and Application in China**

Under guidance of national policies and with support from government agencies at all levels, China has built over ten CCS demonstration facilities with CO<sub>2</sub> capture capacity of over 10,000 tons for coal-fired power plants and coal chemical plants, of which the maximum CO<sub>2</sub> capture capacity is over 100,000 tons/year (see Table 8-1 for details). Demonstration of CO<sub>2</sub> injection EOR and carbon storage industry has been carried out, with max storage over 150,000 tons/year. The completed demonstration projects include the project of onshore CO<sub>2</sub> storage in saline aquifers with a capacity of 100,000 tons/year, the project of microalgae carbon capture, etc.

[9]

- In July 2007, the first CCS demonstration project was built in the Gaobeidian Thermal Power Plant, with an annual CO<sub>2</sub> capture capacity of 3,000 tons, reaching the purity standard for food. In 2009, Shanghai Shidongkou Thermal Power Station built a second CCS project, with an annual CO<sub>2</sub> capture capacity over 100,000 tons.

- PetroChina Jilin Oilfield CCS-EOR project has captured and stored 1.7 million tons CO<sub>2</sub> during four the years since commissioning, and increased crude oil production of over 700,000 tons.
- In 2017, China built its first large-scale CCS demonstration project in Yulin, Shaanxi Province. The project captures CO<sub>2</sub> from coal chemical plants, then purifies and injects it into oil fields for EOR and storage. It is designed to capture 410,000 tons CO<sub>2</sub> per year.
- The CCS test platform of CR Haifeng Power Plant has completed the main construction and is expected to be commissioned in early 2019. The platform is based on Unit No.1 of CR Haifeng Power Plant and comprised of two test lines for MEDA absorption and membrane separation, while still reserving some sites for other tests. Each year the platform captures 20,000 tons of CO<sub>2</sub>.
- China Energy is building an integrated post-combustion CCS demonstration project with a capacity of 150,000-ton/year, which is expected to complete in 2019. Based on the 600MW subcritical coal-fired unit of Guohua Jinjie Power Plant, the project captures CO<sub>2</sub> using advanced chemical absorption and carries out EOR. It demonstrates the full process, featuring simultaneously-constructed industrial verification facilities for 1000-ton CO<sub>2</sub> capture using chemical adsorption.
- In 2018, Yanchang Petroleum's project for CO<sub>2</sub> EOR technology and geological monitoring was officially launched. Its annual CO<sub>2</sub> storage capacity is estimated to exceed 100,000 tons, and its oil

recovery factor is expected to increase by over 8% on top of conventional water-driven recovery, thereby effectively improving exploitability of ultra-low permeability reservoirs.

The development and implementation of the demonstration projects above have laid the foundation for China to carry out large-scale full-process demonstration in the future. However, the current cost of CCUS is relatively high. The demonstration results show that the introduction of CCS using existing technologies will increase operating cost by 140-600 yuan/ton CO<sub>2</sub>. For example, the cost of electricity in Huaneng Shanghai Shidongkou CCS demonstration project increased from 0.26 yuan/kWh to 0.5 yuan/kWh.

**Table 8-1 Overview of major CCUS pilot demonstration projects in China** <sup>[10]</sup>

	Project Name	Capacity (ton/year)	CCS Source	Technology for Final Storage	Construction/ Operation Status
1	CHNG Shanghai Shidongkou CCS Project	120,000	Shanghai Shidongkou No. 2 Power Plant, Phase II Project, USC Unit	Industrial utilization and food	Commissioning in 2009, intermittent operation
2	CHNG Tianjin Green Coal Power Project	100,000	Tianjin, Binhai New District, 400 MW IGCC unit	Mostly for abandoned land oil and gas reservoirs	Capture facility completed; storage facility delayed
3	Sinopec Shengli Oilfield CO <sub>2</sub> CCS and flooding demonstration	Phase I: 40,000 Phase II: 1 million.	Shengli Power Plant Unit No.5	EOR	Phase 1: Operation in 2010
4	Sinopec Qilu Petrochemical CCS Project	Phase I: 350,000 Phase II: 500,000	Sinopec Qilu Petrochemical Co., Ltd Coal Gasification Plant	EOR	Phase 1: CCS unit completed in 2017
5	Sinopec ZPEB CO <sub>2</sub> -EOR Project	100,000	Zhongyuan Refinery Flue Gas	EOR	CCS facility completed in 2015
6	Yanchang petroleum yulin chemical CCS	50,000	Shaanxi Yanchang Petroleum Yulin Coal Chemical Co., Ltd gasification plant	EOR	Completed in 2012 in operation
7	Shenhua Erdos full process demonstration	100,000	Shenhua Coal-to-Liquid Chemical Co., Ltd.	CO <sub>2</sub> storage in saline aquifers	Commissioning in 2011, intermittent operation
8	PetroChina Jilin Oilfield EOR Demonstration	Phase I: 150,000 Phase II:	New Natural Gas Plant in Songyuan City, Jilin Province	EOR	Phase I: Commissioning in 2007



		500,000			Phase II: Commissioning in 2017, with size reduced
9	CPI Chongqing Shuangyu Power Plant CCS Demonstration Project	10,000	Chongqing Hechuan Shuangyu Power Plant Phase I 1# 300MW unit boiler	Welding protection, hydrogen cooling replacement for generator, etc.	Commissioning in 2010, in operation
10	HUST 35MW oxyfuel combustion project	100,000	Hubei Jiuda (Yingcheng) Co., Ltd. Thermal Power Plant II	industrial application	Completed in 2014, operation suspended
11	Lianyungang Clean Coal Energy Power System Research Facilities	30,000	Lianyungang 400MW IGCC	CO <sub>2</sub> storage in saline aquifers	Commissioning in 2011, in operation
12	Tianjin Beitang Power Plant CCUS Project	20,000	Tianjin Beitang Power Plant	Food application	Commissioning in 2012, in operation
13	Xinjiang Dunhua Oil Co., Ltd Project	60,000	Xinjiang Dunhua Oil, Refinery Exhaust	EOR	Commissioning in 2015, in operation
14	<b>China Energy Guohua Jinjie Power Plant CCS full process demonstration project</b>	150,000	<b>Coal-fired power plant flue gas</b>	<b>Storage/EOR</b>	To be completed in 2019
15	<b>CR Haifeng Project</b>	20,000	<b>Guangdong coal-fired power plant flue gas</b>	<b>CO<sub>2</sub> food grade/ industrial grade</b>	Commissioning in 2019

## 8.3 Typical Industrial Demonstration Projects

### 8.3.1 Huaneng Greengen IGCC Demonstration Project

Huaneng Tianjin Greenen IGCC is the first in China and the sixth in the world IGCC power station that is only for power generation. It was officially commissioned in November 2012, with a total investment of about 3.6 billion yuan and unit cost of 13,000-14,000 yuan/kW (much higher than the unit cost of coal-fired power plants in China).

The project adopts a two-stage dry coal pulverization gasifier developed independently by Xi'an Thermal Engineering Institute (TPRI) with a capacity of 2000 tons/day; an independent air separation system, featuring low pressure, molecular sieve purification and double internal compression; a purification system that uses high temperature ceramics for dust-removal, MDEA for desulfurization, and LO-CAT process for sulfur recovery; an

SGT-2000E gas turbine, with a power of 173MW; and a triple-pressure reheat steam turbine. The installed capacity of this power station is 265MW.



**Figure 8-5 China Huaneng Greengen IGCC Power Station**

Since the project was commissioned, a few key technical indicators have been significantly improved, system reliability risen continuously, and auxiliary power consumption rate, coal consumption rate and pollutant emission significantly decreased. In 2018, the entire facility operated continuously for 3,993 hours (166 days), exceeding the 3,917 hours record of Japan's Nakoso IGCC power station, thereby creating an IGCC world record for continuous operation time. As more experience is gained from operation, its performance continues to improve while its costs of electricity generation keep declining. At present, the net power efficiency of the entire power station has reached 38% (LHV).

The power station achieved the goal of the first phase of “Greengen Plan”. It has built the world's largest IGCC testing system, with an annual CO<sub>2</sub> capture capacity of 100,000 tons. The unit energy consumption of CO<sub>2</sub> capture is less than 2.5GJ/t (CO<sub>2</sub>), making the facility a key R&D base for

IGCC in China. The second phase is to develop key technologies and build a 60,000-100,000 ton/year pre-combustion CO<sub>2</sub> capture facility. The third phase aims to build a 400MW IGCC+CCS demonstration power station.

### 8.3.2 PetroChina Jilin Oilfield CCS-EOR Demonstration Project

With support of the MOST, CNPC launched “Research on Exploitation, Integrated Utilization and Storage of CO<sub>2</sub>-rich Natural Gas Reservoirs in Jilin Oilfield” in 2007. The project separates CO<sub>2</sub> from natural gas by MEA absorption, transports CO<sub>2</sub> through pipeline and injects it into the oil field to improve oil recovery in low permeability oilfields.

In 2006, Jilin Oilfield established 6 injection wells and 23 production wells in No. 59 Black Zone to conduct pilot test of CCS-EOR technology. Compared with the water-driven approach, the test yields an increase in production by 52%, in recovery rate by over 10%, and CO<sub>2</sub> dynamic storage rate of over 96%.

In 2010, No. 79 Black Zone, which is medium-high water-bearing oil reservoir, was selected as the extended test area. 18 new injection well and 64 production wells were added. The annual production of CO<sub>2</sub> EOR surpassed 90,000 tons.

In 2012, further exploration on EOR implementation in flooded reservoirs was made. By the end of 2016, after injecting CO<sub>2</sub> for four consecutive years, average daily oil production in the test area was kept at 35-40 tons, equivalent to 4-5 times production from the water-driven approach, and the recovery rate was 15% higher.

After years of research and practice, Jilin Oilfield has developed the main technology of CO<sub>2</sub> EOR and storage in continental sedimentation low-permeability reservoirs and built 5 types of CCS-EOR demonstration areas, with 3 CO<sub>2</sub> injection stations and 69 injection wells. As a result, the annual CO<sub>2</sub> storage capacity reaches over 350,000 tons; and its *Operation Procedures of Oilfield CO<sub>2</sub> Injection* has become a national standard.

**8.3.3 Shenhua 100,000 ton/year CCS Demonstration Project**  
Shenhua's 100,000 ton/year CCS demonstration project is China's first full-process CCS demonstration project <sup>[11]</sup>. For the first time, it combines CO<sub>2</sub> capture technology of high-concentration CO<sub>2</sub> from coal chemical industry, and CO<sub>2</sub> storage technology for deep saline aquifers.

The demonstration project utilizes CO<sub>2</sub> exhaust discharged from the Ordos coal gasification facilities for hydrogen production. After being captured, purified and liquefied, CO<sub>2</sub> is transported by tank truck to the storage site, and then pressurized, heated and injected in super-critical state into the deep saline aquifers.

In June 2010, Shenhua's 100,000-ton CCS demonstration project started construction and took half a year to complete the construction of CCS liquefaction, storage, loading area and storage area. In January 2011, the test production achieved a success along with continuous injection and monitoring. At present, the project has achieved the goal of a total injection volume of 300,000 tons, an outstanding demonstrative result.

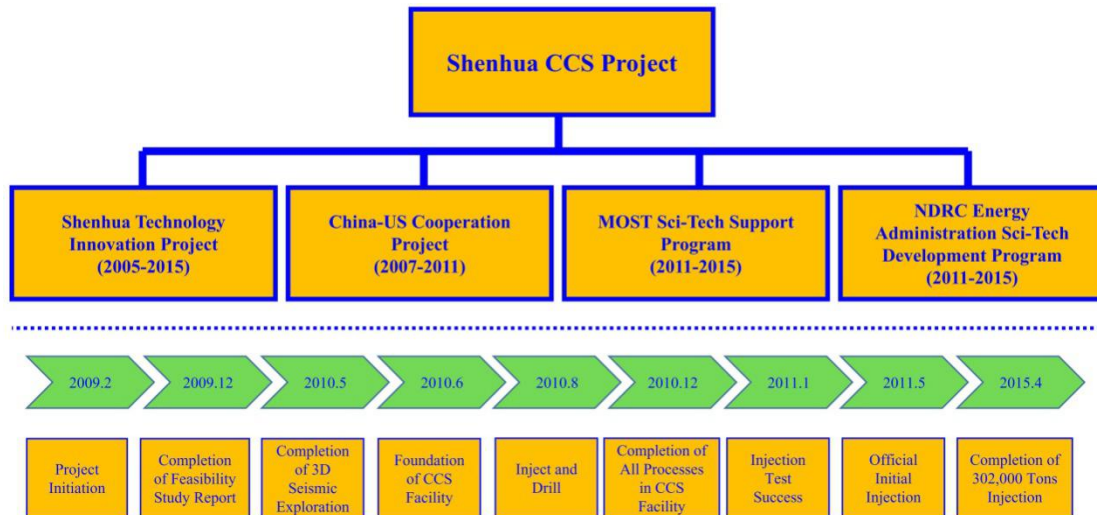

**Figure 8-6 Progress of Shenhua 100,000 tons/year CCS Full Process Demonstration Project**



**Figure 8-7 Outdoor Scene of Shenhua 100,000-ton/year CCS project**

## References

- 
- [1] IPCC. Climate Change 2014: Synthesis Report. Contribution of Working Groups I, II & III to the Fifth Assessment Report of the Intergovernmental Panel on Climate Change. 2014
  - [2] IEA. Energy Technology Perspectives 2017. 2017
  - [3] NDRC. National Plan for Tackling Climate Change 2014-2020. 2014
  - [4] National Development and Reform Commission (NDRC). The National Strategy for Climate Change Adaptation. 2013

- [5] National Development and Reform Commission (NDRC). The Work Plan for Controlling Greenhouse Gas Emissions during the 13th Five-Year Plan Period. 2016
- [6] IEA. Energy Technology Perspectives 2012. 2012
- [7] Huazhong University of Science and Technology.  
<http://combustion.energy.hust.edu.cn/kyfx/fyrsytbj.htm>
- [8] Ministry of Science and Technology of the People's Republic of China. Carbon Capture, Utilization and Storage Technology Development in China. 2011
- [9] Ni Linggong, Jiang Dalin, etc. A Study on the Path to Global Commercialization of CCS Technology. China Coal Industry Publishing House. 2016
- [10] Briefing of Research on Climate Change Strategy. 2017, No.24
- [11] Wu Xiuzhang. Carbon Dioxide Capture and Geological Storage: The First Massive Exploration in China. China Science Press. 2013

## **Chapter IX Significance and Demand of Developing CCT in the APEC Region**

As one of the most economically active regions in the world, the APEC region has strong growing demand for energy and power. In terms of the economics and endowment of energy resources, coal-fired power remains an important means to ensure safe, stable and economical power supply for the APEC region. In the future, there is certain technical demand and development space for coal-fired power technologies in the APEC region, especially in Southeast Asia.

### **9.1 The Ever-growing Power Demand in the APEC Region**

#### **9.1.1 Rapid Growth of Primary Energy Demand**

From 1990 to 2016, primary energy consumption increased rapidly in the APEC region resulted from the rapid economic growth, with an average annual growth rate of about 3.3%, higher than that of the global, 3%. Coal, oil and natural gas are the dominant primary energy in the APEC region, accounting for 35.4%, 29.5% and 21.7% in primary energy consumption in 2016 respectively. The proportion of coal consumption in the APEC region is significantly higher than the global average. Coal consumption in the APEC region is still huge, though it has generally declined since 2011 (see Figure 9-1).

Developed APEC economies, such as the United States, Japan, Canada and Singapore, are experiencing moderate growth after economic surge. Developing and emerging APEC economies, such as China, Indonesia, the

Philippines and Viet Nam, are experiencing medium-high growth. The GDP of these economies will continue to maintain annual growth of about 5% in the next five years according to IMF's forecast. Therefore, the future energy demand in such economies will keep soaring.

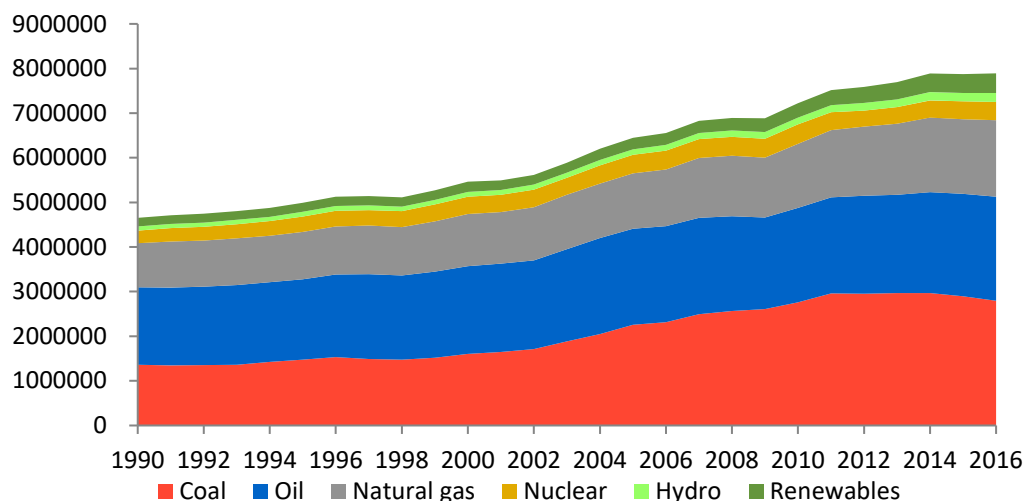

**Figure 9-1 Primary Energy Consumption in APEC Economies (1990-2016)**

Source: APEC Energy Database

### 9.1.2 Rapid Growth of Power Demand

The APEC region contains several economies with huge power consumption and growing demand. Both power consumption and its growth in the APEC region account for more than half of those in the world. In the past two decades, power consumption growth in the APEC region has remained fast with an average annual growth of about 3%, except for the year 2008 and 2009 when the power consumption was weakened by the economic crisis. New power demand mainly comes from China; Republic of Korea; Indonesia; Chinese Taipei; Mexico; and Viet Nam (see Figure 9-2).



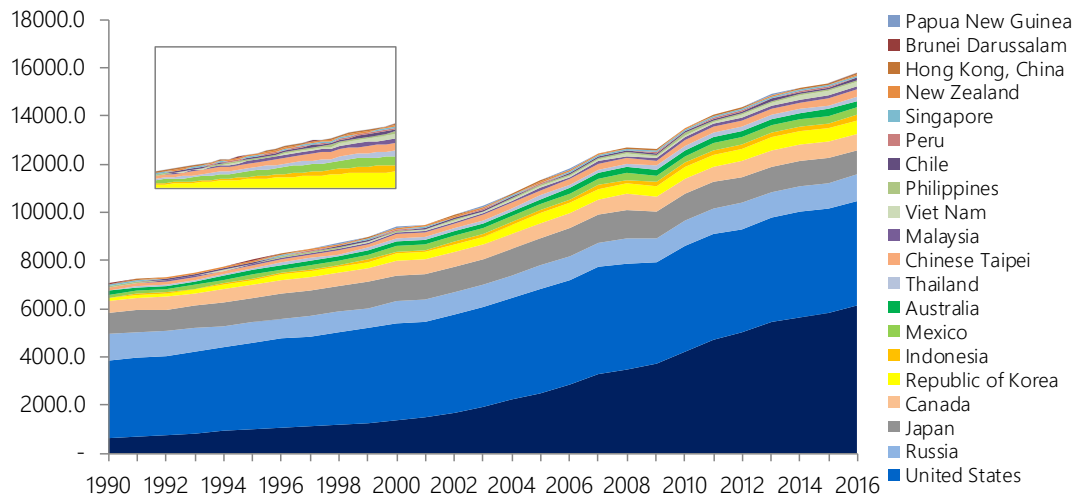

**Figure 9-2 Power Consumption in APEC Economies (1990-2016)**

Source: APEC Energy Database, BP

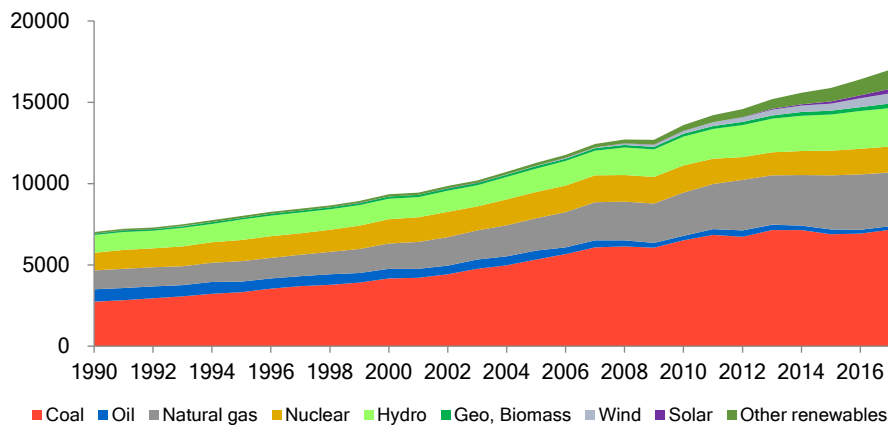

**Figure 9-3 Power Consumption by Fuel in APEC Economies (1990-2016)**

Source: BP Statistical Review of World Energy 2018

Coal-fired power, gas power and hydropower are the dominant power technologies in the APEC region, accounting for 42.1%, 19.4% and 13.9% of power consumption in 2017 respectively. In recent years, coal-fired power has grown steadily, renewable power has increased rapidly and oil power has decreased gradually, as shown in Figure 9-2 and 9-3.

The dominant power is coal-fired power in Australia; China; Hong Kong,

China; Indonesia; Republic of Korea; The Philippines and Chinese Taipei; gas power in Brunei Darussalam; Mexico; Russia; Singapore; and Thailand; hydropower in Canada and New Zealand; oil power in Papua New Guinea; coal-fired power and gas power in Japan, Malaysia and the United States with equal importance; coal-fired power and hydropower in Chile<sup>2</sup> and Viet Nam with equal weight; and gas power and hydropower in Peru with equal emphasis, as shown in Figure 9-4.

Coal-fired power consumption accounted for more than 15% of power consumption in 14 APEC economies in 2016, including China (69.2%); Hong Kong, China (63.7%); Australia (63.6%); Indonesia (54.6%); The Philippines (47.7%); Chinese Taipei (44.3%); Malaysia (44.1%); Republic of Korea (42.1%); Chile (38.1%); Viet Nam (37.8%); Japan (33.2%); the United States (31.5%); Thailand (19.8%); and Russia (15.7 %).

In two economies, the ratio of coal-fired power consumption is between 3% and 15%: Mexico (10.8%) and Canada (9.3%).

For five economies, the ratio is very low, or close to zero, including Peru; Singapore; New Zealand; Brunei Darussalam; and Papua New Guinea.

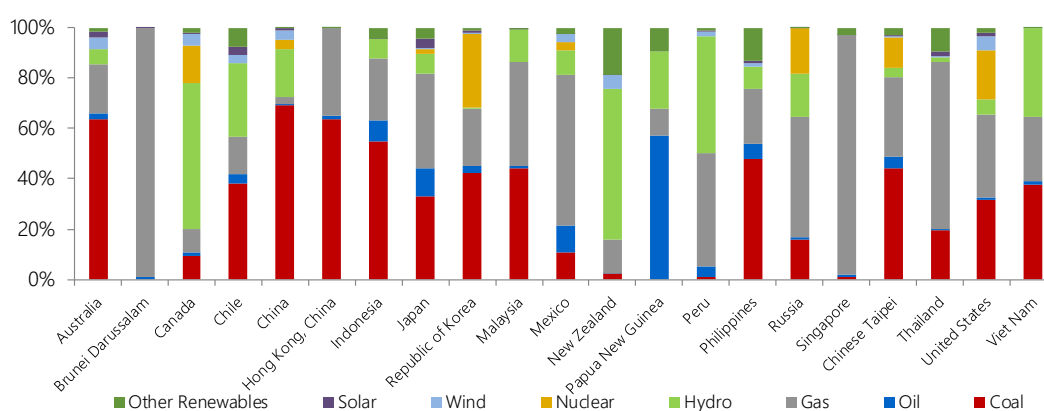

**Figure 9-4 The Ratio of Power Consumption by Fuel in APEC Economies (2016)**

<sup>2</sup> In June 2019, Chile announced the phase-out of its coal-fired power plants by the year 2040.

## **9.2 Significance and Challenges of Developing CCT in the APEC region**

### **9.2.1 CCT Can Ensure Sufficient Supply of Electricity**

Governments of the 21 APEC economies have all proposed energy policies for developing clean energy (such as renewable) and increasing the proportion of renewable power generation. Clean electricity is in rapid development.

However, energy resource endowments of the 21 economies vary greatly. Among the above 14 APEC economies relying on coal-fired power, Japan, Republic of Korea, the Philippines and Malaysia mostly rely on imported coal; the rest domestic. The APEC region is rich in coal, making its price cheap, its supply stable and reliable. Coal-fired power may play a key role in ensuring a stable and safe supply of electricity in these economies.

### **9.2.2 CCT Has Cost Advantages**

In recent years, the renewable power technology has witnessed rapid development worldwide; equipment and power generation costs have been significantly reduced. However, the cost is still high in the APEC region, compared with coal-fired power, as shown in Figure 9-5.

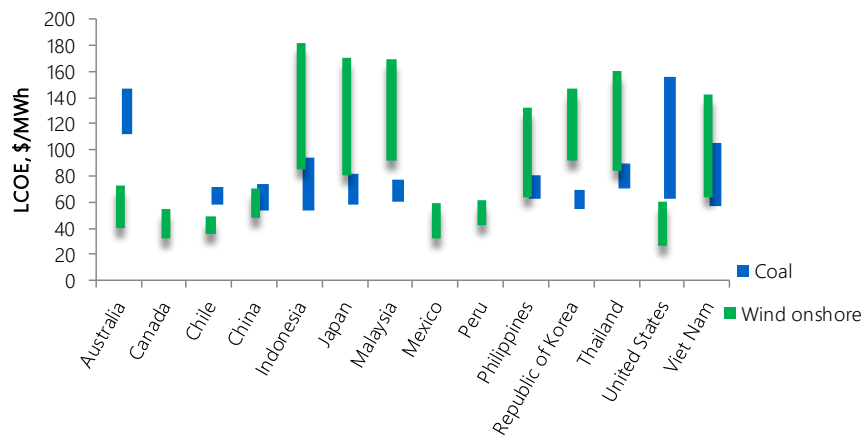

**Figure 9-5 Cost Comparison between Coal-fired Power and Wind Power in APEC Economies**

Source: Bloomberg Database

In recent years, due to high prices of natural gas in the global market, gas power costs are much higher than those of coal-fired power in most APEC economies, except for the United States where the gas power cost is lower than that of coal-fired power because of its large amount of cheap shale gas. Coal-fired power is the top choice for developing APEC economies due to its low cost.

### 9.2.3 CCT Can Meet Environmental Protection Requirements

Coal-fired power will still account for a considerable proportion of the power supply in the APEC region for quite a long time. Developing economies such as Indonesia, Malaysia, the Philippines, Thailand and Viet Nam especially will mostly depend on coal-fired power to meet their increased demand for electricity in the future.

Conventional pollutants emissions of coal-fired power can meet the emission limits of gas power, applying particular, NO<sub>x</sub>, SO<sub>2</sub> control technologies and ultra-low emissions technologies, as shown in previous

chapters. This will in fact solve regional pollution problems and reduce environmental protection pressure. The CFB power technology can burn slime, coal gangue, garbage, etc. to generate electricity, improving people's living environment by turning wastes into resources. The SC/USC coal-fired power technology and CHP technology can greatly improve energy efficiency and significantly reduce CO<sub>2</sub> emissions. Operation feedbacks from European and American economies show that coal-fired power technologies coupled with biomass can further reduce CO<sub>2</sub> emissions. As CCS/CCUS technologies progress, large-scale CCUS technologies are expected to become more economically efficient. The combination of clean and efficient coal-fired power generation and CCS/CCUS technologies will fundamentally solve the greenhouse gas emissions problems in coal-fired power.

## 9.3 Analysis on Future Demand for CCT

### 9.3.1 Demand Forecast of CCT

Many international research institutes have made forecast on the power development in APEC region. Table 9-1 shows the forecasted demands for coal-fired power in 16 APEC economies in 2030, conducted by the APERC, IEA and the CCT Center of APSEC recently.

The CCT Center of APSEC made prediction on the total power generation of each APEC economy in 2030, by working together with Tsinghua University. The method is listed as below:

$$\text{power generation} = \text{population} \times \frac{\text{GDP}}{\text{population}} \times \frac{\text{power generation}}{\text{GDP}} = \text{population} \times \text{per capita GDP} \times \text{per unit GDP power consumption}$$

The actual data of the economies in the APEC database is regarded as the basis. 2016 is taken as the base year; the average annual growth rate of power generation from 2011 to 2016 is taken as the base. Assuming a rapid growth rate from 2017 to 2020 and a relatively slow growth rate from 2021 to 2030, we can get the annual growth rate of power generation of each APEC economy from 2017 to 2030 and further predict the power generation in 2030.

In BAU scenario, an analysis is made on power mix of APEC economies from 2011 to 2016, annual change in proportions of coal-fired power and renewable power generation are produced by linear regression; then assuming 2016 as the base year with increasing development of renewable power, the proportion of coal-fired power in the power mix is projected for each economy in 2030. In the low-carbon scenario, coal-fired power generation accounts for 20% less than that in the BAU scenario. The data is shown in Table 9-1, 9-2.

**Table 9-1 Forecast of Coal-fired Power Generation of APEC Economies in 2030 (Unit: TWh)**

APEC economies	APEC database	APERC		IEA		CCT Center, APSEC	
	2016	2030 BAU scenario	2030 other scenarios*	2030 new policies scenario	2030 other scenarios**	2030 BAU scenario	2030 low carbon scenario
Australia	163	136	72-136			143	114
Canada	62	30	23-30			46	37
Chile	30	60	23-60			14.8	11.9
China	4249	6282	4513~6282	4232	2267~5333	5441	4353
Hong Kong, China	24	20	20			9	7
Indonesia	135	276	149~276			289	231
Japan	353	352	289~352	270	75~351	377	302
Republic of Korea	235	272	205~272			229	183
Malaysia	69	117	75~117			118	94
Mexico	35	32	32			37	29
The Philippines	43	96	68~96			94	75
Russia	171	164	89~164	141	57~181	176	141
Chinese Taipei	117	155	119~155			86	69
Thailand	37	70	28~70			64	51
The United States	1354	1205	769~1205	1272	151~1373	1061	849
Viet Nam	68	156	58~156			262	210
Total	7150	9424	6997~9424	9880	4472~12039	8487	6790

Source: APEC. APEC Energy database. <https://www.egeda.ewg.apec.org/>

APERC. APEC Energy Demand and Supply Outlook, 6th edition.

IEA. World Energy Outlook 2017.

\* APERC other scenarios: improved efficiency scenario, high renewables scenario and alternative Power mix scenario.

\*\* IEA other scenarios: Current policies scenario and sustainable development scenario.

**Table 9-2 Forecast of Coal-fired Power Capacity of APEC Economies in 2030 (Unit: GW)**

APEC economies	Bloomberg NEF	APERC		IEA		CCT Center, APSEC	
	2016	2030 BAU scenario	2030 other scenarios*	2030 new policies scenario	2030 other scenarios**	2030 BAU scenario	2030 low carbon scenario
Australia	27	25	20-25			24	19
Canada	9	5	5			7	5
Chile	5	10	4~10			2.3	1.9
China	967	1342	952~1342	1089	846~1218	1240	992
Hong Kong, China	7	11	11			2	2
Indonesia	30	61	32~61			64	51
Japan	46	46	39~46	48	32~53	49	39
Republic of Korea	33	39	29~39			32	26
Malaysia	10	17	11~17			16	13
Mexico	5	5	5			6	5
The Philippines	7	17	7~17			16	13
Russia	40	47	25~47	30	22~34	41	33
Chinese Taipei	17	22	17~22			12	9
Thailand	5	11	4~11			8	6
The United States	256	211	205~211	227	137~230	201	161
Viet Nam	15	29	12~29			56	45
Total	1478	1898	1384~1898	2296	1686~2534	1782	1426

Source: Bloomberg NEF. <https://about.bnef.com>

APERC. APEC Energy Demand and Supply Outlook, 6th edition.

IEA. World Energy Outlook 2017.

\* APERC other scenarios: improved efficiency scenario, high renewables scenario and alternative Power mix scenario.

\*\* IEA other scenarios: current policies scenario and sustainable development scenario.



The three institutions have made basically the same prediction for overall development trend of coal-fired power in the APEC region. In general, the 16 economies where coal-fired power accounts for a certain proportion in their power mix have the following development trend:

(1) China and some Southeast Asian economies including Indonesia, Malaysia, the Philippines, Thailand and Viet Nam are expected to see fast growth in coal-fired power capacity and generation. They are projected to be key economies for coal-fired power development in the APEC region.

(2) Russia, Japan, Republic of Korea and Mexico will not see too much change in coal-fired power capacity and generation; they will still keep a certain number of coal-fired power units by 2030.

(3) Australia, Canada, Chile and the United States will decrease the proportion of coal-fired power in their power mix, because of their focus on low-carbon development. But by 2030, the United States will still have about 200 GW coal-fired power units, and Australia above 20 GW.

(4) Hong Kong, China and Chinese Taipei will see a decline in both capacity and generation of coal-fired power in the future.

It can be seen from the predictions of the three institutions that there is still a large demand for coal-fired power in the APEC region in the future, but not every economy is the same.

### 9.3.2 Analysis and Suggestions on Future Demand for CCT

Studies show that, there are two categories of demand for CCT in APEC economies:

One demand is for newly-built power units. Based on power and heat

demand from users and local environmental protection standards, these economies could choose from combined technologies such as “SC/USC coal-fired power unit+ pollutant control”, “CHP unit+ pollutant control” or “CFB unit + pollutant control”. Areas with rich biomass resources can also consider technology combinations such as “SC/USC coal-biomass power unit + pollutant control”, “CHP coal-biomass unit + pollutant control” or “CFB coal-waste unit + pollutant control”. The future trend of coal-fired power technology will move towards integration, namely USC coal-fired power + CHP + biomass coupled combustion + pollutant control + CCS or IGCC + CCS/CCUS.

The other demand is on active coal-fired power units. APEC economies could retrofit existing units, according to local government policy or environmental protection requirements, by choosing appropriate CHP technology + pollutant control, energy-saving retrofit or ultra-low emission and environmental protection retrofit, etc. The overall goal is to improve efficiency and reduce pollution.

CCT is still attractive in the APEC region, because it can meet the needs of the economies (especially Southeast Asian ones) in developing efficient, economical and green power. It is up to each economy to choose suitable CCT to meet its own power needs, according to its unique conditions and demand.

## References

---

- [1] APEC. APEC Energy database. <https://www.egeda.ewg.apec.org/>

- [2] APERC. APEC Energy Demand and Supply Outlook, 6th edition. 2016
- [3] Bloomberg. Bloomberg NEF. <https://about.bnef.com>
- [4] BP. BP Statistical Review of World Energy 2018. 2018
- [5] IEA. World Energy Outlook 2017. 2017
- [6] Environment Bureau of Hong Kong, China. Hong Kong climate action blueprint 2030+. 2017
- [7] IMF. World Economic Outlook Database, October 2018. 2018
- [8] IEA. IEA Electricity Information 2018. 2018
- [9] METI. Strategic Energy Plan, April 2014. 2014
- [10] The Ministry of Trade, Industry and Energy. The 8th Basic Plan for Long-term Electricity Supply and Demand. 2017
- [11] Economic Planning Unit, Prime Minister's Department, Malaysia. Eleventh Malaysia Plan, 2016-2020. 2015
- [12] Taiwan's Legislature. Amendments to Electrical Industry Law. 2017
- [13] Energy Policy and Planning Office, Ministry of Energy, Thailand. Thailand Power Development Plan 2015-2036. 2015
- [14] Ministry of Industry and Trade (MOIT), and Danish Energy Agency. Vietnam Energy Outlook Report 2017. 2017

## Annex I Abbreviation and Acronyms

APEC	Asia-Pacific Economic Cooperation
APERC	Asia Pacific Energy Research Centre
APS	Automatic Power Plant Startup and Shutdown System
APSEC	APEC Sustainable Energy Center
BAU	Business As Usual
BMCR	Boiler Maximum Continuous Rating
BOO	Building-Ownning-Operation
CCS	Carbon Capture and Storage
CCT	Clean Coal Technology
CCTDP	Clean Coal Technology Demonstration Program
CCUS	Carbon Capture, Utilization and Storage
CFB	Circulating Fluidized Bed
CO <sub>2</sub>	Carbon dioxide
CO <sub>2</sub> -ECBM	CO <sub>2</sub> enhanced coal bed methane
EAF	Equivalent Availability Factor
EOR, CO <sub>2</sub> -EOR	CO <sub>2</sub> Enhanced Oil Recovery
EPC	Engineering Procurement Construction
FCB	Fast Cut Back
GDP	Gross Domestic Product
GRCF	Generating Reliability Comprehensive factor
IEA	International Energy Agency
IGCC	Integrated Gasification Combined Cycle
IPCC	Intergovernmental Panel on Climate Change
IPP	Independent Power Producer
MEA	Membrane Electrode Assembly
NO <sub>x</sub>	Nitrogen oxides
PM <sub>2.5</sub>	particulate matter of size up to 2.5µm
PPA	Power Purchase Agreement
R&D	Research and Development
SCR	Selective Catalytic Reduction
SNCR	Selective Non-Catalytic Reduction
SO <sub>2</sub>	Sulfur dioxide
SO <sub>3</sub>	Sulfur trioxide
THA	Turbine Heat-rate Acceptance power

## Annex II Units

g/kWh	grams per kilowatt-hour
gce/kWh	grams of coal equivalent per kilowatt-hour
kW	kilowatt (1 watt $\times 10^3$ )
MW	megawatt (1 watt $\times 10^6$ )
GW	gigawatt (1 watt $\times 10^9$ )
GWh	gigawatt-hour
TWh	terawatt-hour
kcal/kg	kilocalorie per kilogram
kg/GJ	kilogram per gigajoule
kJ/kWh	kilojoule per kilowatt-hour
kPa	kilopascal
ktoe	thousand tons of oil equivalent
Mtoe	million tons of oil equivalent
m <sup>2</sup>	square meter
m <sup>3</sup>	cubic meter
mg/m <sup>3</sup>	milligram per cubic meter
mg/Nm <sup>3</sup>	milligram per normal cubic meter
MJ/kg	megajoule per kilogram
Pa	pascal
MPa	megapascal
t/a	tons per year
t/h	tons per hour